



CAGE Code 81205

747-400 Airplane Characteristics for Airport Planning

DOCUMENT NUMBER:

D6-58326-1

REVISION:

REV E

REVISION DATE:

September 2023

CONTENT OWNER:

Boeing Commercial Airplanes

All revisions to this document must be approved by the content owner before release.

Not Subject to US Export Administration Regulations (EAR), (15 C.F.R. Parts 730-774) or US International Traffic in Arms Regulations (ITAR), (22 C.F.R. Parts 120-130).



Revision Record

Revision Letter	A
Revision Date	April 1988
Changes in This Revision	Pages 1 to 122
<hr/>	
Revision Letter	B
Revision Date	March 1990
Changes in This Revision	Pages 1 to 156
<hr/>	
Revision Letter	C
Revision Date	October 1994
Changes in This Revision	Pages 1 to 164
<hr/>	
Revision Letter	D
Revision Date	December 2002
Changes in This Revision	Pages 1 to 218
<hr/>	
Revision Letter	E
Revision Date	September 2023
Changes in This Revision	Section 6: Add Inlet Hazard Area information. Section 7: Add ACR information.

Table of Contents

1.0	SCOPE AND INTRODUCTION	1-1
1.1	SCOPE	1-1
1.2	INTRODUCTION	1-2
1.3	A BRIEF DESCRIPTION OF THE 747-400.....	1-3
2.0	AIRPLANE DESCRIPTION.....	2-1
2.1	GENERAL CHARACTERISTICS	2-1
2.1.1	General Characteristics: Model 747-400 (General Electric Engines)	2-2
2.1.2	General Characteristics: Model 747-400 (Pratt & Whitney Engines).....	2-3
2.1.3	General Characteristics: Model 747-400 (Rolls-Royce Engines).....	2-4
2.1.4	General Characteristics: Model 747-400 Combi (General Electric Engines).....	2-5
2.1.5	General Characteristics: Model 747-400 Combi (Pratt & Whitney Engines).....	2-6
2.1.6	General Characteristics: Model 747-400 Combi (Rolls-Royce Engines).....	2-7
2.1.7	General Characteristics: Model 747-400 Freighter (General Electric Engines)	2-8
2.1.8	General Characteristics: Model 747-400 Freighter (Pratt & Whitney Engines).....	2-9
2.1.9	General Characteristics: Model 747-400 Freighter (Rolls Royce Engines).....	2-10
2.1.10	General Characteristics: Model 747-400ER	2-11
2.1.11	General Characteristics: Model 747-400ER Freighter.....	2-12
2.1.12	General Characteristics: Model 747-400 Domestic (General Electric Engines)	2-13
2.2	GENERAL DIMENSIONS	2-14
2.2.1	General Dimensions: Model 747-400, -400 Combi, -400ER	2-14
2.2.2	General Dimensions: Model 747-400 Freighter, -400ER Freighter	2-15
2.2.3	General Dimensions: Model 747-400 Domestic.....	2-16
2.3	GROUND CLEARANCES	2-17
2.3.1	Ground Clearances: Model 747-400, -400 Combi.....	2-17
2.3.2	Ground Clearances: Model 747-400ER.....	2-18
2.3.3	Ground Clearances: Model 747-400 Freighter	2-19
2.3.4	Ground Clearances: Model 747-400ER Freighter	2-20
2.3.5	Ground Clearances: Model 747-400 Domestic.....	2-21
2.4	INTERIOR ARRANGEMENTS.....	2-22
2.4.1	Typical Interior Arrangements: Model 747-400, Tri-Class Configuration	2-22

2.4.2	Typical Interior Arrangements: Model 747-400ER, Tri-Class Configuration	2-23
2.4.3	Typical Interior Arrangements: Model 747-400ER, Dual Class Configuration	2-24
2.4.4	Typical Interior Arrangements: Model 747-400 Combi, Passenger/Cargo Configuration	2-25
2.4.5	Typical Interior Arrangements: Model 747-400 Freighter, -400ER Freighter, Main Deck Cargo	2-26
2.4.6	Typical Interior Arrangements: Model 747-400 Domestic, High-Density Seating Configuration.....	2-27
2.5	CABIN CROSS SECTIONS	2-28
2.5.1	Cabin Cross-Sections: Model 747-400, First and Business Class Seats	2-28
2.5.2	Cabin Cross-Sections: Model 747-400, Business Class Seats	2-29
2.5.3	Cabin Cross-Sections: Model 747-400, Economy Class Seats	2-30
2.5.4	Cabin Cross-Sections: Model 747-400, Galley and Stairs.....	2-31
2.6	LOWER CARGO COMPARTMENTS	2-32
2.6.1	Lower Cargo Compartments: Model 747-400, -400 Combi, -400 Domestic, Containers and Bulk Cargo.....	2-32
2.6.2	Lower Cargo Compartments: Model 747-400ER, Containers and Bulk Cargo	2-33
2.6.3	Lower Cargo Compartments: Model 747-400 Freighter, -400ER Freighter, Containers and Bulk Cargo	2-34
2.7	DOOR CLEARANCES.....	2-35
2.7.1	Door Locations: Model 747-400, Main Deck Passenger and Cargo Doors	2-35
2.7.2	Door Clearances: Model 747-400, Main Deck Entry and Service Doors 1-4 (Plan View)	2-36
2.7.3	Door Clearances: Model 747-400, Main Deck Entry and Service Doors 1-4 (View Looking Forward)	2-37
2.7.4	Door Clearances: Model 747-400, Main Deck Entry and Service Door 5.....	2-38
2.7.5	Door Clearances: Model 747-400, Upper Deck Emergency Exit Door.....	2-39
2.7.6	Door Clearances: Model 747-400, Lower Deck Cargo Door (Forward).....	2-40
2.7.7	Door Clearances: Model 747-400, Lower Deck Cargo Door (Aft)	2-41
2.7.8	Door Clearances: Model 747-400, Bulk Cargo Door	2-42
2.7.9	Door Clearances: Model 747-400 Combi, -400 Freighter, -400ER Freighter, Main Deck Cargo Door	2-43
2.7.10	Door Clearances: Model 747-400 Freighter, -400ER Freighter, Nose Cargo Door.....	2-44

3.0	AIRPLANE PERFORMANCE	3-1
3.1	GENERAL INFORMATION.....	3-1
3.2	PAYLOAD/RANGE	3-2
3.2.1	Payload/Range: Model 747-400, -400 Combi, 0.85 Mach Cruise (CF6-80C2B1F Engines)	3-2
3.2.2	Payload/Range: Model 747-400, -400 Combi, 0.85 Mach Cruise (PW 4056 Engines)	3-3
3.2.3	Payload/Range: Model 747-400, -400 Combi, 0.85 Mach Cruise (RB211-524G Engines).....	3-4
3.2.4	Payload/Range: Model 747-400, -400 Combi, 0.85 Mach Cruise (CF6-80C2B1F Engines)	3-5
3.2.5	Payload/Range: Model 747-400ER, 0.85 Mach Cruise (CF6- 80C2B5F Engines).....	3-6
3.2.6	Payload/Range: Model 747-400ER, 0.85 Mach Cruise (PW 4062 Engines).....	3-7
3.2.7	Payload/Range: Model 747-400ER, 0.85 Mach Cruise (RB211-524H8-T).....	3-8
3.2.8	Payload/Range: Model 747-400ER Freighter, 0.85 Mach Cruise (CF6-80C2B5F Engines)	3-9
3.2.9	Payload/Range: Model 747-400ER Freighter, 0.85 Mach Cruise (PW 4062 Engines)	3-10
3.2.10	Payload/Range: Model 747-400ER Freighter, 0.85 Mach Cruise (RB211-524H8-T Engines).....	3-11
3.2.11	Payload/Range: Model 747-400 Domestic, 0.85 Mach Cruise (CF6-80C2B1F Engines)	3-12
3.3	F.A.R. TAKEOFF RUNWAY LENGTH REQUIREMENTS.....	3-13
3.3.1	F.A.R. Takeoff Runway Length Requirements - Standard Day: Model 747-400 (CF6-80C2B1 Engines).....	3-13
3.3.2	F.A.R. Takeoff Runway Length Requirements - Standard Day + 31°F (STD + 17.2°C): Model 747-400 (CF6-80C2B1 Engines)	3-14
3.3.3	F.A.R. Takeoff Runway Length Requirements - Standard Day: Model 747-400 (PW-4056 Engines)	3-15
3.3.4	F.A.R. Takeoff Runway Length Requirements - Standard Day + 33°F (STD + 18.3°C): Model 747-400 (PW4056 Engines).....	3-16
3.3.5	F.A.R. Takeoff Runway Length Requirements - Standard Day: Model 747-400 (RB211-524G2 Engines).....	3-17
3.3.6	F.A.R. Takeoff Runway Length Requirements - Standard Day + 27°F (STD + 15°C): Model 747-400 (RB211-524G2 Engines)	3-18
3.3.7	F.A.R. Takeoff Runway Length Requirements - Standard Day: Model 747-400 Freighter (CF6-80C2B1 Engines)	3-19
3.3.8	F.A.R. Takeoff Runway Length Requirements - Standard Day + 31°F (STD + 17.2°C): Model 747-400 Freighter (CF6-80C2B1 Engines).....	3-20

3.3.9	F.A.R. Takeoff Runway Length Requirements - Standard Day: Model 747-400ER (CF6-80C2B5F Engines).....	3-21
3.3.10	F.A.R. Takeoff Runway Length Requirements - Standard Day + 31°F (STD + 17.2°C): Model 747-400ER (CF6-80C2B5F Engines)	3-22
3.3.11	F.A.R. Takeoff Runway Length Requirements - Standard Day: Model 747-400ER (PW-4062 Engines).....	3-23
3.3.12	F.A.R. Takeoff Runway Length Requirements - Standard Day + 31°F (STD + 17°C): Model 747-400ER (PW4062 Engines).....	3-24
3.3.13	F.A.R. Takeoff Runway Length Requirements - Standard Day: Model 747-400ER (RB211-524H8-T Engines).....	3-25
3.3.14	F.A.R. Takeoff Runway Length Requirements - Standard Day + 31°F (STD + 17°C): Model 747-400ER (RB211-524H8-T Engines).....	3-26
3.3.15	F.A.R. Takeoff Runway Length Requirements - Standard Day: Model 747-400ER Freighter (CF6-80C2B5F Engines).....	3-27
3.3.16	F.A.R. Takeoff Runway Length Requirements - Standard Day + 31°F (STD + 17°C): Model 747-400ER Freighter (CF6-80C2B5F Engines).....	3-28
3.3.17	F.A.R. Takeoff Runway Length Requirements - Standard Day: Model 747-400ER Freighter (PW4062 Engines).....	3-29
3.3.18	F.A.R. Takeoff Runway Length Requirements - Standard Day + 31°F (STD + 17°C): Model 747-400ER Freighter (PW4062 Engines).....	3-30
3.3.19	F.A.R. Takeoff Runway Length Requirements - Standard Day: Model 747-400ER Freighter (RB211-524H8-T Engines)	3-31
3.3.20	F.A.R. Takeoff Runway Length Requirements - Standard Day + 31°F (STD + 17°C): Model 747-400ER Freighter (RB211-524H8- T Engines)	3-32
3.3.21	F.A.R. Takeoff Runway Length Requirements - Standard Day: Model 747-400 Domestic (CF6-80C2B1 Engines).....	3-33
3.3.22	F.A.R. Takeoff Runway Length Requirements - Standard Day + 31°F (STD + 17.2°C): Model 747-400 Domestic (RB211-524H8- T Engines)	3-34
3.4	F.A.R. LANDING RUNWAY LENGTH REQUIREMENTS	3-35
3.4.1	F.A.R. Landing Runway Length Requirements - Flaps 25: Model 747-400, -400 Combi, -400 Domestic, -400 Freighter.....	3-35
3.4.2	F.A.R. Landing Runway Length Requirements - Flaps 30: Model 747-400, -400 Combi, -400 Domestic, -400 Freighter.....	3-36
3.4.3	F.A.R. Landing Runway Length Requirements - Flaps 25: Model 747-400ER, -400ER Freighter	3-37
3.4.4	F.A.R. Landing Runway Length Requirements - Flaps 30: Model 747-400ER, -400ER Freighter	3-38

4.0	AIRPLANE PERFORMANCE	4-1
4.1	GENERAL INFORMATION.....	4-1
4.1.1	General Information – Body Gear Steering System: Model 747	4-3
4.2	TURNING RADII	4-4
4.2.1	Turning Radii – With Body Gear Steering - Symmetrical Thrust: Model 747	4-4
4.2.2	Turning Radii – Body Gear Steering Inoperative - Symmetrical Thrust: Model 747.....	4-5
4.2.3	Turning Radii – With Body Gear Steering - Unsymmetrical Thrust: Model 747	4-6
4.2.4	Turning Radii – Body Gear Steering Inoperative - Symmetrical Thrust: Model 747.....	4-7
4.2.5	Turning Radii – Towed: Model 747.....	4-8
4.3	CLEARANCE RADII	4-9
4.3.1	Clearance Radii – English Units: Model 747-400, -400 Combi, - 400 Freighter, -400ER, -400ER Freighter.....	4-9
4.3.2	Clearance Radii – Metric Units: Model 747-400, -400 Combi, -400 Freighter, -400ER, -400ER Freighter.....	4-10
4.3.3	Clearance Radii – English Units: Model 747-400 Domestic	4-11
4.3.4	Clearance Radii – Metric Units: Model 747-400 Domestic.....	4-12
4.4	VISIBILITY FROM COCKPIT IN STATIC POSITION: MODEL 747- 400	4-13
4.5	RUNWAY AND TAXIWAY TURN PATHS.....	4-14
4.5.1	Runway and Taxiway Turnpaths - Runway-to-Taxiway, 90 Degrees: Model 747-400.....	4-14
4.5.2	Runway and Taxiway Turnpaths - Runway-to-Taxiway, More Than 90 Degrees, Nose Gear Tracks Centerline: Model 747-400	4-15
4.5.3	Runway and Taxiway Turnpaths - Runway-to-Taxiway, More Than 90 Degrees, Judgmental Oversteering: Model 747-400.....	4-16
4.5.4	Runway and Taxiway Turnpaths - Taxiway-to-Taxiway, 90 Degrees: Model 747-400.....	4-17
4.5.5	Runway and Taxiway Turnpaths - Taxiway-to-Taxiway, 90 Degrees, ICAO Recommendation: Model 747-400.....	4-18
4.6	RUNWAY HOLDING BAY: MODEL 747-400.....	4-19
5.0	TERMINAL SERVICING	5-1
5.1	AIRPLANE SERVICING ARRANGEMENT - TYPICAL TURNAROUND	5-2
5.1.1	Airplane Servicing Arrangement - Typical Turnaround: Model 747-400, -400 Domestic, -400ER	5-2
5.1.2	Airplane Servicing Arrangement - Typical Turnaround: Model 747-400 Combi.....	5-3

5.1.3	Airplane Servicing Arrangement - Typical Turnaround: Model 747-400 Freighter, -400ER Freighter.....	5-4
5.2	TERMINAL OPERATIONS - TURNAROUND STATION	5-5
5.2.1	Terminal Operations - Turnaround Station – All Passenger: Model 747-400, -400 Combi, -400 Domestic.....	5-5
5.2.2	Terminal Operations - Turnaround Station – All Passenger: Model 747-400ER	5-6
5.2.3	Terminal Operations - Turnaround Station – Passenger/Cargo: Model 747-400 Combi	5-7
5.2.4	Terminal Operations – Turnaround Station – All Cargo, Nose Door Loading: Model 747-400 Freighter, -400ER Freighter	5-8
5.2.5	Terminal Operations – Turnaround Station – All Cargo, Side Door Loading: Model 747-400 Freighter, -400ER Freighter	5-9
5.2.6	Terminal Operations – Turnaround Station – All Cargo, Nose and Side Cargo Door Loading: Model 747-400 Freighter, -400ER Freighter	5-10
5.3	TERMINAL OPERATIONS - EN ROUTE STATION.....	5-11
5.3.1	Terminal Operations - En Route Station - All Passenger: Model 747-400, -400 Combi, -400 Domestic.....	5-11
5.3.2	Terminal Operations - En Route Station - All Passenger: Model 747-400ER	5-12
5.4	GROUND SERVICING CONNECTIONS.....	5-13
5.4.1	Ground Service Connections: Model 747-400.....	5-13
5.4.2	Ground Service Connections: Model 747-400.....	5-14
5.4.3	Ground Servicing Connections: Model 747-400	5-15
5.5	ENGINE STARTING PNEUMATIC REQUIREMENTS	5-16
5.5.1	Engine Start Pneumatic Requirements - Sea Level: Model 747-400 (CF6-80C2B1 Engines, Garrett Starter).....	5-16
5.5.2	Engine Start Pneumatic Requirements - Sea Level: Model 747-400 (CF6-80C2B1 Engines, Hamilton Standard Starter).....	5-17
5.5.3	Engine Start Pneumatic Requirements - Sea Level: Model 747-400 (PW 4056 Engines, Garrett Starter)	5-18
5.5.4	Engine Start Pneumatic Requirements - Sea Level: Model 747-400 (PW 4056 Engines, Hamilton Standard Starter)	5-19
5.5.5	Engine Start Pneumatic Requirements - Sea Level: Model 747-400 (RB211-524G Engines).....	5-20
5.6	GROUND PNEUMATIC POWER REQUIREMENTS	5-21
5.6.1	Ground Pneumatic Power Requirements - Heating/Cooling: Model 747-400	5-21
5.7	CONDITIONED AIR REQUIREMENTS	5-22
5.7.1	Conditioned Air Flow Requirements: Model 747-400	5-22
5.8	GROUND TOWING REQUIREMENTS	5-23
5.8.1	Ground Towing Requirements - English Units: Model 747-400.....	5-23

5.8.2	Ground Towing Requirements - Metric Units: Model 747-400	5-24
6.0	JET ENGINE WAKE AND NOISE DATA	6-1
6.1	JET ENGINE EXHAUST VELOCITIES AND TEMPERATURES	6-1
6.1.1	Jet Engine Exhaust Velocity Contours – Idle Thrust: Model 747-400.....	6-2
6.1.2	Jet Engine Exhaust Velocity Contours – Breakaway Thrust – Level Pavement: Model 747-400, -400 Combi, -400 Domestic, -400 Freighter	6-3
6.1.3	Jet Engine Exhaust Velocity Contours – Breakaway Thrust - Level Pavement Upslope: Model 747-400ER, -400ER Freighter.....	6-4
6.1.4	Jet Engine Exhaust Velocity Contours - Breakaway Thrust - 1.5% Pavement Upslope: Model 747-400ER, -400ER Freighter.....	6-5
6.1.5	Jet Engine Exhaust Velocity Contours - Takeoff Thrust: Model 747-400	6-6
6.1.6	Jet Engine Exhaust Temperature Contours – Idle/Breakaway Thrust: Model 747-400	6-7
6.1.7	Jet Engine Exhaust Temperature Contours - Takeoff Thrust: Model 747-400	6-8
6.1.8	Inlet Hazard Areas: All Models	6-9
6.2	AIRPORT AND COMMUNITY NOISE.....	6-10
7.0	PAVEMENT DATA	7-1
7.1	GENERAL INFORMATION.....	7-1
7.2	LANDING GEAR FOOTPRINT	7-4
7.2.1	Landing Gear Footprint: Model 747-400, -400 Combi, -400 Domestic	7-4
7.2.2	Landing Gear Footprint: Model 747-400 Freighter	7-5
7.2.3	Landing Gear Footprint: Model 747-400ER, -400ER Freighter.....	7-6
7.3	MAXIMUM PAVEMENT LOADS: MODEL 747-400.....	7-7
7.4	LANDING GEAR LOADING ON PAVEMENT	7-8
7.4.1	Landing Gear Loading on Pavement: Model 747-400, -400 Combi, -400 Domestic	7-8
7.4.2	Landing Gear Loading on Pavement: Model 747-400 Freighter	7-9
7.4.3	Landing Gear Loading On Pavement: Model 747-400ER.....	7-10
7.4.4	Landing Gear Loading On Pavement: Model 747-400ER Freighter	7-11
7.5	FLEXIBLE PAVEMENT REQUIREMENTS - U.S. ARMY CORPS OF ENGINEERS METHOD (S-77-1) AND FAA DESIGN METHOD	7-12
7.5.1	Flexible Pavement Requirements - U.S. Army Corps of Engineers Design Method (S-77-1) and FAA Design Method: Model 747-400, -400 Combi, -400 Domestic, -400 Freighter	7-13
7.5.2	Flexible Pavement Requirements - U.S. Army Corps of Engineers Design Method (S-77-1): Model 747-400ER, -400ER Freighter	7-14

7.6	FLEXIBLE PAVEMENT REQUIREMENTS - LCN METHOD	7-15
7.6.1	Flexible Pavement Requirements - LCN Method: Model 747-400, -400 Combi, -400 Domestic, -400 Freighter	7-16
7.6.2	Flexible Pavement Requirements - LCN METHOD: Model 747-400ER, -400ER Freighter	7-17
7.7	RIGID PAVEMENT REQUIREMENTS - PORTLAND CEMENT ASSOCIATION DESIGN METHOD	7-18
7.7.1	Rigid Pavement Requirements - Portland Cement Association Design Method: Model 747-400, -400 Combi, -400 Domestic, -400 Freighter	7-19
7.7.2	Rigid Pavement Requirements - Portland Cement Association Design Method: Model 747-400ER, -400ER Freighter	7-20
7.8	RIGID PAVEMENT REQUIREMENTS - LCN CONVERSION	7-21
7.8.1	Radius of Relative Stiffness (Reference: Portland Cement Association).....	7-21
7.8.2	Rigid Pavement Requirements - LCN Conversion: Model 747-400, -400 Combi, -400 Domestic, -400 Freighter	7-23
7.8.3	Rigid Pavement Requirements - LCN Conversion: Model 747-400ER, -400ER Freighter	7-24
7.9	RIGID PAVEMENT REQUIREMENTS - FAA DESIGN METHOD	7-25
7.9.1	Rigid Pavement Requirements - FAA Design Method: Model 747-400, -400 Combi, -400 Domestic, -400 Freighter.....	7-26
7.9.2	Pavement Requirements - FAA Design Method: Model 747-400ER, -400ER Freighter.....	7-27
7.10	ACN/PCN REPORTING SYSTEM - FLEXIBLE AND RIGID PAVEMENTS	7-28
7.10.1	Aircraft Classification Number - Flexible Pavement: Model 747-400, -400 Combi, -400 Domestic, -400 Freighter	7-29
7.10.2	Aircraft Classification Number - Flexible Pavement: Model 747-400ER, -400er Freighter	7-30
7.10.3	Aircraft Classification Number - Rigid Pavement: Model 747-400, -400 Combi, -400 Domestic, -400 Freighter	7-31
7.10.4	Aircraft Classification Number - Rigid Pavement: Model 747-400ER, -400ER Freighter.....	7-32
7.11	ACR/PCR REPORTING SYSTEM – FLEXIBLE AND RIGID PAVEMENTS	7-1
7.11.1	Aircraft Classification Rating - Flexible Pavement: Model 747-400B	7-2
7.11.2	Aircraft Classification Rating - Flexible Pavement: Model 747-400BC	7-3
7.11.3	Aircraft Classification Rating - Flexible Pavement: Model 747-400BCF	7-4

7.11.4	Aircraft Classification Rating - Flexible Pavement: Model 747-400ER.....	7-5
7.11.5	Aircraft Classification Rating - Flexible Pavement: Model 747-400ERF	7-6
7.11.6	Aircraft Classification Rating - Flexible Pavement: Model 747-400F.....	7-7
7.11.7	Aircraft Classification Rating - Flexible Pavement: Model 747-400LCF	7-8
7.11.8	Aircraft Classification Rating - Rigid Pavement: Model 747-400B.....	7-9
7.11.9	Aircraft Classification Rating - Rigid Pavement: Model 747-400BC	7-10
7.11.10	Aircraft Classification Rating - Rigid Pavement: Model 747-400BCF	7-11
7.11.11	Aircraft Classification Rating - Rigid Pavement: Model 747-400ER.....	7-12
7.11.12	Aircraft Classification Rating - Rigid Pavement: Model 747-400ERF	7-13
7.11.13	Aircraft Classification Rating - Rigid Pavement: Model 747-400F	7-14
7.11.14	Aircraft Classification Rating - Rigid Pavement: Model 747-400LCF	7-15
8.0	FUTURE 747 DERIVATIVE AIRPLANES.....	8-1
9.0	SCALED 747-400 DRAWINGS.....	9-1
9.1	MODEL 747-400, -400 COMBI, -400ER.....	9-2
9.1.1	Scaled Drawings – 1 IN. = 32 FT: Model 747-400, -400 Combi, -400ER	9-2
9.1.2	Scaled Drawings – 1 IN. = 32 FT: Model 747-400, -400 Combi, -400ER	9-3
9.1.3	Scaled Drawings – 1 IN. = 50 FT: Model 747-400, -400 Combi, -400ER	9-4
9.1.4	Scaled Drawings – 1 IN. = 50 FT: Model 747-400, -400 Combi, -400ER	9-5
9.1.5	Scaled Drawings – 1 IN. = 100 FT: Model 747-400, -400 Combi, -400ER	9-6
9.1.6	Scaled Drawings – 1 IN. = 100 FT: Model 747-400, -400 Combi, -400ER	9-7
9.1.7	Scaled Drawings – 1:500: Model 747-400, -400 Combi, -400ER.....	9-8
9.1.8	Scaled Drawings – 1:500: Model 747-400, -400 Combi, -400ER.....	9-9
9.1.9	Scaled Drawings – 1:1000: Model 747-400, -400 Combi, -400ER.....	9-10
9.1.10	Scaled Drawings – 1:1000: Model 747-400, -400 Combi, -400ER.....	9-11
9.2	MODEL 747-400 FREIGHTER, -400ER FREIGHTER	9-12
9.2.1	Scaled Drawings – 1 IN. = 32 FT: Model 747-400 Freighter, -400ER Freighter	9-12

9.2.2	Scaled Drawings – 1 IN. = 32 FT: Model 747-400 Freighter, -400ER Freighter	9-13
9.2.3	Scaled Drawings – 1 IN. = 50 FT: Model 747-400 Freighter, -400ER Freighter	9-14
9.2.4	Scaled Drawings – 1 IN. = 50 FT: Model 747-400 Freighter, -400ER Freighter	9-15
9.2.5	Scaled Drawings – 1 IN. = 100 FT: Model 747-400 Freighter, -400ER Freighter	9-16
9.2.6	Scaled Drawings – 1 IN. = 100 FT: Model 747-400 Freighter, -400ER Freighter	9-17
9.2.7	Scaled Drawings – 1:500: Model 747-400 Freighter, -400ER Freighter	9-18
9.2.8	Scaled Drawings – 1:500: Model 747-400 Freighter, -400ER Freighter	9-19
9.2.9	Scaled Drawings – 1:1000: Model 747-400 Freighter, -400ER Freighter	9-20
9.2.10	Scaled Drawings – 1:1000: Model 747-400 Freighter, -400ER Freighter	9-21
9.3	MODEL 747-400 DOMESTIC	9-22
9.3.1	Scaled Drawings – 1 IN. = 32 FT: Model 747-400 Domestic	9-22
9.3.2	Scaled Drawings – 1 IN. = 32 FT: Model 747-400 Domestic	9-23
9.3.3	Scaled Drawings – 1 IN. = 50 FT: Model 747-400 Domestic	9-24
9.3.4	Scaled Drawings – 1 IN. = 50 FT: Model 747-400 Domestic	9-25
9.3.5	Scaled Drawings – 1 IN. = 100 FT: Model 747-400 Domestic	9-26
9.3.6	Scaled Drawings – 1 IN. = 100 FT: Model 747-400 Domestic	9-27
9.3.7	Scaled Drawings – 1:500: Model 747-400 Domestic	9-28
9.3.8	Scaled Drawings – 1:500: Model 747-400 Domestic	9-29
9.3.9	Scaled Drawings – 1:1000: Model 747-400 Domestic	9-30
9.3.10	Scaled Drawings – 1:1000: Model 747-400 Domestic	9-31

1.0 SCOPE AND INTRODUCTION

1.1 SCOPE

This document provides, in a standardized format, airplane characteristics data for general airport planning. Since operational practices vary among airlines, specific data should be coordinated with the using airlines prior to facility design. Boeing Commercial Airplanes should be contacted for any additional information required.

Content of the document reflects the results of a coordinated effort by representatives from the following organizations:

- Aerospace Industries Association
- Airport Operators Council International
- Air Transport Association of America
- International Air Transport Association

The airport planner may also want to consider the information presented in the "CTOL Transport Aircraft, Characteristics, Trends, and Growth Projections," available from the US AIA, 1250 Eye St., Washington DC 20005, for long-range planning needs. This document is updated periodically and represents the coordinated efforts of the following organizations regarding future aircraft growth trends:

- International Coordinating Council of Aerospace Industries Associations
- Airports Council International
- Air Transport Association of America
- International Air Transport Association

1.2 INTRODUCTION

This document conforms to NAS 3601. It provides characteristics of the Boeing Model 747-400 airplane for airport planners and operators, airlines, architectural and engineering consultant organizations, and other interested industry agencies. Airplane changes and available options may alter model characteristics. The data presented herein reflect typical airplanes in each model category.

For additional information contact:

Boeing Commercial Airplanes
2201 Seal Beach Blvd. M/C: 110-SB02
Seal Beach, CA 90740-1515
U.S.A.

Attention: Manager, Airport Operations Engineering

Phone: 562-797-1172

Email: AirportCompatibility@boeing.com

1.3 A BRIEF DESCRIPTION OF THE 747-400

The 747-400 is the latest derivative of the 747 family of airplanes. The -400 is externally similar to the 747-300, with the additional wingtip extension with winglets and advanced high bypass ratio engines. Other characteristics unique to the 747-400 include:

- Two-crew cockpit with digital avionics
- Lightweight aluminum alloys
- Structural carbon brakes
- Optional 910,000-pound maximum takeoff weight
- Optional 3,300-gallon fuel tank in horizontal stabilizer
- Optional fuel tanks in forward cargo compartment
- Vacuum lavatories with single-point servicing
- Enhanced passenger appeal in cabin interior
- Optional crew rest compartment in aft cabin
- Fly-by-wire system

747-400

The basic 747-400 has a tri-class passenger interior arrangement. Optional arrangements include a two-class or a one-class configuration to suit traffic demands.

747-400 Domestic

The 747-400 Domestic is a high-capacity airplane designed for domestic short routes. It has a lighter maximum takeoff weight. The -400D airplane has the same wingspan planform as the -300 and has no winglets.

747-400 Combi

The 747-400 Combi airplane has a main deck cargo door installed on the left side aft of the wing. This door is used for loading pallets or containerized cargo up to 20 feet long. The main deck of the Combi airplane can be converted to either an all-passenger or a passenger/cargo configuration. In the latter configuration, cargo is in the aft fuselage. Several cargo configurations can be loaded compatible with size limits and operational procedures. The Combi can accommodate up to seven 10-foot pallets or containers.

747-400 Freighter

The 747-400 Freighter has a main deck nose door and a mechanized cargo handling system. The nose door swings up so that pallets or containers up to 40 ft (12 m) can be loaded straight in on motor-driven rollers. An optional main deck side cargo door (like the 747-400 Combi) allows loading of dimensionally taller cargo modules.

747-400ER

The 747-400ER is an increased gross weight derivative of the 747-400. The increased weight allows it carry additional fuel in order to fly over longer ranges. The 747-400ER can be equipped with up to two 3,060-gallon fuel tanks in the forward lower cargo compartment.

747-400ER Freighter

The 747-400ER Freighter is similar to the 747-400 Freighter, except for the increased gross weight capability which allows it to carry more cargo weight. This airplane is not fitted with the cargo compartment fuel tanks.

Engines

The 747-400 is equipped with four advanced high bypass ratio engines. The following table shows the available engines:

MANUFACTURER	MODEL NUMBER	RATED TAKEOFF THRUST (LB)
GENERAL ELECTRIC	CF6-80C2B1F	57,900
PRATT & WHITNEY	PW4056	56,750
ROLLS-ROYCE	RB211-524G2	58,000

The 747-400ER is equipped with four advanced high bypass ratio engines. The following table shows the available engines:

MANUFACTURER	MODEL NUMBER	RATED TAKEOFF THRUST (LB)
GENERAL ELECTRIC	CF6-80C2B5F	62,100
PRATT & WHITNEY	PW4062	63,300
ROLLS-ROYCE	RB211-524H8-T	59,500

Additional models of the above engines may be available through customer options.

Crew Rest Compartment

The 747-400 can be equipped with a cabin crew rest compartment. This is located in the aft cabin above the ceiling at Door No. 5. The compartment can be configured to a combination of bunks and seats for up to 10 crew members. Access to the compartment is through a ladder near Right Door No. 5. This is standard on the 747-400ER.

Another compartment is located in the upper deck, outside of the cockpit.

Document Applicability

This document (D6-58326-1) contains airplane characteristics data for the 747-400 and 747-400ER airplanes.

Document D6-58326-2, which contained preliminary airplane characteristics information for the 747-400ER airplanes is now cancelled and will not be revised and should be discarded.

The earlier airplane models (747-100, -200, -300, SP) are described in Document

D6-58326, 747 Airplane Characteristics for Airport Planning.

2.0 AIRPLANE DESCRIPTION

2.1 GENERAL CHARACTERISTICS

Maximum Design Taxi Weight (MTW). Maximum weight for ground maneuver as limited by aircraft strength and airworthiness requirements. (It includes weight of taxi and run-up fuel.)

Maximum Design Landing Weight (MLW). Maximum weight for landing as limited by aircraft strength and airworthiness requirements.

Maximum Design Takeoff Weight (MTOW). Maximum weight for takeoff as limited by aircraft strength and airworthiness requirements. (This is the maximum weight at start of the takeoff run.)

Operating Empty Weight (OEW). Weight of structure, powerplant, furnishing systems, unusable fuel and other unusable propulsion agents, and other items of equipment that are considered an integral part of a particular airplane configuration. Also included are certain standard items, personnel, equipment, and supplies necessary for full operations, excluding usable fuel and payload.

Maximum Design Zero Fuel Weight (MZFW). Maximum weight allowed before usable fuel and other specified usable agents must be loaded in defined sections of the aircraft as limited by strength and airworthiness requirements.

Maximum Payload. Maximum design zero fuel weight minus operational empty weight.

Maximum Seating Capacity. The maximum number of passengers specifically certificated or anticipated for certification.

Maximum Cargo Volume. The maximum space available for cargo.

Usable Fuel. Fuel available for aircraft propulsion.

2.1.1 General Characteristics: Model 747-400 (General Electric Engines)

CHARACTERISTICS	UNITS	CF6-80C2B1 ENGINES				
MAX DESIGN TAXI WEIGHT	POUNDS	803,000	836,000	853,000	873,000	877,000
	KILOGRAMS	364,235	379,204	386,915	395,987	397,801
MAX DESIGN TAKEOFF WEIGHT	POUNDS	800,000	833,000	850,000	870,000	875,000
	KILOGRAMS	362,874	377,843	385,554	394,626	396,894
MAX DESIGN LANDING WEIGHT (1)	POUNDS	574,000	574,000	630,000	630,000	630,000
	KILOGRAMS	260,362	260,362	285,764	285,764	285,764
MAX DESIGN ZERO FUEL WEIGHT (2)	POUNDS	535,000	535,000	535,000	542,500	542,500
	KILOGRAMS	242,672	242,672	242,672	246,074	246,074
SPEC OPERATING EMPTY WEIGHT (3)	POUNDS	394,088	394,088	394,088	394,088	394,088
	KILOGRAMS	178,756	178,756	178,756	178,756	178,756
MAX STRUCTURAL PAYLOAD	POUNDS	140,912	140,912	140,912	148,412	148,412
	KILOGRAMS	63,917	63,917	63,917	67,319	67,319
TYPICAL SEATING CAPACITY (INCLUDES UPPER DECK)	UPPER DECK	42 BUSINESS CLASS				
	MAIN DECK	24 FIRST, 32 BUSINESS, 302 ECONOMY				
MAX CARGO - LOWER DECK CONTAINERS (LD-1)	CUBIC FEET	5,536	5,536	5,536	5,536	5,536
	CUBIC METERS	157	157	157	157	157
MAX CARGO - LOWER DECK BULK CARGO	CUBIC FEET	835	835	835	835	835
	CUBIC METERS	24	24	24	24	24
USABLE FUEL CAPACITY (4)	U.S. GALLONS	53,765	53,763	53,765	57,065	57,065
	LITERS	203,501	203,493	203,501	215,991	215,991
	POUNDS	360,226	360,226	360,226	382,336	382,336
	KILOGRAMS	163,396	163,396	163,396	173,425	173,425

NOTES:

- 630,000 LB LANDING WEIGHT IS OPTIONAL
- 542,500 LB ZERO FUEL WEIGHT IS OPTIONAL
- SPEC OPERATING EMPTY WEIGHT REFLECTS THREE-CLASS 400-PASSENGER ARRANGEMENT AND STANDARD ITEM ALLOWANCES. ACTUAL OEW WILL VARY WITH AIRPLANE CONFIGURATION. CONSULT USING AIRLINE FOR ACTUAL OEW.
- OPTIONAL TAIL FUEL OF 3,300 US GAL IS REFLECTED IN THE HIGHER FUEL CAPACITY.

2.1.2 General Characteristics: Model 747-400 (Pratt & Whitney Engines)

CHARACTERISTICS	UNITS	PW 4056 ENGINES				
MAX DESIGN TAXI WEIGHT	POUNDS	803,000	836,000	853,000	873,000	877,000
	KILOGRAMS	364,235	379,204	386,915	395,987	397,801
MAX DESIGN TAKEOFF WEIGHT	POUNDS	800,000	833,000	850,000	870,000	875,000
	KILOGRAMS	362,874	377,843	385,554	394,626	396,894
MAX DESIGN LANDING WEIGHT (1)	POUNDS	574,000	574,000	630,000	630,000	630,000
	KILOGRAMS	260,362	260,362	285,764	285,764	285,764
MAX DESIGN ZERO FUEL WEIGHT (2)	POUNDS	535,000	535,000	535,000	542,500	542,500
	KILOGRAMS	242,672	242,672	242,672	246,074	246,074
SPEC OPERATING EMPTY WEIGHT (3)	POUNDS	394,660	394,660	394,660	394,660	394,660
	KILOGRAMS	179,015	179,015	179,015	179,015	179,015
MAX STRUCTURAL PAYLOAD	POUNDS	140,340	140,340	140,340	147,840	147,840
	KILOGRAMS	63,657	63,657	63,657	67,059	67,059
TYPICAL SEATING CAPACITY (INCLUDES UPPER DECK)	UPPER DECK	42 BUSINESS CLASS				
	MAIN DECK	24 FIRST, 32 BUSINESS, 302 ECONOMY				
MAX CARGO - LOWER DECK CONTAINERS (LD-1)	CUBIC FEET	5,536	5,536	5,536	5,536	5,536
	CUBIC METERS	157	157	157	157	157
MAX CARGO - LOWER DECK BULK CARGO	CUBIC FEET	835	835	835	835	835
	CUBIC METERS	24	24	24	24	24
USABLE FUEL CAPACITY (4)	U.S. GALLONS	53,985	53,985	53,985	57,285	57,285
	LITERS	204,333	204,333	204,333	216,824	216,824
	POUNDS	361,700	361,700	361,700	383,810	383,810
	KILOGRAMS	164,064	164,064	164,064	174,093	174,093

NOTES:

- 630,000 LB LANDING WEIGHT IS OPTIONAL
- 542,500 LB ZERO FUEL WEIGHT IS OPTIONAL
- SPEC OPERATING EMPTY WEIGHT REFLECTS THREE-CLASS 400-PASSENGER ARRANGEMENT AND STANDARD ITEM ALLOWANCES. ACTUAL OEW WILL VARY WITH AIRLINE CONFIGURATION AND OPTIONAL EQUIPMENT. CONSULT USING AIRLINE FOR ACTUAL OEW.
- OPTIONAL TAIL FUEL OF 3,300 US GAL IS REFLECTED IN THE HIGHER FUEL CAPACITY.

2.1.3 General Characteristics: Model 747-400 (Rolls-Royce Engines)

CHARACTERISTICS	UNITS	RB211-524G2 ENGINES				
MAX DESIGN TAXI WEIGHT	POUNDS	803,000	836,000	853,000	873,000	877,000
	KILOGRAMS	364,235	379,204	386,915	395,987	397,801
MAX DESIGN TAKEOFF WEIGHT	POUNDS	800,000	833,000	850,000	870,000	875,000
	KILOGRAMS	362,874	377,843	385,554	394,626	396,894
MAX DESIGN LANDING WEIGHT (1)	POUNDS	574,000	574,000	630,000	630,000	630,000
	KILOGRAMS	260,362	260,362	285,764	285,764	285,764
MAX DESIGN ZERO FUEL WEIGHT (2)	POUNDS	535,000	535,000	535,000	545,000	545,000
	KILOGRAMS	242,672	242,672	242,672	247,208	247,208
SPEC OPERATING EMPTY WEIGHT (3)	POUNDS	396,284	396,284	396,284	396,284	396,284
	KILOGRAMS	179,752	179,752	179,752	179,752	179,752
MAX STRUCTURAL PAYLOAD	POUNDS	138,716	138,716	138,716	148,716	148,716
	KILOGRAMS	62,921	62,921	62,921	67,457	67,457
TYPICAL SEATING CAPACITY (INCLUDES UPPER DECK)	UPPER DECK	42 BUSINESS CLASS				
	MAIN DECK	24 FIRST, 32 BUSINESS, 302 ECONOMY				
MAX CARGO - LOWER DECK CONTAINERS (LD-1)	CUBIC FEET	5,536	5,536	5,536	5,536	5,536
	CUBIC METERS	157	157	157	157	157
MAX CARGO - LOWER DECK BULK CARGO	CUBIC FEET	835	835	835	835	835
	CUBIC METERS	24	24	24	24	24
USABLE FUEL CAPACITY (4)	U.S. GALLONS	53,985	53,985	53,985	57,285	57,285
	LITERS	204,333	204,333	204,333	216,824	216,824
	POUNDS	361,700	361,700	361,700	383,810	383,810
	KILOGRAMS	164,064	164,064	164,064	174,093	174,093

NOTES:

- 630,000 LB LANDING WEIGHT IS OPTIONAL
- 545,000 LB ZERO FUEL WEIGHT IS OPTIONAL
- SPEC OPERATING EMPTY WEIGHT REFLECTS THREE-CLASS 400-PASSENGER ARRANGEMENT AND STANDARD ITEM ALLOWANCES. ACTUAL OEW WILL VARY WITH AIRLINE CONFIGURATION AND OPTIONAL EQUIPMENT. CONSULT USING AIRLINE FOR ACTUAL OEW.
- OPTIONAL TAIL FUEL OF 3,300 US GAL IS REFLECTED IN THE HIGHER FUEL CAPACITY.

2.1.4 General Characteristics: Model 747-400 Combi (General Electric Engines)

CHARACTERISTICS	UNITS	CF6-80C2B1 ENGINES				
MAX DESIGN TAXI WEIGHT	POUNDS	803,000	836,000	853,000	873,000	877,000
	KILOGRAMS	364,235	379,204	386,915	395,987	397,801
MAX DESIGN TAKEOFF WEIGHT	POUNDS	800,000	833,000	850,000	870,000	875,000
	KILOGRAMS	362,874	377,843	385,554	394,626	396,894
MAX DESIGN LANDING WEIGHT (1)	POUNDS	574,000	574,000	630,000	630,000	630,000
	KILOGRAMS	260,362	260,362	285,764	285,764	285,764
MAX DESIGN ZERO FUEL WEIGHT (2)	POUNDS	545,000	545,000	545,000	565,000	565,000
	KILOGRAMS	247,208	247,208	247,208	256,280	256,280
SPEC OPERATING EMPTY WEIGHT (3)	POUNDS	407,107	407,107	407,107	402,900	402,900
	KILOGRAMS	184,661	184,661	184,661	182,753	182,753
MAX STRUCTURAL PAYLOAD	POUNDS	137,893	137,893	137,893	162,100	162,100
	KILOGRAMS	62,547	62,547	62,547	73,527	73,527
TYPICAL SEATING CAPACITY (INCLUDES UPPER DECK)	UPPER DECK	400: 24 FIRST, 74 BUSINESS, 302 ECONOMY				
	MAIN DECK	345: 28 FIRST, 110 BUSINESS, 207 ECONOMY, 7 PALLETS				
MAX CARGO - MAIN DECK PALLETS (4)	CUBIC FEET	4,290	4,290	4,290	4,290	4,290
	CUBIC METERS	122	122	122	122	122
MAX CARGO - LOWER DECK CONTAINERS (LD-1)	CUBIC FEET	5,536	5,536	5,536	5,536	5,536
	CUBIC METERS	157	157	157	157	157
MAX CARGO - LOWER DECK BULK CARGO	CUBIC FEET	710	710	710	710	710
	CUBIC METERS	20	20	20	20	20
USABLE FUEL CAPACITY (5)	U.S. GALLONS	53,765	53,763	53,765	57,065	57,065
	LITERS	203,501	203,493	203,501	215,991	215,991
	POUNDS	360,226	360,226	360,226	382,336	382,336
	KILOGRAMS	163,396	163,396	163,396	173,425	173,425

NOTES:

- 630,000 LB LANDING WEIGHT IS OPTIONAL
- 565,000 LB ZERO FUEL WEIGHT IS OPTIONAL
- SPEC OPERATING EMPTY WEIGHT REFLECTS THREE-CLASS 400-PASSENGER ARRANGEMENT AND STANDARD ITEM ALLOWANCES. ACTUAL OEW WILL VARY WITH AIRLINE CONFIGURATION AND OPTIONAL EQUIPMENT. CONSULT USING AIRLINE FOR ACTUAL OEW. THE LOWER OEW VALUE REFLECTS PASSENGER/CARGO CONFIGURATION.
- SEVEN PALLETS AT 613 CUBIC FEET EACH
- OPTIONAL TAIL FUEL OF 3,300 US GAL IS REFLECTED IN THE HIGHER FUEL CAPACITY.

2.1.5 General Characteristics: Model 747-400 Combi (Pratt & Whitney Engines)

CHARACTERISTICS	UNITS	PW 4056 ENGINES				
MAX DESIGN TAXI WEIGHT	POUNDS	803,000	836,000	853,000	873,000	877,000
	KILOGRAMS	364,235	379,204	386,915	395,987	397,801
MAX DESIGN TAKEOFF WEIGHT	POUNDS	800,000	833,000	850,000	870,000	875,000
	KILOGRAMS	362,874	377,843	385,554	394,626	396,894
MAX DESIGN LANDING WEIGHT (1)	POUNDS	574,000	574,000	630,000	630,000	630,000
	KILOGRAMS	260,362	260,362	285,764	285,764	285,764
MAX DESIGN ZERO FUEL WEIGHT (2)	POUNDS	545,000	545,000	545,000	565,000	565,000
	KILOGRAMS	247,208	247,208	247,208	256,280	256,280
SPEC OPERATING EMPTY WEIGHT (3)	POUNDS	407,479	407,479	407,479	403,400	403,400
	KILOGRAMS	184,830	184,830	184,830	182,979	182,979
MAX STRUCTURAL PAYLOAD	POUNDS	137,521	137,521	137,521	161,600	161,600
	KILOGRAMS	62,379	62,379	62,379	73,301	73,301
TYPICAL SEATING CAPACITY (INCLUDES UPPER DECK)	PASSENGER	400: 24 FIRST, 74 BUSINESS, 302 ECONOMY				
	COMBI	345: 28 FIRST, 110 BUSINESS, 207 ECONOMY, 7 PALLETS				
MAX CARGO - MAIN DECK PALLETS (4)	CUBIC FEET	4,290	4,290	4,290	4,290	4,290
	CUBIC METERS	122	122	122	122	122
MAX CARGO - LOWER DECK CONTAINERS (LD-1)	CUBIC FEET	5,536	5,536	5,536	5,536	5,536
	CUBIC METERS	157	157	157	157	157
MAX CARGO - LOWER DECK BULK CARGO	CUBIC FEET	710	710	710	710	710
	CUBIC METERS	20	20	20	20	20
USABLE FUEL CAPACITY (5)	U.S. GALLONS	53,985	53,985	53,985	57,285	57,285
	LITERS	204,333	204,333	204,333	216,824	216,824
	POUNDS	361,700	361,700	361,700	383,810	383,810
	KILOGRAMS	164,064	164,064	164,064	174,093	174,093

NOTES:

- 630,000 LB LANDING WEIGHT IS OPTIONAL
- 565,000 LB ZERO FUEL WEIGHT IS OPTIONAL
- SPEC OPERATING EMPTY WEIGHT REFLECTS THREE-CLASS 400-PASSENGER ARRANGEMENT AND STANDARD ITEM ALLOWANCES. ACTUAL OEW WILL VARY WITH AIRLINE CONFIGURATION AND OPTIONAL EQUIPMENT. CONSULT USING AIRLINE FOR ACTUAL OEW. THE LOWER OEW VALUE REFLECTS PASSENGER/CARGO CONFIGURATION.
- SEVEN PALLETS AT 613 CUBIC FEET EACH
- OPTIONAL TAIL FUEL OF 3,300 US GAL IS REFLECTED IN THE HIGHER FUEL CAPACITY.

2.1.6 General Characteristics: Model 747-400 Combi (Rolls-Royce Engines)

CHARACTERISTICS	UNITS	RB211-534G2 ENGINES				
MAX DESIGN TAXI WEIGHT	POUNDS	803,000	836,000	853,000	873,000	877,000
	KILOGRAMS	364,235	379,204	386,915	395,987	397,801
MAX DESIGN TAKEOFF WEIGHT	POUNDS	800,000	833,000	850,000	870,000	875,000
	KILOGRAMS	362,874	377,843	385,554	394,626	396,894
MAX DESIGN LANDING WEIGHT (1)	POUNDS	574,000	574,000	630,000	630,000	630,000
	KILOGRAMS	260,362	260,362	285,764	285,764	285,764
MAX DESIGN ZERO FUEL WEIGHT (2)	POUNDS	545,000	545,000	545,000	565,000	565,000
	KILOGRAMS	247,208	247,208	247,208	256,280	256,280
SPEC OPERATING EMPTY WEIGHT (3)	POUNDS	410,103	410,103	410,103	405,900	405,900
	KILOGRAMS	186,020	186,020	186,020	184,113	184,113
MAX STRUCTURAL PAYLOAD	POUNDS	134,897	134,897	134,897	159,100	159,100
	KILOGRAMS	61,188	61,188	61,188	72,167	72,167
TYPICAL SEATING CAPACITY (INCLUDES UPPER DECK)	PASSENGER	400: 24 FIRST, 74 BUSINESS, 302 ECONOMY				
	COMBI	345: 28 FIRST, 110 BUSINESS, 207 ECONOMY, 7 PALLETS				
MAX CARGO - MAIN DECK PALLETS (4)	CUBIC FEET	4,290	4,290	4,290	4,290	4,290
	CUBIC METERS	122	122	122	122	122
MAX CARGO - LOWER DECK CONTAINERS (LD-1)	CUBIC FEET	5,536	5,536	5,536	5,536	5,536
	CUBIC METERS	157	157	157	157	157
MAX CARGO - LOWER DECK BULK CARGO	CUBIC FEET	710	710	710	710	710
	CUBIC METERS	20	20	20	20	20
USABLE FUEL CAPACITY (5)	U.S. GALLONS	53,985	53,985	53,985	57,285	57,285
	LITERS	204,333	204,333	204,333	216,824	216,824
	POUNDS	361,700	361,700	361,700	383,810	383,810
	KILOGRAMS	164,064	164,064	164,064	174,093	174,093

NOTES:

- 630,000 LB LANDING WEIGHT IS OPTIONAL
- 565,000 LB ZERO FUEL WEIGHT IS OPTIONAL
- SPEC OPERATING EMPTY WEIGHT REFLECTS THREE-CLASS 400-PASSENGER ARRANGEMENT AND STANDARD ITEM ALLOWANCES. ACTUAL OEW WILL VARY WITH AIRLINE CONFIGURATION AND OPTIONAL EQUIPMENT. CONSULT USING AIRLINE FOR ACTUAL OEW THE LOWER OEW VALUE REFLECTS PASSENGER/CARGO CONFIGURATION.
- SEVEN PALLETS AT 613 CUBIC FEET EACH
- OPTIONAL TAIL FUEL OF 3,300 US GAL IS REFLECTED IN THE HIGHER FUEL CAPACITY.

2.1.7 General Characteristics: Model 747-400 Freighter (General Electric Engines)

CHARACTERISTICS	UNITS	CF6-80C2B1 ENGINES				
MAX DESIGN TAXI WEIGHT	POUNDS	803,000	836,000	853,000	873,000	877,000
	KILOGRAMS	364,235	379,204	386,915	395,987	397,801
MAX DESIGN TAKEOFF WEIGHT	POUNDS	800,000	833,000	850,000	870,000	875,000
	KILOGRAMS	362,874	377,843	385,554	394,626	396,894
MAX DESIGN LANDING WEIGHT (1)	POUNDS	652,000	652,000	652,000	666,000	666,000
	KILOGRAMS	295,743	295,743	295,743	302,093	302,093
MAX DESIGN ZERO FUEL WEIGHT (2)	POUNDS	610,000	610,000	610,000	635,000	635,000
	KILOGRAMS	276,692	276,692	276,692	288,031	288,031
SPEC OPERATING EMPTY WEIGHT (3)	POUNDS	363,954	363,954	363,954	363,954	363,954
	KILOGRAMS	165,087	165,087	165,087	165,087	165,087
MAX STRUCTURAL PAYLOAD	POUNDS	246,046	246,046	246,046	271,046	271,046
	KILOGRAMS	111,605	111,605	111,605	122,945	122,945
TYPICAL CARGO – MAIN DECK CONTAINERS (4)	CUBIC FEET	18,720	18,720	18,720	18,720	18,720
	CUBIC METERS	530	530	530	530	530
MAX CARGO - LOWER DECK CONTAINERS (LD-1)	CUBIC FEET	5,536	5,536	5,536	5,536	5,536
	CUBIC METERS	157	157	157	157	157
MAX CARGO - LOWER DECK BULK CARGO	CUBIC FEET	520	520	520	520	520
	CUBIC METERS	15	15	15	15	15
USABLE FUEL CAPACITY (5)	U.S. GALLONS	53,765	53,763	53,765	57,065	57,065
	LITERS	203,501	203,493	203,501	215,991	215,991
	POUNDS	360,226	360,226	360,226	382,336	382,336
	KILOGRAMS	163,396	163,396	163,396	173,425	173,425

NOTES:

1. 666,000 LB LANDING WEIGHT IS OPTIONAL
2. 635,000 LB ZERO FUEL WEIGHT IS OPTIONAL
3. SPEC OPERATING EMPTY WEIGHT REFLECTS STANDARD ITEM ALLOWANCES. ACTUAL OEW WILL VARY WITH AIRPLANE CONFIGURATION. CONSULT WITH USING AIRLINE FOR ACTUAL OEW.
4. TWENTY-NINE 10-FT CONTAINERS. ACTUAL VOLUME WILL DEPEND ON AIRPLANE CONFIGURATION.
5. OPTIONAL TAIL FUEL OF 3,300 US GAL IS REFLECTED IN THE HIGHER FUEL CAPACITY.

2.1.8 General Characteristics: Model 747-400 Freighter (Pratt & Whitney Engines)

CHARACTERISTICS	UNITS	PW 4056 ENGINES				
MAX DESIGN TAXI WEIGHT	POUNDS	803,000	836,000	853,000	873,000	877,000
	KILOGRAMS	364,235	379,204	386,915	395,987	397,801
MAX DESIGN TAKEOFF WEIGHT	POUNDS	800,000	833,000	850,000	870,000	875,000
	KILOGRAMS	362,874	377,843	385,554	394,626	396,894
MAX DESIGN LANDING WEIGHT (1)	POUNDS	652,000	652,000	652,000	666,000	666,000
	KILOGRAMS	295,743	295,743	295,743	302,093	302,093
MAX DESIGN ZERO FUEL WEIGHT (2)	POUNDS	610,000	610,000	610,000	635,000	635,000
	KILOGRAMS	276,692	276,692	276,692	288,031	288,031
SPEC OPERATING EMPTY WEIGHT (3)	POUNDS	364,526	364,526	364,526	364,526	364,526
	KILOGRAMS	165,346	165,346	165,346	165,346	165,346
MAX STRUCTURAL PAYLOAD	POUNDS	245,474	245,474	245,474	270,474	270,474
	KILOGRAMS	111,345	111,345	111,345	122,685	122,685
TYPICAL CARGO – MAIN DECK CONTAINERS (4)	CUBIC FEET	18,720	18,720	18,720	18,720	18,720
	CUBIC METERS	530	530	530	530	530
MAX CARGO - LOWER DECK CONTAINERS (LD-1)	CUBIC FEET	5,536	5,536	5,536	5,536	5,536
	CUBIC METERS	157	157	157	157	157
MAX CARGO - LOWER DECK BULK CARGO	CUBIC FEET	520	520	520	520	520
	CUBIC METERS	15	15	15	15	15
USABLE FUEL CAPACITY (5)	U.S. GALLONS	53,985	53,985	53,985	57,285	57,285
	LITERS	204,333	204,333	204,333	216,824	216,824
	POUNDS	361,700	361,700	361,700	383,810	383,810
	KILOGRAMS	164,064	164,064	164,064	174,093	174,093

NOTES:

1. 666,000 LB LANDING WEIGHT IS OPTIONAL
2. 635,000 LB ZERO FUEL WEIGHT IS OPTIONAL
3. SPEC OPERATING EMPTY WEIGHT REFLECTS STANDARD ITEM ALLOWANCES. ACTUAL OEW WILL VARY WITH AIRPLANE CONFIGURATION. CONSULT WITH USING AIRLINE FOR ACTUAL OEW.
4. TWENTY-NINE 10-FT CONTAINERS. ACTUAL VOLUME WILL DEPEND ON AIRPLANE CONFIGURATION.
5. OPTIONAL TAIL FUEL OF 3,300 US GAL IS REFLECTED IN THE HIGHER FUEL CAPACITY.

2.1.9 General Characteristics: Model 747-400 Freighter (Rolls Royce Engines)

CHARACTERISTICS	UNITS	RB211-524G2 ENGINES				
MAX DESIGN TAXI WEIGHT	POUNDS	803,000	836,000	853,000	873,000	877,000
	KILOGRAMS	364,235	379,204	386,915	395,987	397,801
MAX DESIGN TAKEOFF WEIGHT	POUNDS	800,000	833,000	850,000	870,000	875,000
	KILOGRAMS	362,874	377,843	385,554	394,626	396,894
MAX DESIGN LANDING WEIGHT (1)	POUNDS	652,000	652,000	652,000	666,000	666,000
	KILOGRAMS	295,743	295,743	295,743	302,093	302,093
MAX DESIGN ZERO FUEL WEIGHT (2)	POUNDS	610,000	610,000	610,000	635,000	635,000
	KILOGRAMS	276,692	276,692	276,692	288,031	288,031
SPEC OPERATING EMPTY WEIGHT (3)	POUNDS	366,082	366,082	366,082	366,082	366,082
	KILOGRAMS	166,052	166,052	166,052	166,052	166,052
MAX STRUCTURAL PAYLOAD	POUNDS	243,850	243,850	243,850	268,850	268,850
	KILOGRAMS	110,609	110,609	110,609	121,948	121,948
TYPICAL CARGO – MAIN DECK CONTAINERS (4)	CUBIC FEET	18,720	18,720	18,720	18,720	18,720
	CUBIC METERS	530	530	530	530	530
MAX CARGO - LOWER DECK CONTAINERS (LD-1)	CUBIC FEET	5,536	5,536	5,536	5,536	5,536
	CUBIC METERS	157	157	157	157	157
MAX CARGO - LOWER DECK BULK CARGO	CUBIC FEET	520	520	520	520	520
	CUBIC METERS	15	15	15	15	15
USABLE FUEL CAPACITY (5)	U.S. GALLONS	53,985	53,985	53,985	57,285	57,285
	LITERS	204,333	204,333	204,333	216,824	216,824
	POUNDS	361,700	361,700	361,700	383,810	383,810
	KILOGRAMS	164,064	164,064	164,064	174,093	174,093

NOTES:

1. 666,000 LB LANDING WEIGHT IS OPTIONAL
2. 635,000 LB ZERO FUEL WEIGHT IS OPTIONAL
3. SPEC OPERATING EMPTY WEIGHT REFLECTS STANDARD ITEM ALLOWANCES. ACTUAL OEW WILL VARY WITH AIRPLANE CONFIGURATION. CONSULT WITH USING AIRLINE FOR ACTUAL OEW.
4. TWENTY-NINE 10-FT CONTAINERS. ACTUAL VOLUME WILL DEPEND ON AIRPLANE CONFIGURATION.
5. OPTIONAL TAIL FUEL OF 3,300 US GAL IS REFLECTED IN THE HIGHER FUEL CAPACITY.

2.1.10 General Characteristics: Model 747-400ER

CHARACTERISTICS	UNITS	GE ENGINES CF6-80C2B5-F	PW ENGINES PW4062	RR ENGINES RB211-524H8-T
MAX DESIGN TAXI WEIGHT	POUNDS	913,000	913,000	913,000
	KILOGRAMS	414,130	414,130	414,130
MAX DESIGN TAKEOFF WEIGHT	POUNDS	910,000	910,000	910,000
	KILOGRAMS	412,770	412,770	412,770
MAX DESIGN LANDING WEIGHT	POUNDS	652,000	652,000	652,000
	KILOGRAMS	295,743	295,743	295,743
MAX DESIGN ZERO FUEL WEIGHT	POUNDS	555,000	555,000	555,000
	KILOGRAMS	251,744	251,744	251,744
SPEC OPERATING EMPTY WEIGHT (1)	POUNDS	406,900	406,900	406,900
	KILOGRAMS	184,567	184,567	184,567
MAX STRUCTURAL PAYLOAD	POUNDS	148,100	148,100	148,100
	KILOGRAMS	67,177	67,177	67,177
TYPICAL SEATING CAPACITY (INCLUDES UPPER DECK)	TWO-CLASS	500: 42 FIRST CLASS, 458 ECONOMY CLASS		
	THREE-CLASS	416: 23 FIRST CLASS, 78 BUSINESS CLASS, 315 ECONOMY CLASS		
MAX CARGO - LOWER DECK LD-2 CONTAINERS (2)	CUBIC FEET	4,550	4,550	4,550
	CUBIC METERS	129	129	129
MAX CARGO - LOWER DECK BULK CARGO	CUBIC FEET	789	789	789
	CUBIC METERS	22	22	22
USABLE FUEL CAPACITY (3)	U.S. GALLONS	63,240	63,460	63,460
	LITERS	239,363	240,196	240,196
	POUNDS	423,708	425,182	425,182
	KILOGRAMS	192,191	192,860	192,860

NOTES:

1. SPEC OPERATING EMPTY WEIGHT REFLECTS THREE-CLASS 416-PASSENGER ARRANGEMENT AND STANDARD ITEM ALLOWANCES. ACTUAL OEW WILL VARY WITH AIRPLANE CONFIGURATION. CONSULT USING AIRLINE FOR ACTUAL OEW.
2. REFLECTS TWO BODY FUEL TANKS IN THE FORWARD CARGO COMPARTMENT.
3. INCLUDES TWO BODY FUEL TANKS OF 3,060 U.S. GALLONS EACH.

2.1.11 General Characteristics: Model 747-400ER Freighter

CHARACTERISTICS	UNITS	GE ENGINES CF6-80C2B5-F	PW ENGINES PW4062	RR ENGINES RB211-524H8-T
MAX DESIGN TAXI WEIGHT	POUNDS	913,000	913,000	913,000
	KILOGRAMS	414,130	414,130	414,130
MAX DESIGN TAKEOFF WEIGHT	POUNDS	910,000	910,000	910,000
	KILOGRAMS	412,770	412,770	412,770
MAX DESIGN LANDING WEIGHT	POUNDS	666,000	666,000	666,000
	KILOGRAMS	302,093	302,093	302,093
MAX DESIGN ZERO FUEL WEIGHT	POUNDS	611,000	611,000	611,000
	KILOGRAMS	277,145	277,145	277,145
SPEC OPERATING EMPTY WEIGHT (1)	POUNDS	362,400	362,400	362,400
	KILOGRAMS	164,382	164,382	164,382
MAX STRUCTURAL PAYLOAD	POUNDS	248,600	248,600	248,600
	KILOGRAMS	112,763	112,763	112,763
TYPICAL CARGO – MAIN DECK CONTAINERS (2)	CUBIC FEET	18,720	18,720	18,720
	CUBIC METERS	530	530	530
MAX CARGO - LOWER DECK CONTAINERS (LD-2)	CUBIC FEET	5,600	5,600	5,600
	CUBIC METERS	159	159	159
MAX CARGO - LOWER DECK BULK CARGO	CUBIC FEET	520	520	520
	CUBIC METERS	15	15	15
USABLE FUEL CAPACITY (3)	U.S. GALLONS	53,765	53,985	53,985
	LITERS	203,501	204,333	204,333
	POUNDS	360,226	361,700	361,700
	KILOGRAMS	163,396	164,064	164,064

NOTES:

1. SPEC OPERATING EMPTY WEIGHT REFLECTS STANDARD ITEM ALLOWANCES. ACTUAL OEW WILL VARY WITH AIRPLANE CONFIGURATION AND OPTIONAL EQUIPMENT. CONSULT USING AIRLINE FOR ACTUAL OEW.
2. TWENTY-NINE 10-FOOT CONTAINERS. ACTUAL VOLUME WILL DEPEND ON AIRPLANE CONFIGURATION.

2.1.12 General Characteristics: Model 747-400 Domestic (General Electric Engines)

CHARACTERISTICS	UNITS	CF6-80C2B1 ENGINES	
MAX DESIGN TAXI WEIGHT	POUNDS	603,000	613,500
	KILOGRAMS	273,517	278,279
MAX DESIGN TAKEOFF WEIGHT	POUNDS	600,000	610,000
	KILOGRAMS	272,156	276,692
MAX DESIGN LANDING WEIGHT	POUNDS	574,000	574,000
	KILOGRAMS	260,362	260,362
MAX DESIGN ZERO FUEL WEIGHT	POUNDS	535,000	535,000
	KILOGRAMS	242,672	242,672
SPEC OPERATING EMPTY WEIGHT (1)	POUNDS	400,630	400,630
	KILOGRAMS	181,723	181,723
MAX STRUCTURAL PAYLOAD	POUNDS	134,370	134,370
	KILOGRAMS	60,949	60,949
TYPICAL SEATING CAPACITY (INCLUDES UPPER DECK)	UPPER DECK	89 ECONOMY	
	MAIN DECK	539 ECONOMY	
MAX CARGO - LOWER DECK CONTAINERS (LD-1)	CUBIC FEET	5,600	5,600
	CUBIC METERS	159	159
MAX CARGO - LOWER DECK BULK CARGO	CUBIC FEET	835	835
	CUBIC METERS	24	24
USABLE FUEL CAPACITY	U.S. GALLONS	53,765	53,763
	LITERS	203,501	203,493
	POUNDS	360,226	360,226
	KILOGRAMS	163,396	163,396

NOTES:

1. SPEC OPERATING EMPTY WEIGHT REFLECTS ALL-ECONOMY 624-PASSENGER ARRANGEMENT AND STANDARD ITEM ALLOWANCES. ACTUAL OEW WILL VARY WITH AIRLINE CONFIGURATION AND OPTIONAL EQUIPMENT. CONSULT USING AIRLINE FOR ACTUAL OEW.

2.2 GENERAL DIMENSIONS

2.2.1 General Dimensions: Model 747-400, -400 Combi, -400ER

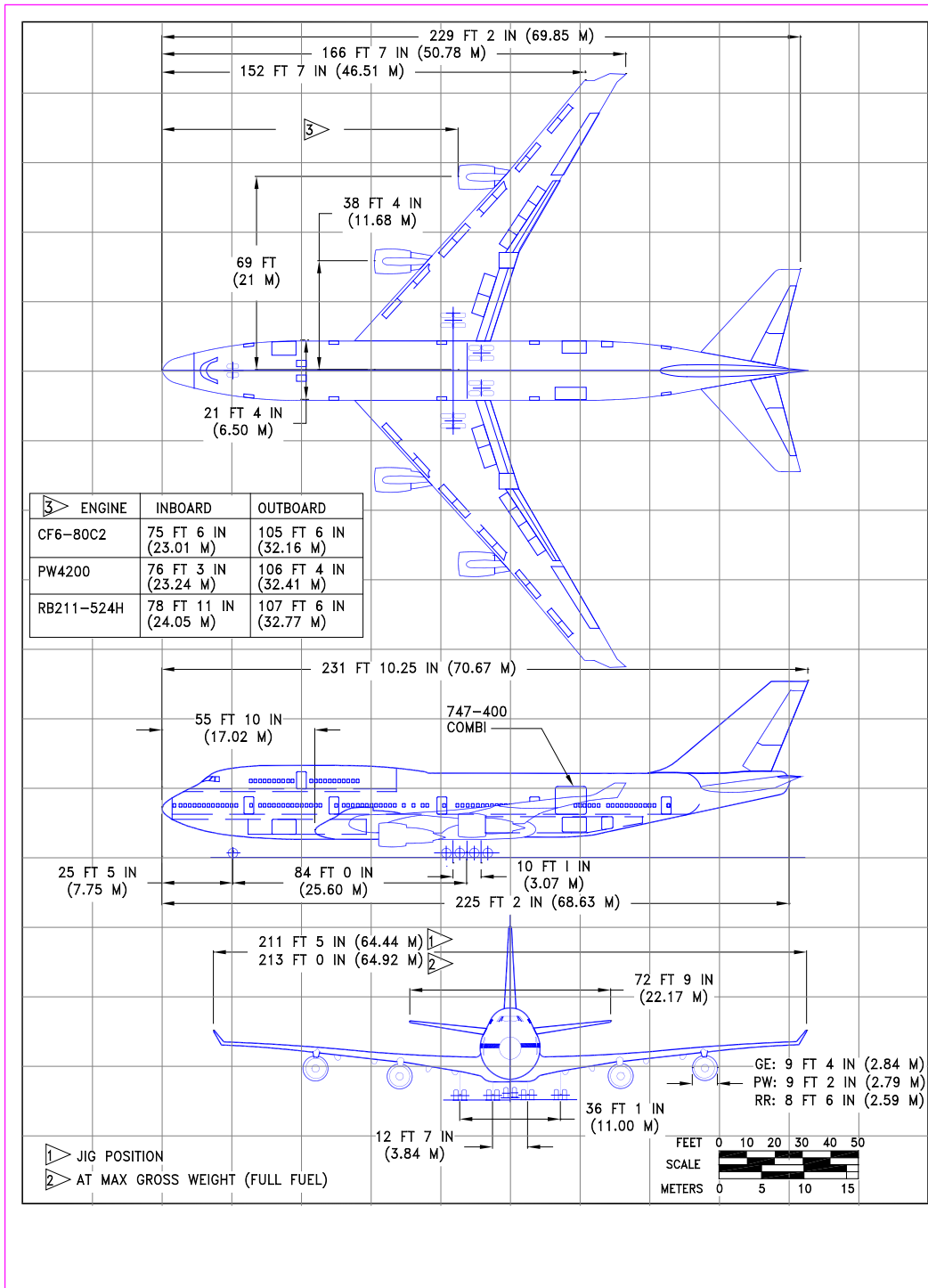

D6-58326-1

2.2.2 General Dimensions: Model 747-400 Freighter, -400ER Freighter

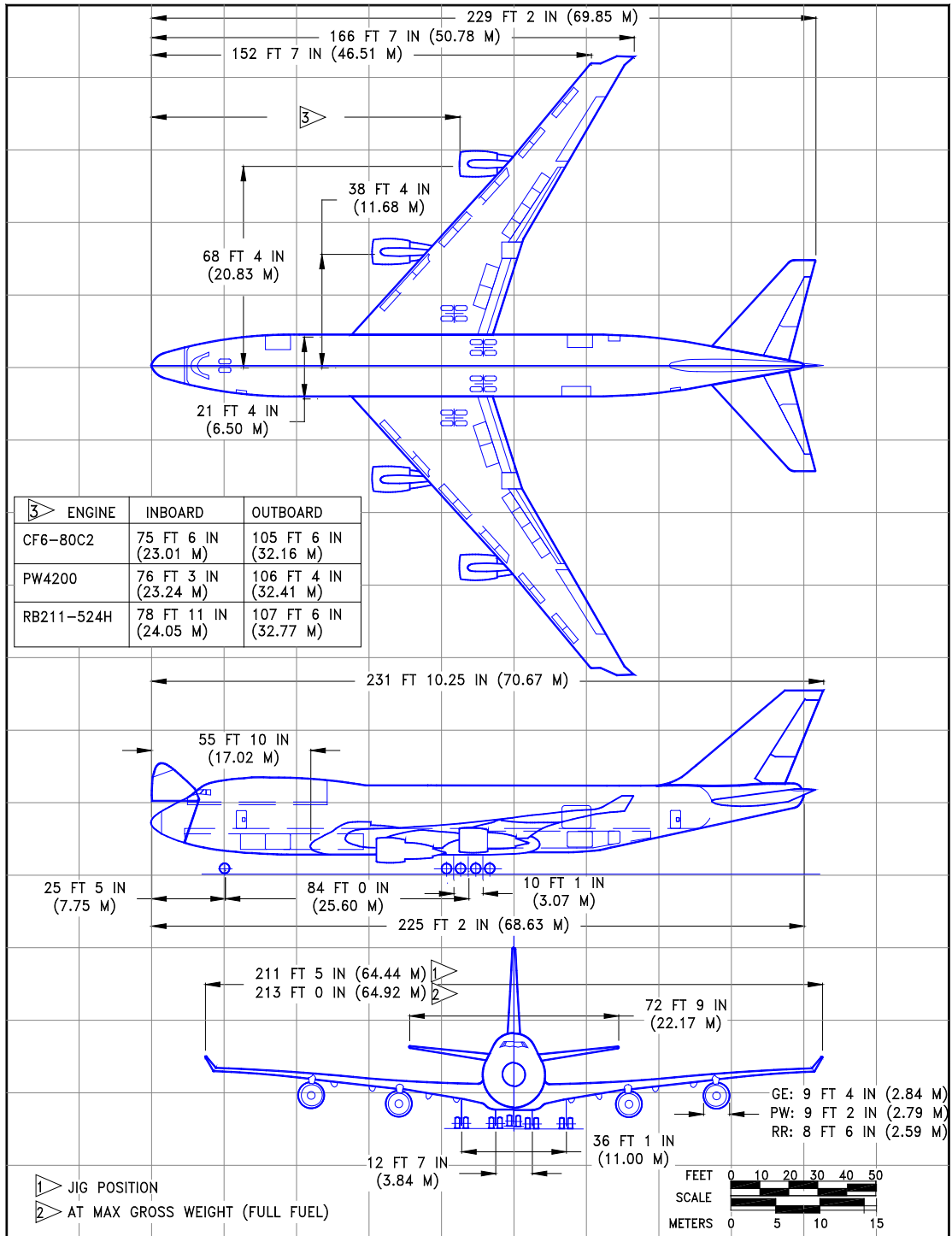

D6-58326-1

2.2.3 General Dimensions: Model 747-400 Domestic

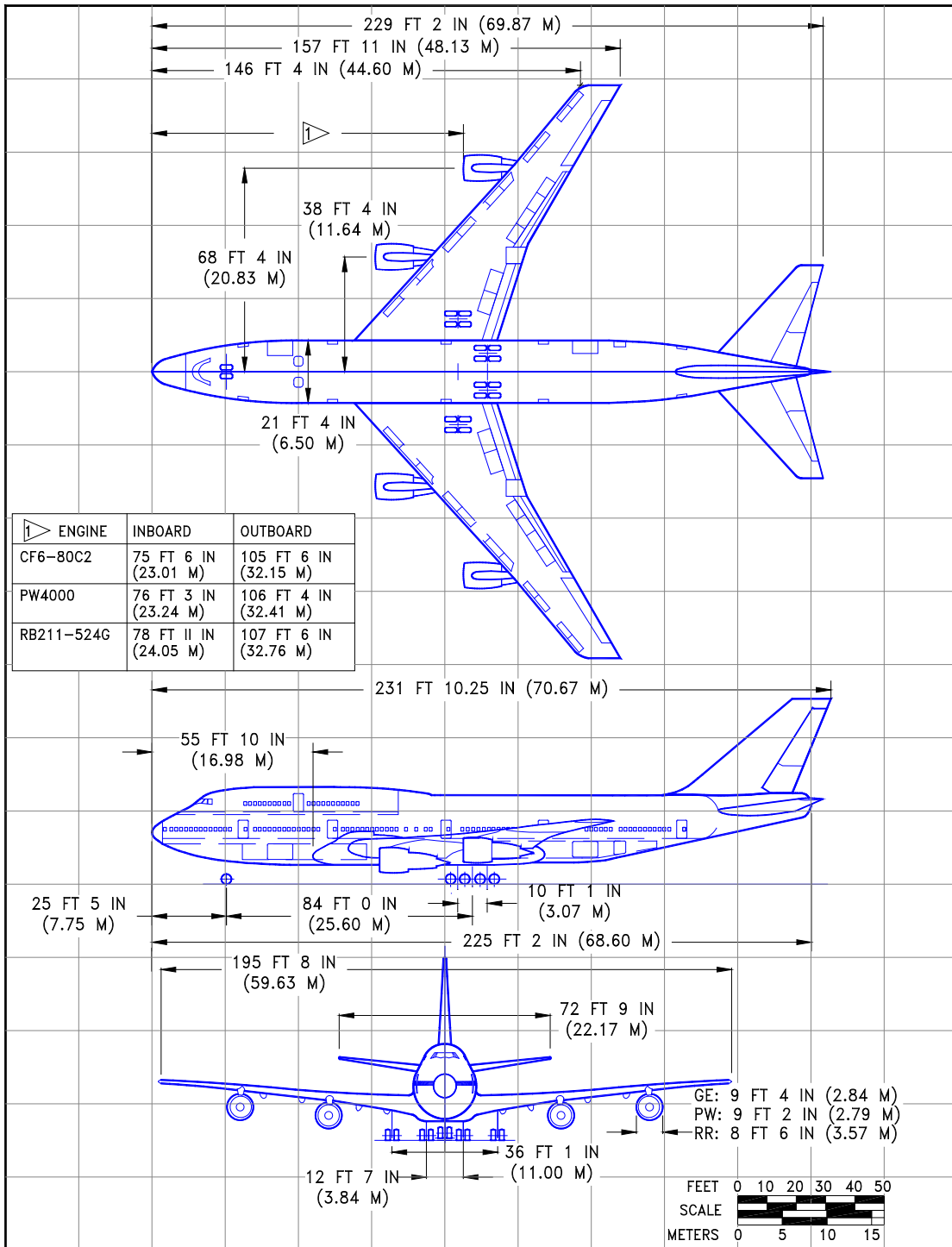

D6-58326-1

2.3 GROUND CLEARANCES

2.3.1 Ground Clearances: Model 747-400, -400 Combi

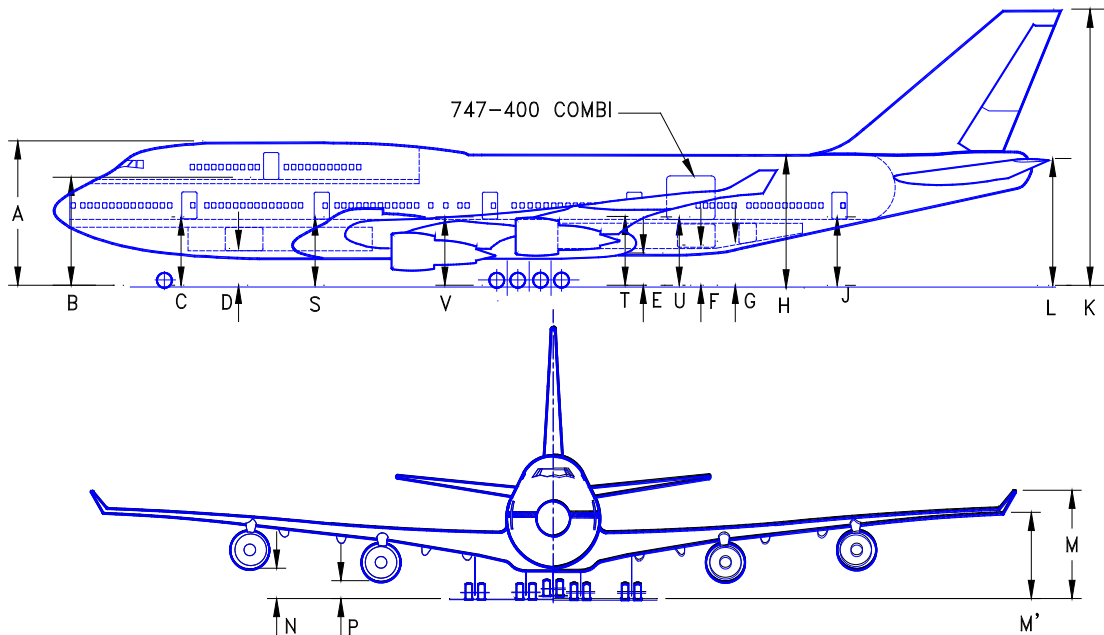

Dimension	MINIMUM		MAXIMUM	
	FT - IN	M	FT - IN	M
A	32 - 1	9.80	33 - 6	10.23
B	24 - 8	7.53	25 - 11	7.91
C	15 - 6	4.74	16 - 11	5.18
D	8 - 10	2.71	10 - 2	3.11
E	6 - 10	2.09	7 - 11	2.42
F	9 - 3	2.82	10 - 5	3.18
G	9 - 10	3.00	11 - 2	3.41
H	29 - 7	9.02	31 - 4	9.56
J	15 - 9	4.82	17 - 5	5.33
K	61 - 7	18.80	64 - 0	19.51
L	27 - 6	8.39	29 - 9	9.09
M	22 - 0	6.71	24 - 0	7.32
M'	16 - 9	5.11	18 - 9	5.71
N	4 - 4	1.32	5 - 10	1.80
P	2 - 3	0.71	3 - 0	0.93
S	15 - 9	4.80	16 - 10	5.15
T	16 - 0	4.88	17 - 0	5.19
U	16 - 0	4.88	17 - 3	5.28
V	15 - 11	4.87	16 - 9	5.11

NOTES:

- VERTICAL CLEARANCES SHOWN OCCUR DURING MAXIMUM VARIATIONS OF AIRPLANE ATTITUDE. COMBINATIONS OF AIRPLANE LOADING AND UNLOADING ACTIVITIES THAT PRODUCE THE GREATEST POSSIBLE VARIATIONS IN ATTITUDE WERE USED TO ESTABLISH THE VARIATIONS SHOWN.
- DURING ROUTINE SERVICING, THE AIRPLANE REMAINS RELATIVELY STABLE, PITCH AND ELEVATION CHANGES OCCURRING SLOWLY.

D6-58326-1

REV E

September 2023

2-17

2.3.2 Ground Clearances: Model 747-400ER

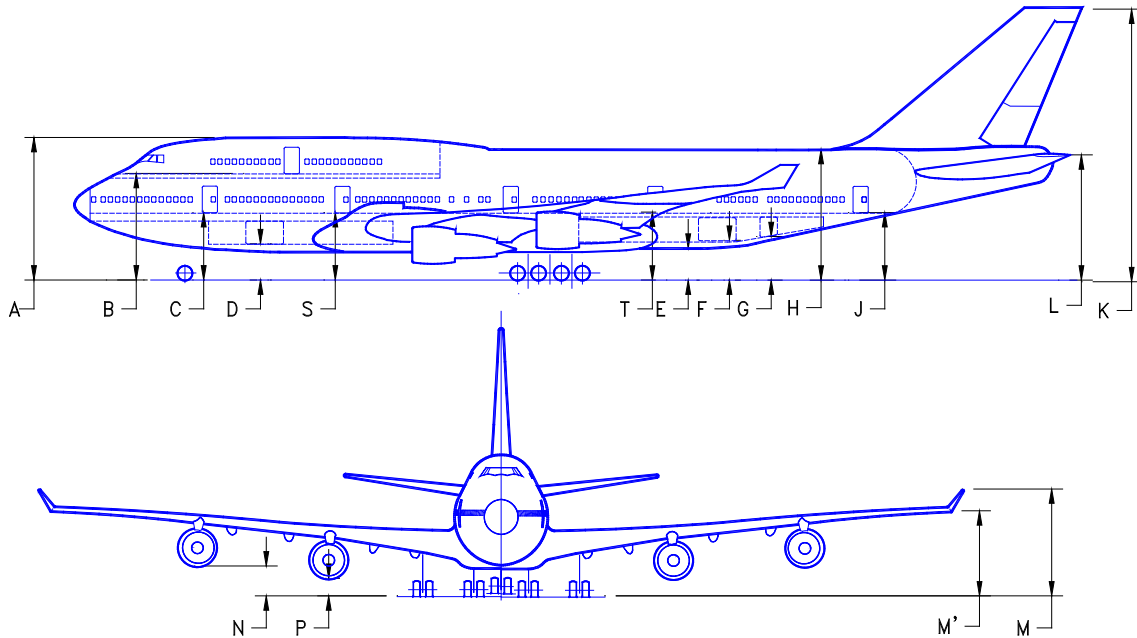

Dimension	MINIMUM		MAXIMUM	
	FT - IN	M	FT - IN	M
A	32 - 3	9.82	33 - 7	10.25
B	24 - 9	7.55	26 - 1	7.94
C	15 - 7	4.75	17 - 1	5.20
D	8 - 11	2.73	10 - 3	3.13
E	7 - 1	2.16	8 - 1	2.47
F	9 - 6	2.9	10 - 7	3.23
G	10 - 2	3.11	11 - 5	3.47
H	27 - 9	8.46	31 - 7	9.63
J	16 - 4	4.99	17 - 8	5.40
K	62 - 6	19.06	64 - 3	19.59
L	28 - 4	8.64	30 - 1	9.17
M	22 - 0	6.71	24 - 0	7.32
M'	16 - 9	5.11	18 - 9	5.71
N (PW)	4 - 7	1.40	5 - 10	1.78
N (GE)	4 - 7	1.40	5 - 11	1.80
N (RR)	4 - 4	1.32	5 - 7	1.71
P (PW)	2 - 4	0.71	3 - 0	0.91
P (GE)	2 - 5	0.72	3 - 0	0.91
P (RR)	2 - 4	0.71	3 - 0	0.91
S	15 - 10	4.82	16 - 11	5.16
T	16 - 3	4.95	17 - 2	5.25

NOTES:

1. VERTICAL CLEARANCES SHOWN OCCUR DURING MAXIMUM VARIATIONS OF AIRPLANE ATTITUDE. COMBINATIONS OF AIRPLANE LOADING AND UNLOADING ACTIVITIES THAT PRODUCE THE GREATEST POSSIBLE VARIATIONS IN ATTITUDE WERE USED TO ESTABLISH THE VARIATIONS SHOWN.
2. DURING ROUTINE SERVICING, THE AIRPLANE REMAINS RELATIVELY STABLE, PITCH AND ELEVATION CHANGES OCCURRING SLOWLY.

D6-58326-1

2.3.3 Ground Clearances: Model 747-400 Freighter

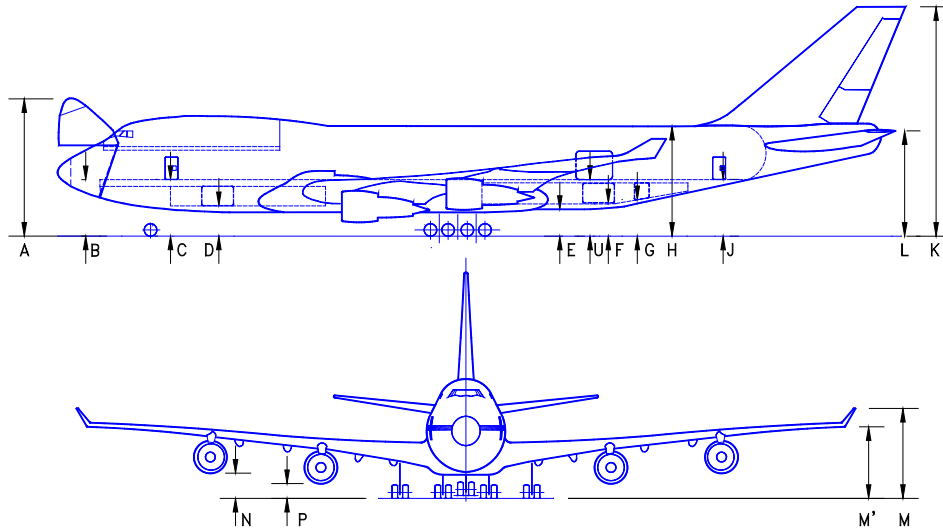

Dimension	MINIMUM		MAXIMUM	
	FT - IN	M	FT - IN	M
A	38 - 2	11.79	40 - 2	12.24
B	15 - 6	4.72	17 - 2	5.23
C	15 - 7	4.74	17 - 8	5.37
D	9 - 0	2.75	10 - 9	3.28
E	7 - 1	2.16	8 - 1	2.47
F	9 - 6	2.89	10 - 7	3.23
G	10 - 2	3.10	11 - 4	3.46
H	27 - 9	8.46	31 - 7	9.63
J	16 - 3	4.97	17 - 8	5.38
K	61 - 11	18.87	64 - 1	19.54
L	27 - 9	8.47	29 - 11	9.12
M	22 - 0	6.71	24 - 0	7.32
M'	16 - 9	5.11	18 - 9	5.71
N (PW)	4 - 7	1.40	5 - 10	1.78
N (GE)	4 - 7	1.40	5 - 11	1.80
N (RR)	4 - 4	1.32	5 - 7	1.71
P (PW)	2 - 4	0.71	3 - 0	0.91
P (GE)	2 - 5	0.72	3 - 0	0.91
P (RR)	2 - 4	0.71	3 - 0	0.91
U	16 - 3	4.97	17 - 5	5.31

NOTES:

1. VERTICAL CLEARANCES SHOWN OCCUR DURING MAXIMUM VARIATIONS OF AIRPLANE ATTITUDE. COMBINATIONS OF AIRPLANE LOADING AND UNLOADING ACTIVITIES THAT PRODUCE THE GREATEST POSSIBLE VARIATIONS IN ATTITUDE WERE USED TO ESTABLISH THE VARIATIONS SHOWN.
2. DURING ROUTINE SERVICING, THE AIRPLANE REMAINS RELATIVELY STABLE, PITCH AND ELEVATION CHANGES OCCURRING SLOWLY.
3. AT MAJOR TERMINALS, A GSE TETHERING DEVICE SHOULD BE USED TO MAINTAIN STABILITY BETWEEN THE MAIN DECK DOOR SILL AND THE LOADING DOCK. CARGO BRIDGE ATTACHMENT FITTINGS LOCATED ON THE NOSE DOOR SILL AT THE FORWARD EDGE OF THE MAIN CARGO DOOR DECK SHOULD BE USED FOR NOSE DOOR SILL STABILIZATION.

D6-58326-1

2.3.4 Ground Clearances: Model 747-400ER Freighter

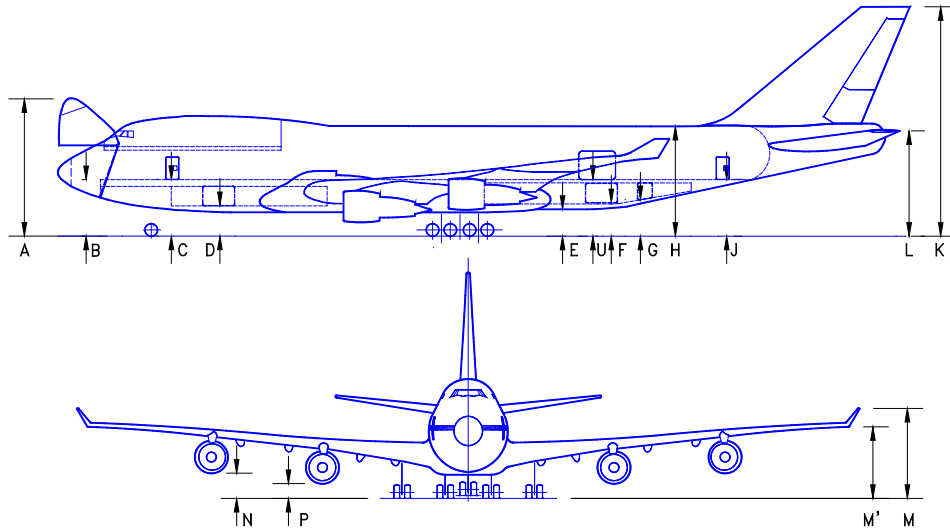

Dimension	MINIMUM		MAXIMUM	
	FT - IN	M	FT - IN	M
A	38 - 2	11.79	40 - 2	12.24
B	15 - 6	4.72	17 - 2	5.23
C	15 - 7	4.74	17 - 8	5.37
D	9 - 0	2.75	10 - 9	3.28
E	7 - 1	2.16	8 - 1	2.47
F	9 - 6	2.89	10 - 7	3.23
G	10 - 2	3.10	11 - 4	3.46
H	27 - 9	8.46	31 - 7	9.63
J	16 - 3	4.97	17 - 8	5.38
K	61 - 11	18.87	64 - 1	19.54
L	27 - 9	8.47	29 - 11	9.12
M	22 - 0	6.71	24 - 0	7.32
M'	16 - 9	5.11	18 - 9	5.71
N (PW)	4 - 7	1.40	5 - 10	1.78
N (GE)	4 - 7	1.40	5 - 11	1.80
N (RR)	4 - 4	1.32	5 - 7	1.71
P (PW)	2 - 4	0.71	3 - 0	0.91
P (GE)	2 - 5	0.72	3 - 0	0.91
P (RR)	2 - 4	0.71	3 - 0	0.91
U	16 - 3	4.97	17 - 5	5.31

NOTES:

1. VERTICAL CLEARANCES SHOWN OCCUR DURING MAXIMUM VARIATIONS OF AIRPLANE ATTITUDE. COMBINATIONS OF AIRPLANE LOADING AND UNLOADING ACTIVITIES THAT PRODUCE THE GREATEST POSSIBLE VARIATIONS IN ATTITUDE WERE USED TO ESTABLISH THE VARIATIONS SHOWN.
2. DURING ROUTINE SERVICING, THE AIRPLANE REMAINS RELATIVELY STABLE, PITCH AND ELEVATION CHANGES SLOWLY.
3. AT MAJOR TERMINALS, A GSE TETHERING DEVICE JULY BE USED TO MAINTAIN STABILITY BETWEEN THE MAIN DECK DOOR SILL AND THE LOADING DOCK. CARGO BRIDGE ATTACHMENT FITTINGS LOCATED ON THE NOSE DOOR SILL AT THE FORWARD EDGE OF THE MAIN CARGO DOOR DECK JULY BE USED FOR NOSE DOOR SILL STABILIZATION.

2.3.5 Ground Clearances: Model 747-400 Domestic

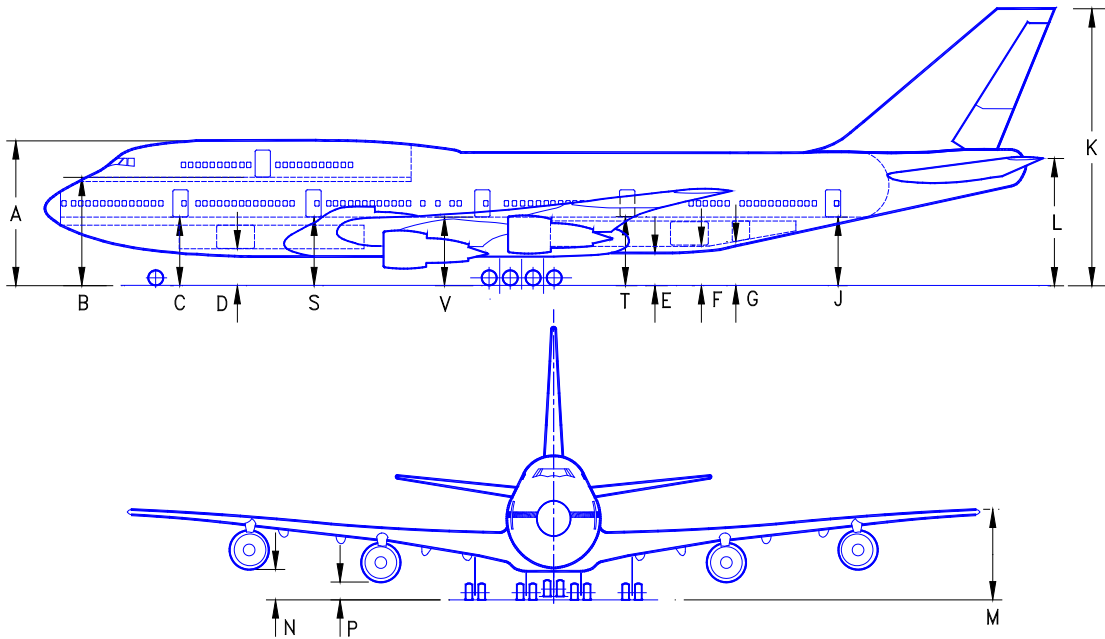

Dimension	MINIMUM		MAXIMUM	
	FT - IN	M	FT - IN	M
A	31 - 10	9.70	34 - 1	10.39
B	24 - 10	7.57	27 - 5	8.36
C	15 - 3	4.65	17 - 7	5.36
D	8 - 8	2.64	10 - 8	3.25
E	6 - 3	1.91	6 - 9	2.06
F	8 - 10	2.69	10 - 4	3.15
G	9 - 6	2.90	11 - 4	3.45
H	28 - 6	8.69	31 - 0	9.45
J	15 - 0	4.57	17 - 6	5.33
K	60 - 2	18.34	64 - 3	19.58
L	27 - 0	8.23	30 - 8	9.35
M	17 - 7	5.36	19 - 2	5.84
N	6 - 0	1.83	7 - 0	2.13
P	3 - 9	1.14	4 - 6	1.37
S	15 - 8	4.78	17 - 2	5.23
T	15 - 8	4.78	16 - 7	5.05

NOTES:

1. VERTICAL CLEARANCES SHOWN OCCUR DURING MAXIMUM VARIATIONS OF AIRPLANE ATTITUDE. COMBINATIONS OF AIRPLANE LOADING AND UNLOADING ACTIVITIES THAT PRODUCE THE GREATEST POSSIBLE VARIATIONS IN ATTITUDE WERE USED TO ESTABLISH THE VARIATIONS SHOWN.
2. DURING ROUTINE SERVICING, THE AIRPLANE REMAINS RELATIVELY STABLE, PITCH AND ELEVATION CHANGES OCCURRING SLOWLY.

2.4 INTERIOR ARRANGEMENTS

2.4.1 Typical Interior Arrangements: Model 747-400, Tri-Class Configuration

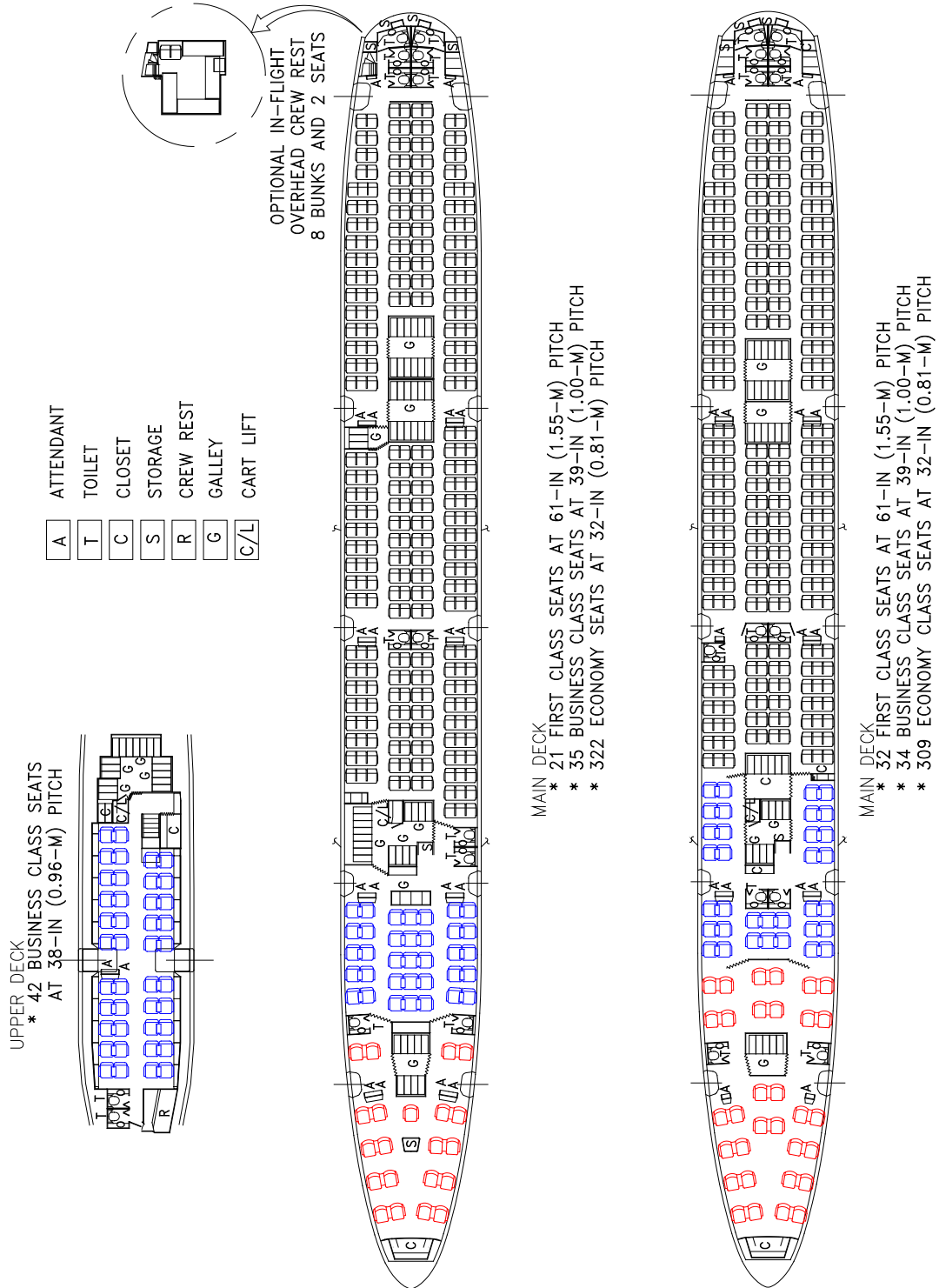

2.4.2 Typical Interior Arrangements: Model 747-400ER, Tri-Class Configuration

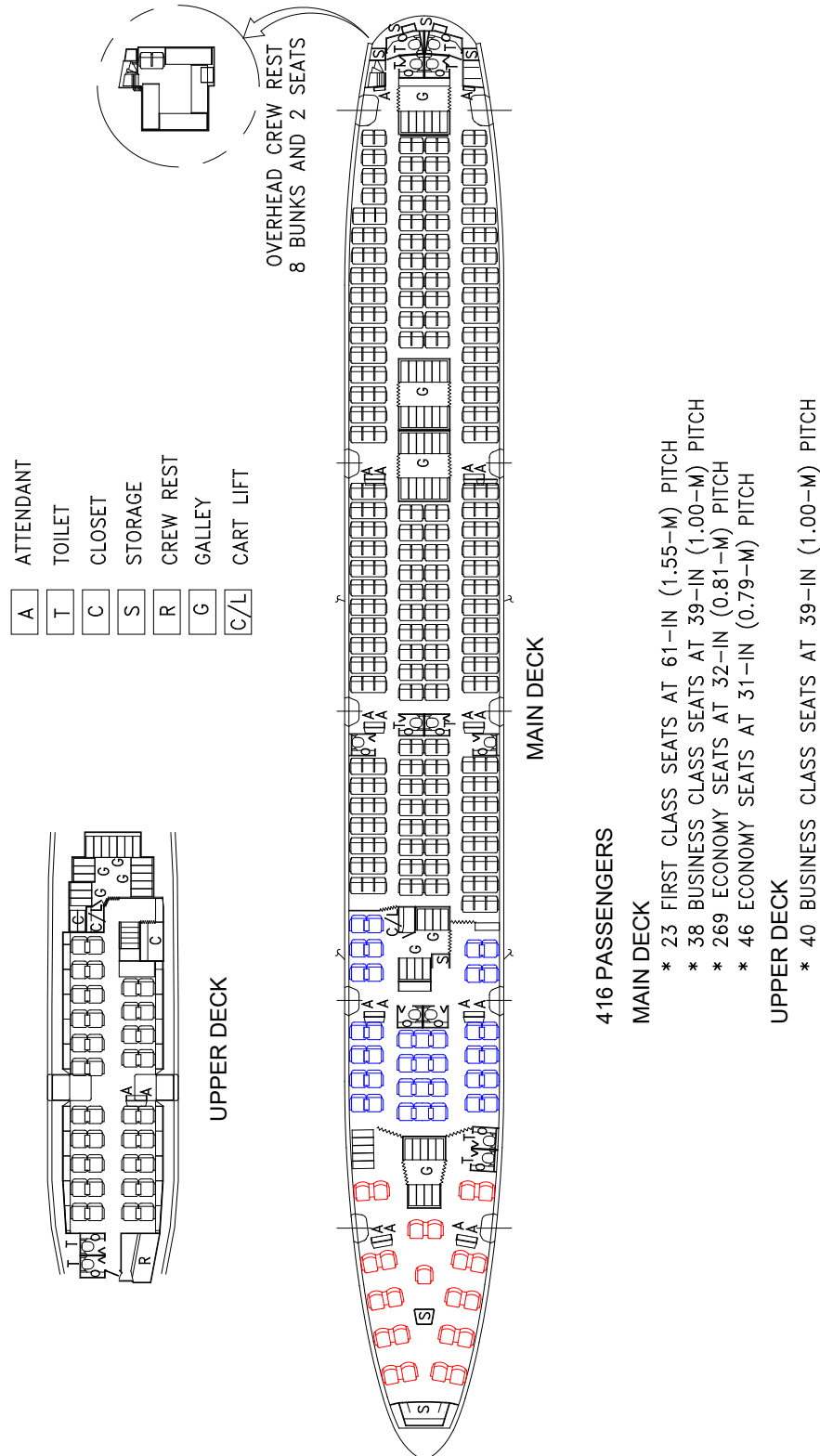

D6-58326-1

2.4.3 Typical Interior Arrangements: Model 747-400ER, Dual Class Configuration

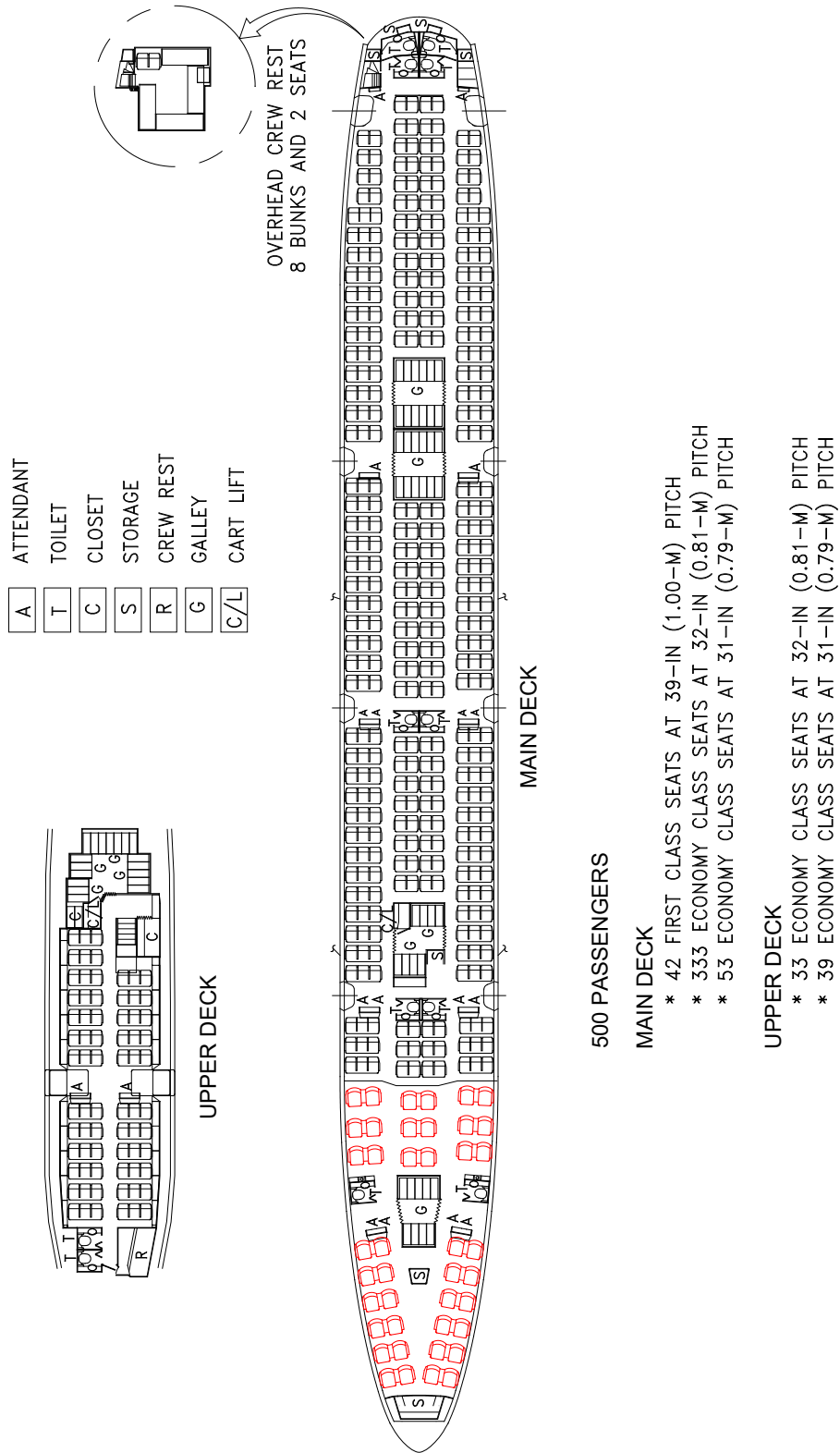

D6-58326-1

2.4.4 Typical Interior Arrangements: Model 747-400 Combi, Passenger/Cargo Configuration

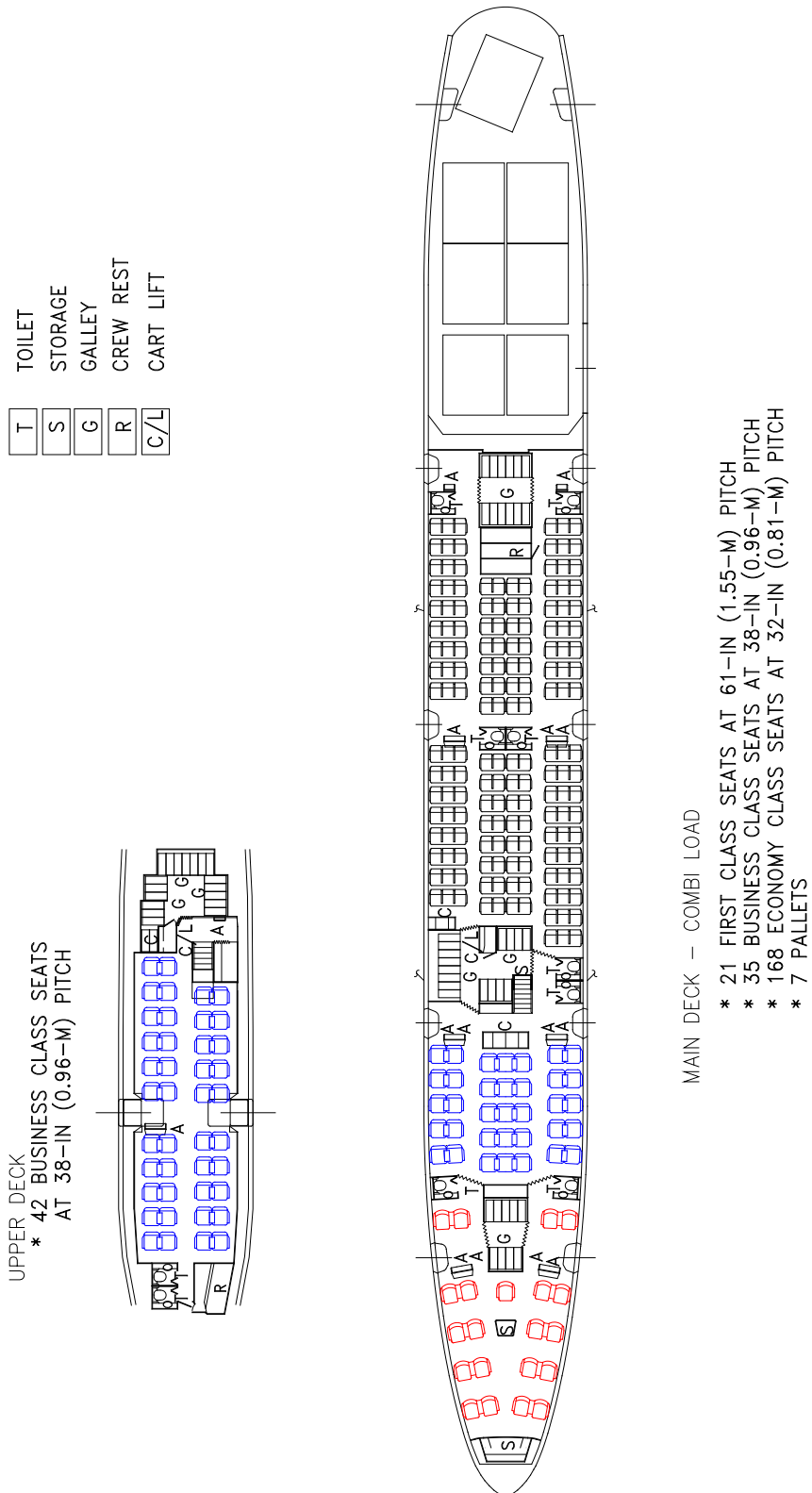

2.4.5 Typical Interior Arrangements: Model 747-400 Freighter, -400ER Freighter, Main Deck Cargo

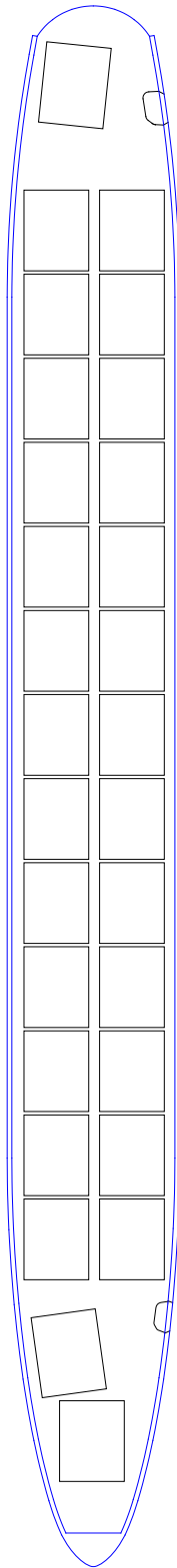

* 29 10-FT (3-M) CONTAINERS

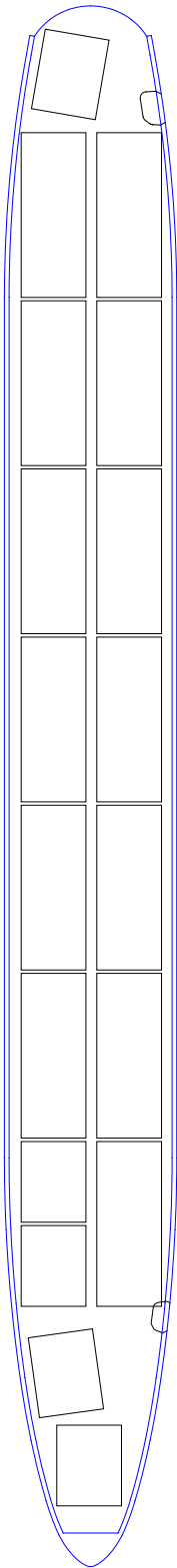

* 13 20-FT (6-M) CONTAINERS
* 5 10-FT (3-M) CONTAINERS

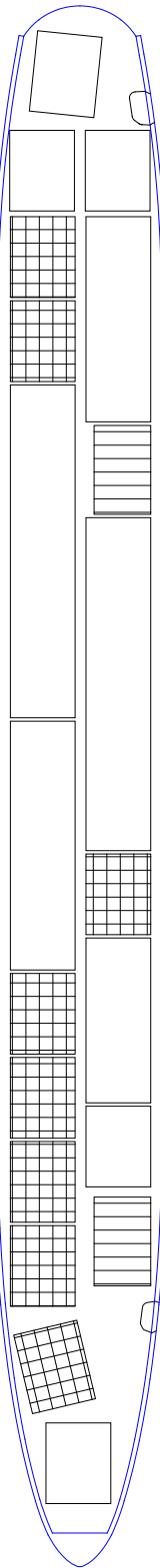

* RANDOM MIX OF CARGO PALLETS
AND CONTAINERS UP TO 40 FT (12 M)

2.4.6 Typical Interior Arrangements: Model 747-400 Domestic, High-Density Seating Configuration

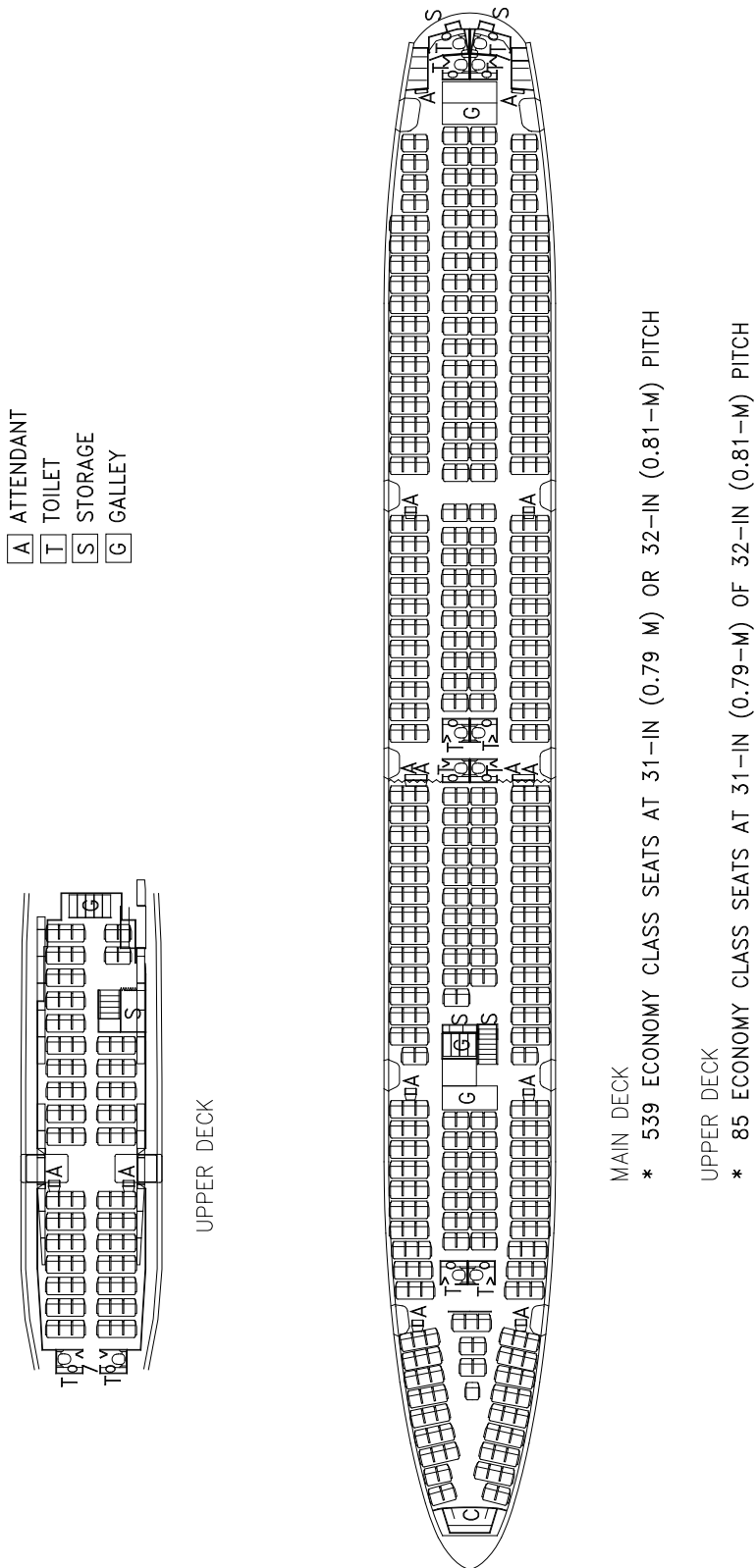

D6-58326-1

2.5 CABIN CROSS SECTIONS

2.5.1 Cabin Cross-Sections: Model 747-400, First and Business Class Seats

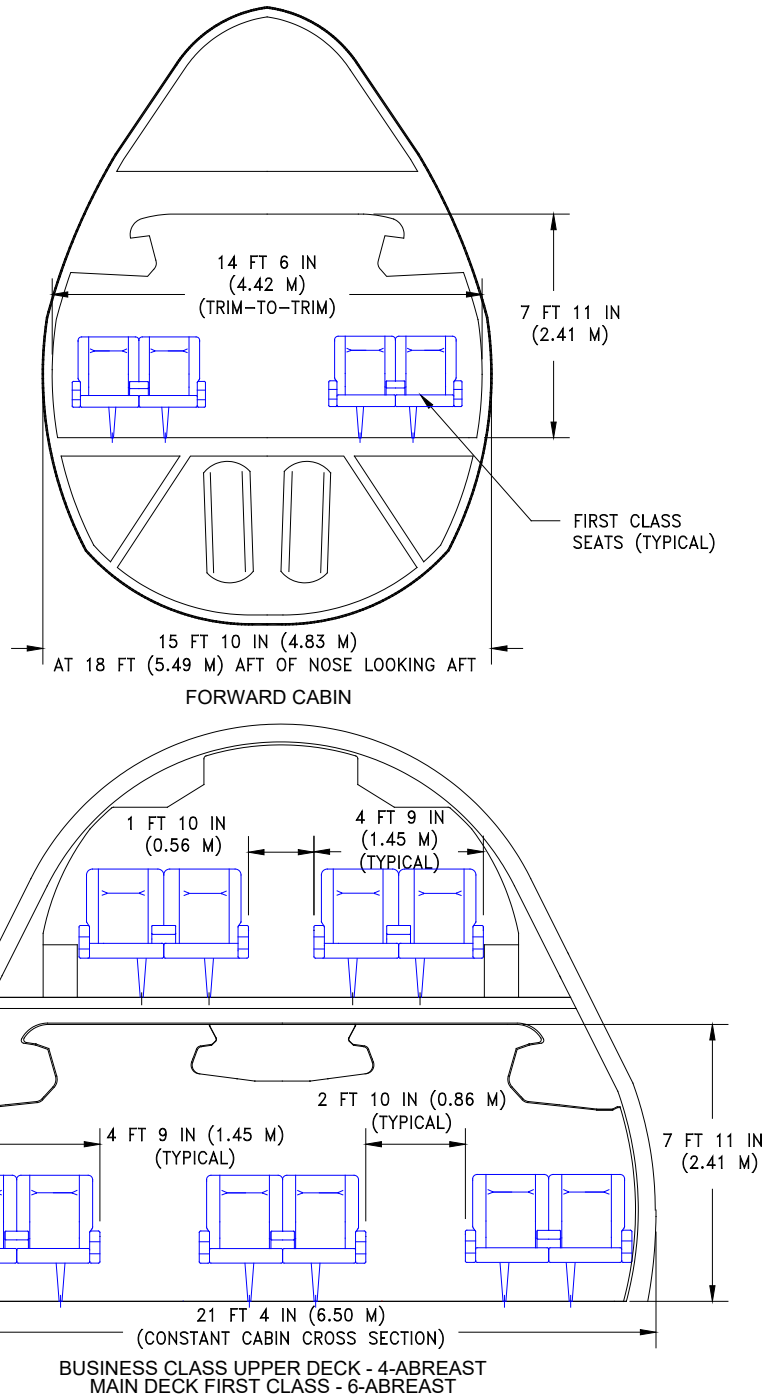

D6-58326-1

REV E

September 2023

2-28

2.5.2 Cabin Cross-Sections: Model 747-400, Business Class Seats

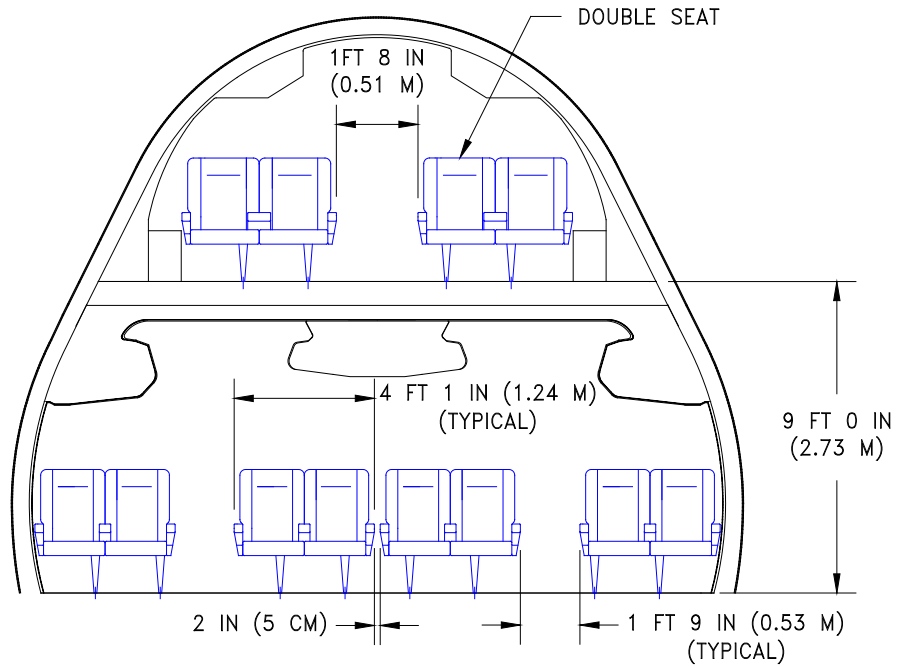

UPPER DECK - 4-ABREAST
 MAIN DECK - 8-ABREAST

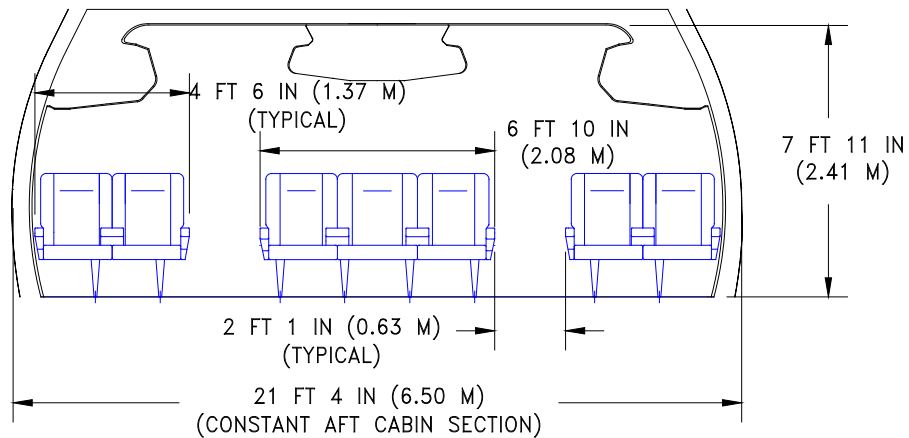

MAIN DECK - 7-ABREAST

2.5.3 Cabin Cross-Sections: Model 747-400, Economy Class Seats

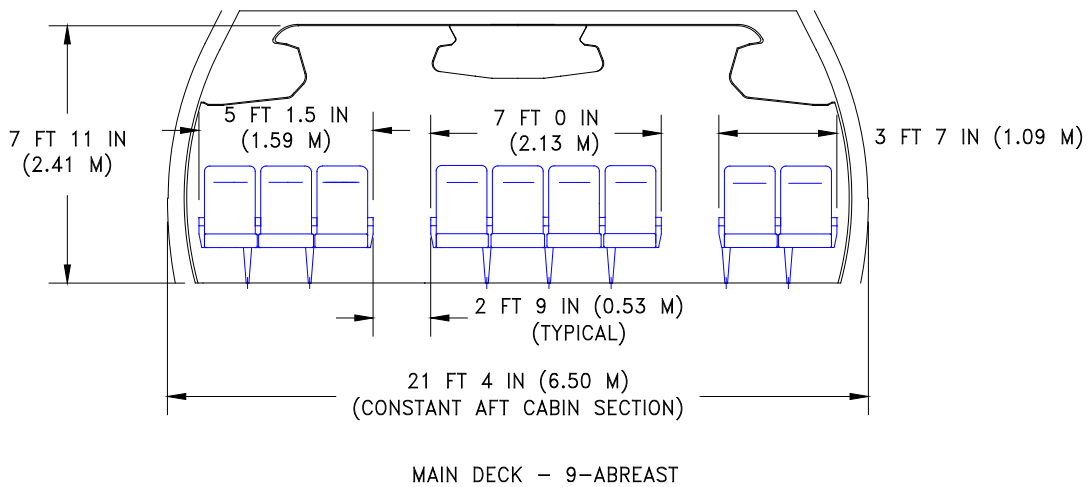
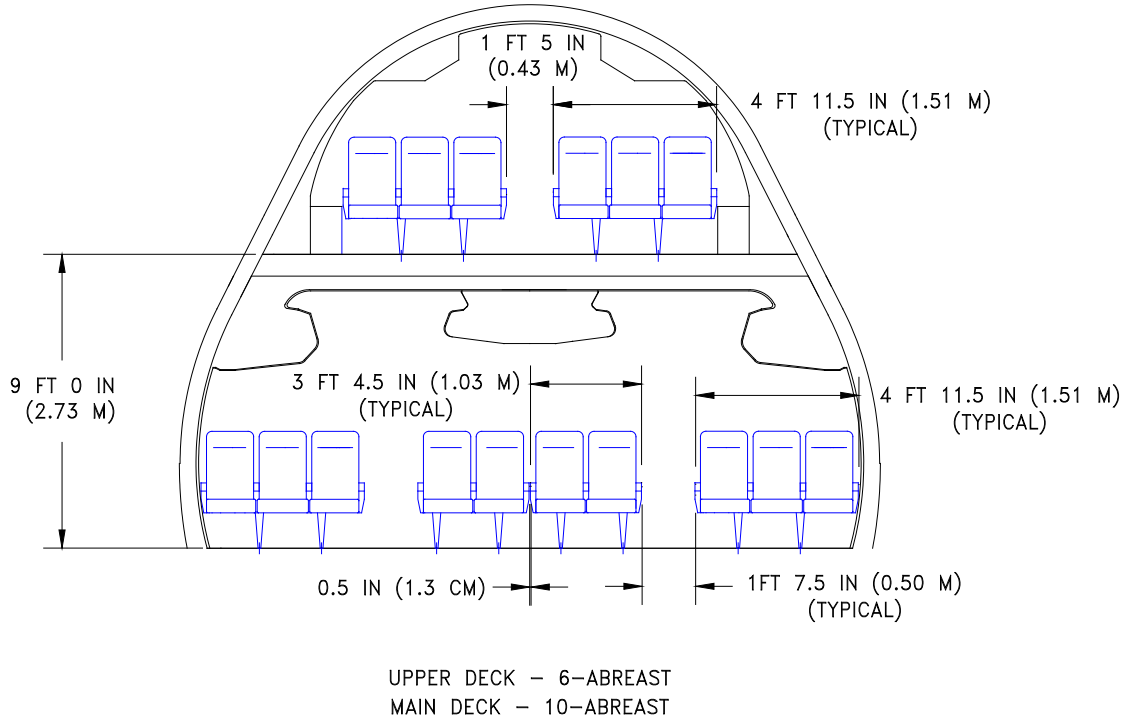

D6-58326-1

2.5.4 Cabin Cross-Sections: Model 747-400, Galley and Stairs

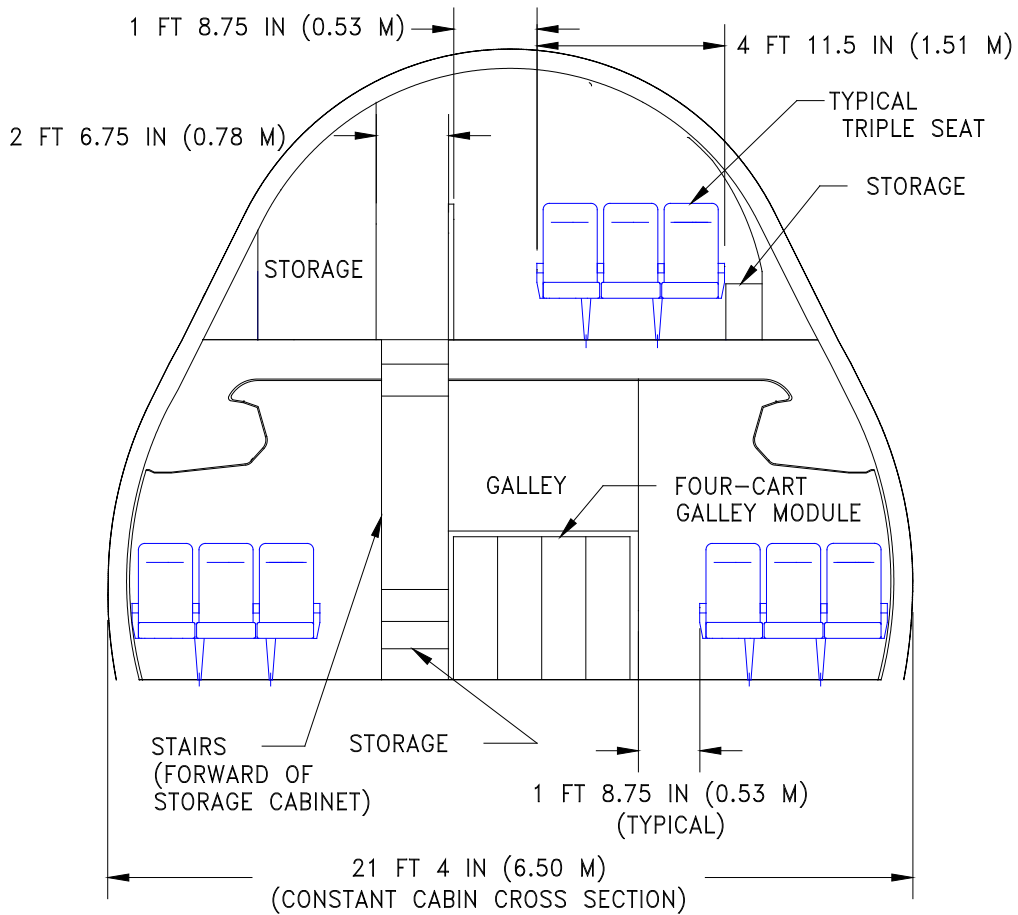

**SECTION THROUGH STAIRS
(VIEW LOOKING FORWARD)**

2.6 LOWER CARGO COMPARTMENTS

2.6.1 Lower Cargo Compartments: Model 747-400, -400 Combi, -400 Domestic, Containers and Bulk Cargo

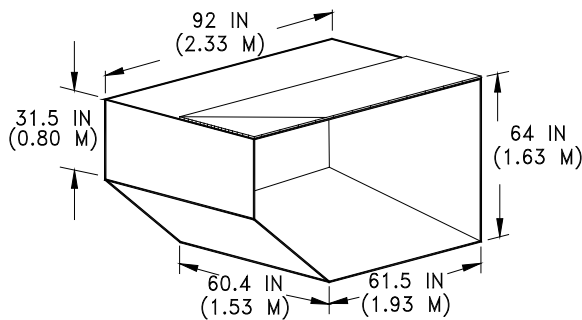
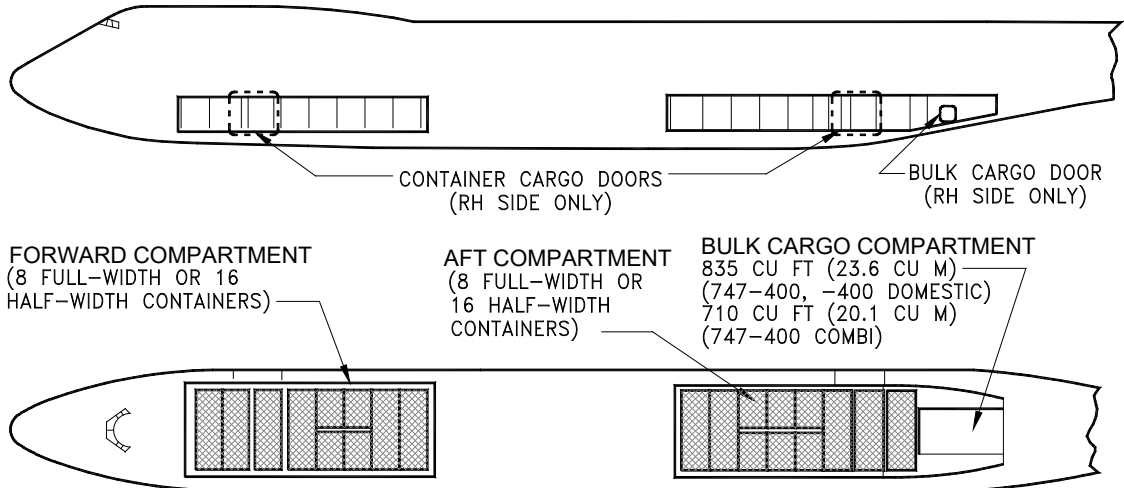

HALF-WIDTH CONTAINER (LD1)

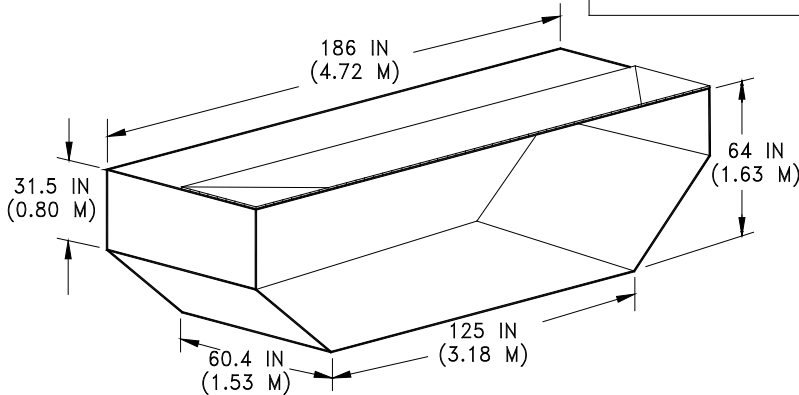

FULL-WIDTH CONTAINER (LD2)

CONTAINER DATA		
	HALF-WIDTH	FULL-WIDTH
INTERNAL VOLUME PER CONTAINER	173 CU FT 4.9 CU M	350 CU FT 9.9 CU M
TARE WEIGHT	270 LB 123 KG	470 LB 213 KG
MAXIMUM CARGO WEIGHT PER CONTAINER	3,230 LB 1,467 KG	6,530 LB 2,965 KG
MAXIMUM GROSS WEIGHT PER CONTAINER	3,500 LB 1,590 KG	7,000 LB 3,180 KG
TOTAL VOLUME OF 16 FULL-WIDTH CONTAINERS IS 5,600 CU FT (158.6 CU M)		
GROSS WEIGHT FOR 16 FULL-WIDTH OR 32 HALF-WIDTH CONTAINERS IS 112,000 LB (50,802 KG)		

NOTES:

1. CONTAINER WEIGHT AND DATA ARE TYPICAL. CONSULT USING AIRLINE FOR SPECIFIC DATA.
2. OPTIONS ARE OFFERED FOR CARRIAGE OF CERTAIN STANDARD MILITARY AND COMMERCIAL PALLETS IN CONTAINER COMPARTMENTS.

D6-58326-1

REV E

September 2023

2-32

2.6.2 Lower Cargo Compartments: Model 747-400ER, Containers and Bulk Cargo

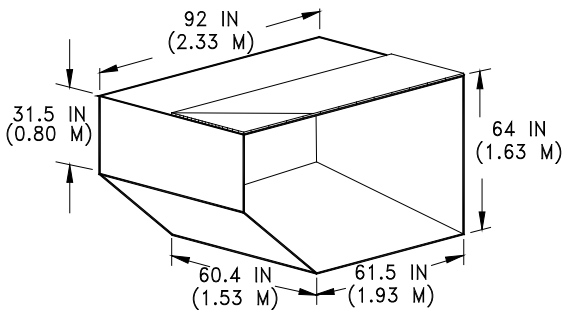
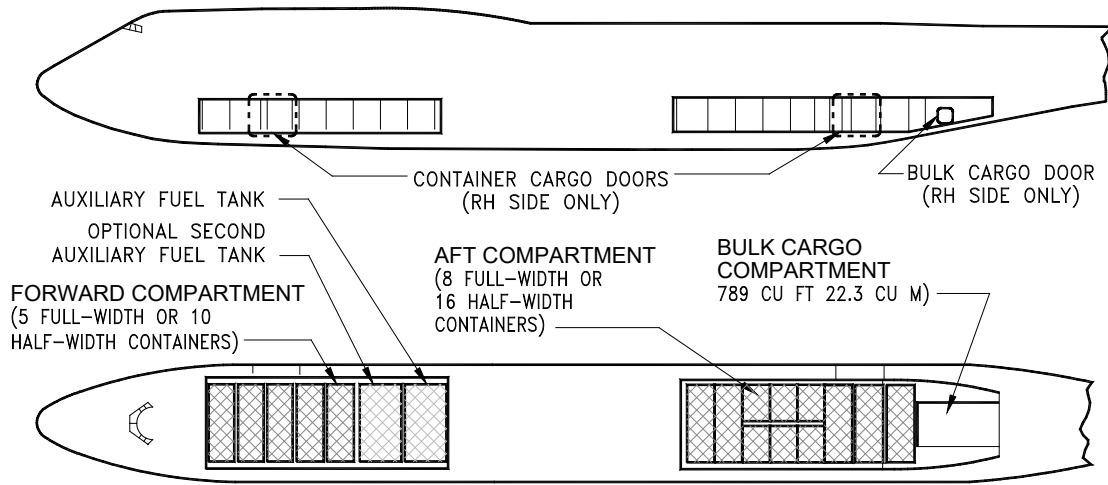

HALF-WIDTH CONTAINER (LD1)

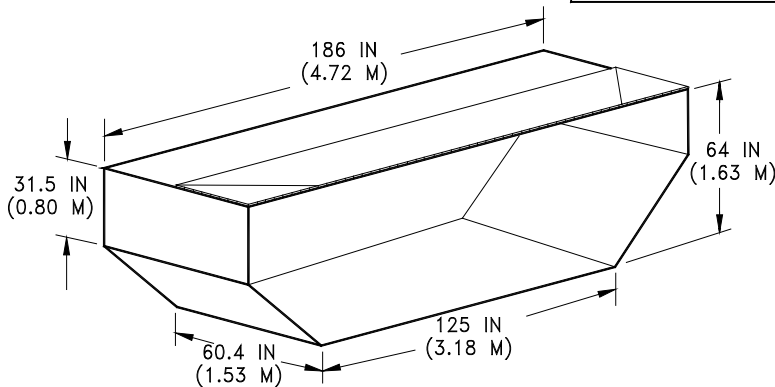

FULL-WIDTH CONTAINER (LD2)

CONTAINER DATA		
CONTAINER DATA	HALF-WIDTH	FULL-WIDTH
INTERNAL VOLUME PER CONTAINER	173 CU FT 4.9 CU M	350 CU FT 9.9 CU M
TARE WEIGHT	270 LB 123 KG	470 LB 213 KG
MAXIMUM CARGO WEIGHT PER CONTAINER	3,230 LB 1,467 KG	6,530 LB 2,965 KG
MAXIMUM GROSS WEIGHT PER CONTAINER	3,500 LB 1,590 KG	7,000 LB 3,180 KG
TOTAL VOLUME OF 13 FULL-WIDTH CONTAINERS IS 4,550 CU FT (128.8 CU M)		
GROSS WEIGHT FOR 13 FULL-WIDTH OR 26 HALF-WIDTH CONTAINERS IS 91,000 LB (35,872 KG)		

NOTES:

1. CONTAINER WEIGHT AND DATA ARE TYPICAL. CONSULT USING AIRLINE FOR SPECIFIC DATA.
2. OPTIONS ARE OFFERED FOR CARRIAGE OF CERTAIN STANDARD MILITARY AND COMMERCIAL PALLETS IN CONTAINER COMPARTMENTS.

2.6.3 Lower Cargo Compartments: Model 747-400 Freighter, -400ER Freighter, Containers and Bulk Cargo

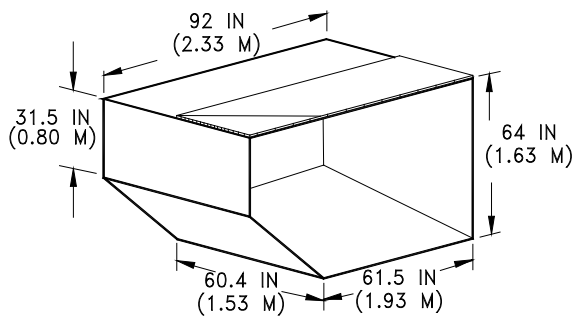
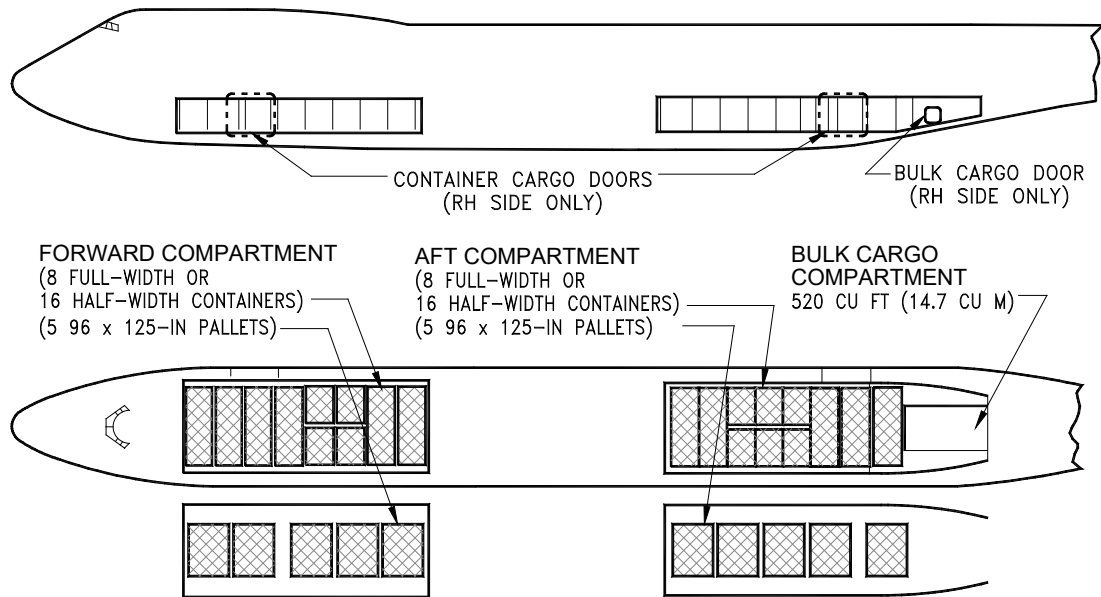

HALF-WIDTH CONTAINER (LD1)

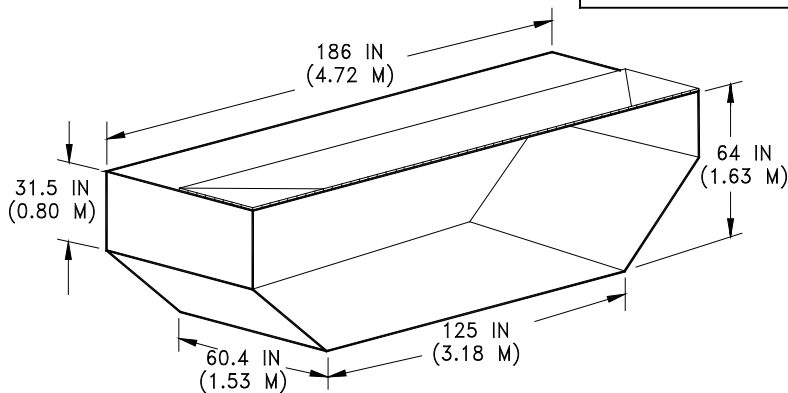

FULL-WIDTH CONTAINER (LD2)

CONTAINER DATA		
CONTAINER DATA	HALF-WIDTH	FULL-WIDTH
INTERNAL VOLUME PER CONTAINER	173 CU FT 4.9 CU M	350 CU FT 9.9 CU M
TARE WEIGHT	270 LB 123 KG	470 LB 213 KG
MAXIMUM CARGO WEIGHT PER CONTAINER	3,230 LB 1,467 KG	6,530 LB 2,965 KG
MAXIMUM GROSS WEIGHT PER CONTAINER	3,500 LB 1,590 KG	7,000 LB 3,180 KG
TOTAL VOLUME OF 16 FULL-WIDTH CONTAINERS IS 5,600 CU FT (158.6 CU M)		
GROSS WEIGHT FOR 16 FULL-WIDTH OR 32 HALF-WIDTH CONTAINERS IS 112,000 LB (50,802 KG)		

NOTES:

1. CONTAINER WEIGHT AND DATA ARE TYPICAL. CONSULT USING AIRLINE FOR SPECIFIC DATA.
2. OPTIONS ARE OFFERED FOR CARRIAGE OF CERTAIN STANDARD MILITARY AND COMMERCIAL PALLETS IN CONTAINER COMPARTMENTS.

2.7 DOOR CLEARANCES

2.7.1 Door Locations: Model 747-400, Main Deck Passenger and Cargo Doors

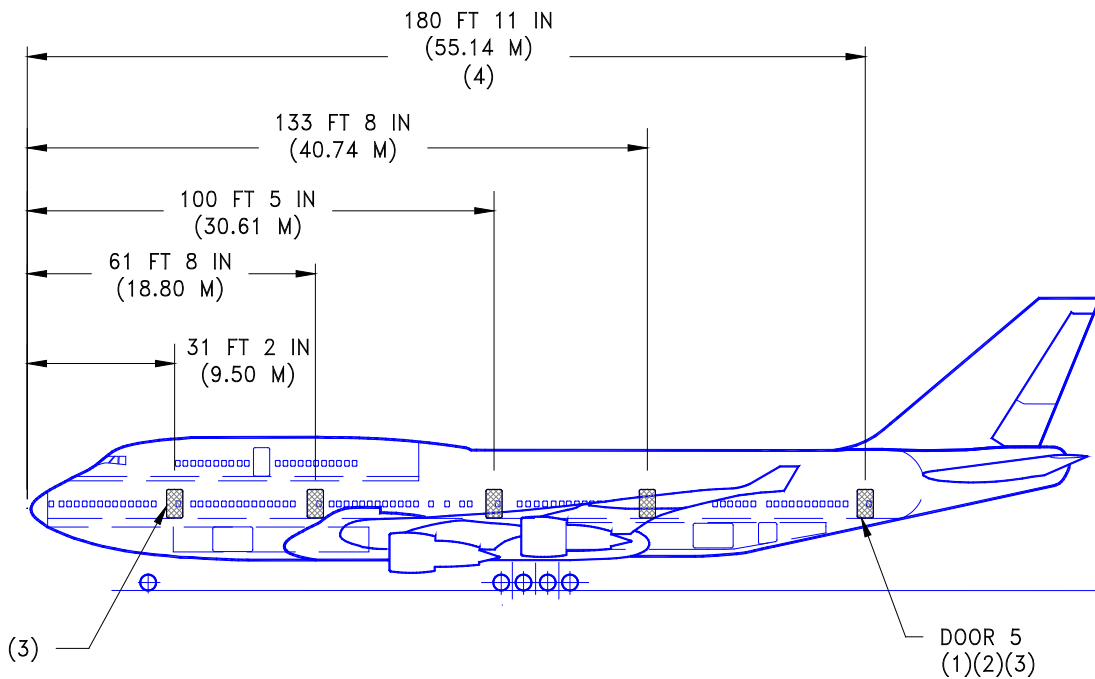

NOTES:

- (1) 10 PASSENGER DOORS – 5 EACH SIDE
DOOR OPENING SIZE = 42 BY 76 IN (1.07 BY 1.93 M)
OVERALL DOOR SIZE = 47 BY 76 IN (1.19 BY 1.93 M)
- (2) SEE SECTION 2.3 FOR DOOR SILL HEIGHTS
- (3) LH DOOR NO. 1 AND NO. 5 ON 747-400 FREIGHTER, -400ER FREIGHTER
- (4) 180 FT 5 IN (55.00 M) ON 747-400 FREIGHTER, -400ER FREIGHTER

2.7.2 Door Clearances: Model 747-400, Main Deck Entry and Service Doors 1-4 (Plan View)

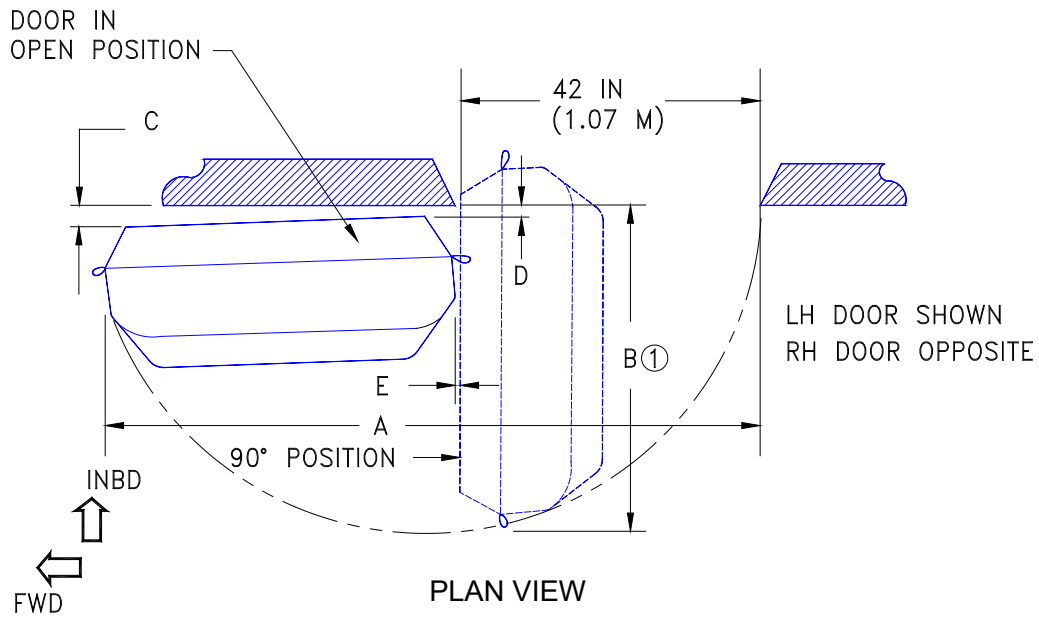

	DOOR NUMBER			
	1 ②	2	3	4
A	7 FT 6 IN	7 FT 6 IN	7 FT 6 IN	7 FT 6 IN
	2.29 M	2.29 M	2.29 M	2.29 M
B ①	3 FT 9 IN	3 FT 10 IN	3 FT 10 IN	3 FT 10 IN
	1.14 M	1.17 M	1.17 M	1.17 M
C	4 IN	3 IN	3 IN	3 IN
	0.102 M	0.076 M	0.076 M	0.076 M
D	1 IN	1 IN	1 IN	1 IN
	0.025 M	0.025 M	0.025 M	0.025 M
E	1 IN	1 IN	1 IN	1 IN
	0.025 M	0.025 M	0.025 M	0.025 M

① MEASURED AT DOOR OPENING CENTERLINE AT DOOR SILL LEVEL AT 90° FROM AIRPLANE CENTERLINE.

② LH SIDE ONLY ON 747-400 FREIGHTER, -400ER FREIGHTER.

D6-58326-1

2.7.3 Door Clearances: Model 747-400, Main Deck Entry and Service Doors 1-4 (View Looking Forward)

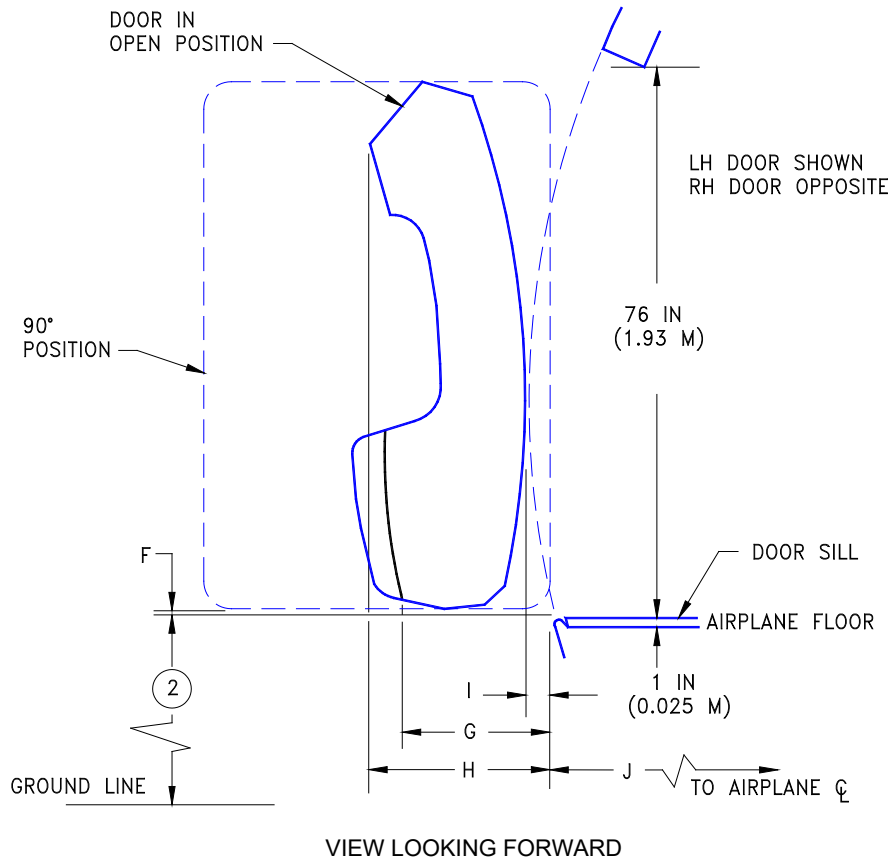

	DOOR NUMBER			
	1 (3)	2	3	4
F	2 IN (0.05 M)			
G (1)	1 FT 7 IN (0.48 M)	1 FT 10 IN (0.56 M)		
H (1)	1 FT 11 IN (0.58 M)	2 FT (0.61 M)	1 FT 9 IN (0.53 M)	2 FT (0.61 M)
I (1)	1 IN (0.025 M)	3 IN (0.076 M)	0	3 IN (0.076 M)
J (1)	9 FT 6 IN (2.90 M)	10 FT 5 IN (3.18 M)	10 FT 8 IN (3.25 M)	10 FT 5 IN (3.18 M)

(1) MEASURED AT DOOR OPENING CENTERLINE AT DOOR SILL LEVEL AT 90° FROM AIRPLANE CENTERLINE

(2) SEE SEC. 2.3 FOR DOOR SILL HEIGHTS

(3) LH SIDE ONLY ON 747-400 FREIGHTER, -400ER FREIGHTER

D6-58326-1

REV E

September 2023

2-37

2.7.4 Door Clearances: Model 747-400, Main Deck Entry and Service Door 5

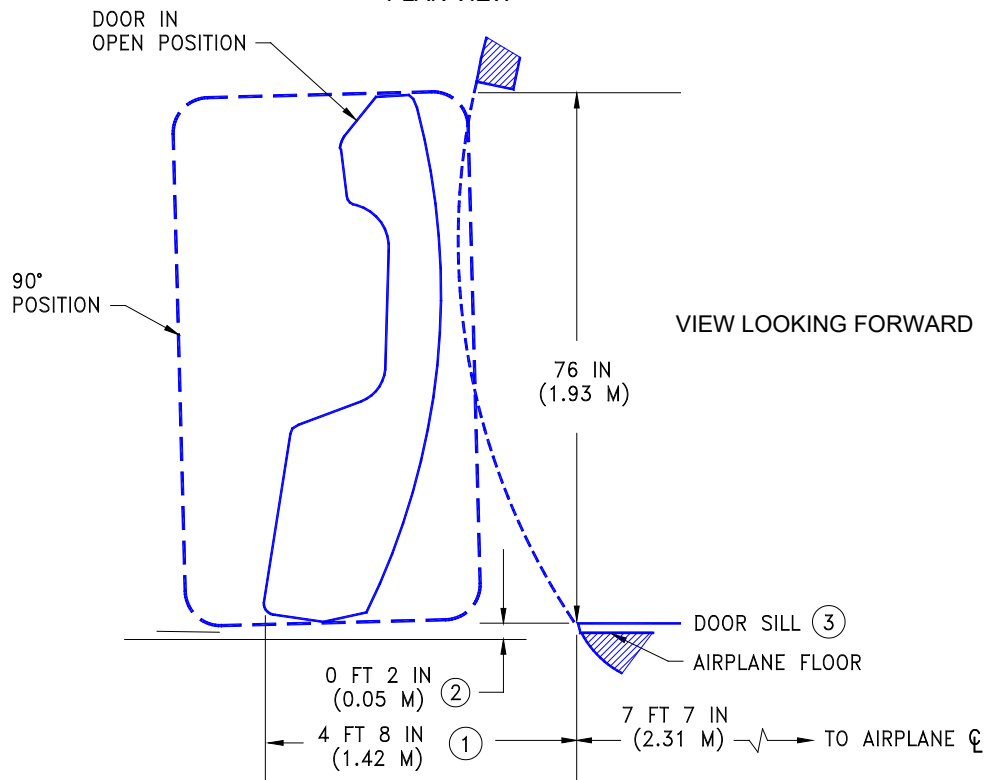
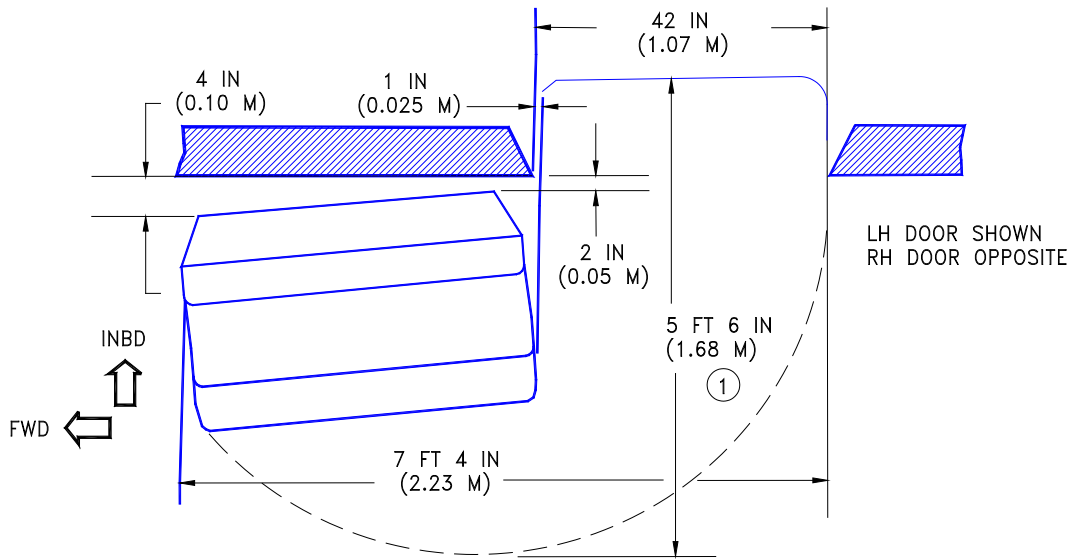

- ① MEASURED AT DOOR OPENING CENTERLINE AT DOOR SILL LEVEL AT 90° FROM AIRPLANE CENTERLINE
- ② DOOR HINGE IS INCLINED 3 DEGREES FROM VERTICAL
- ③ SEE SEC. 2.3 FOR DOOR SILL HEIGHTS
- ④ LH SIDE ONLY ON 747-400 FREIGHTER, -400ER FREIGHTER

D6-58326-1

REV E

September 2023

2-38

2.7.5 Door Clearances: Model 747-400, Upper Deck Emergency Exit Door

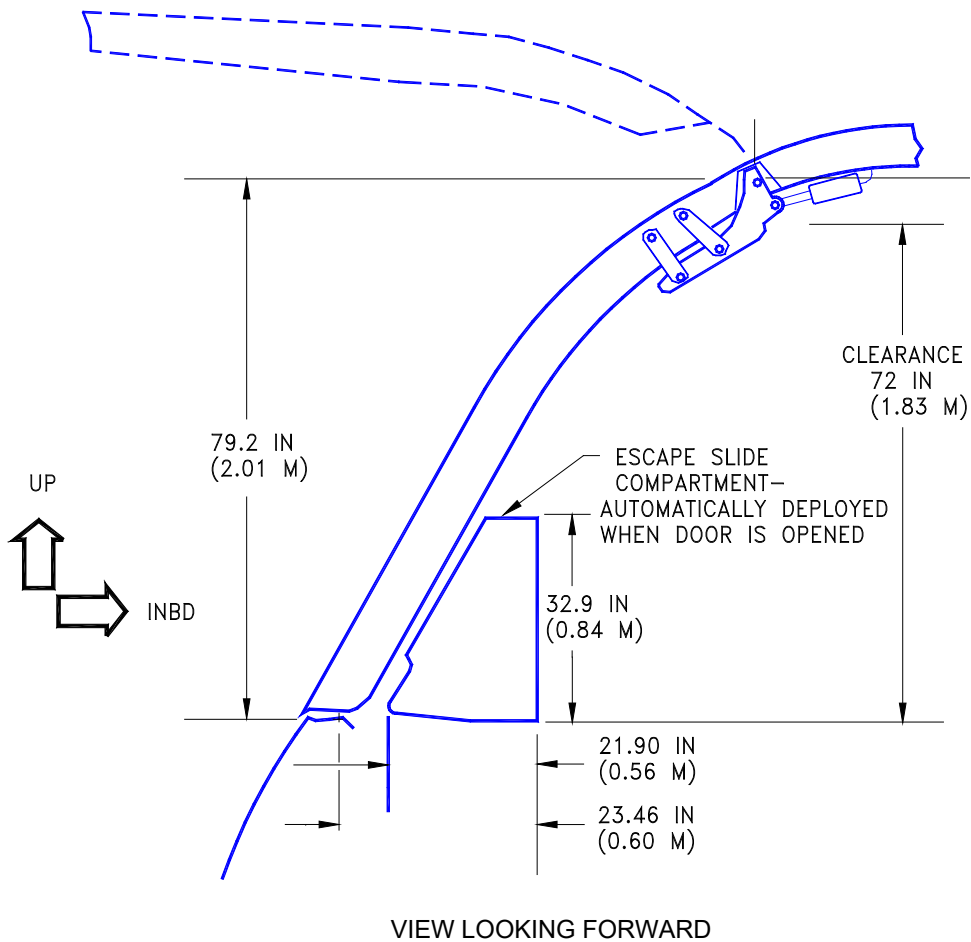
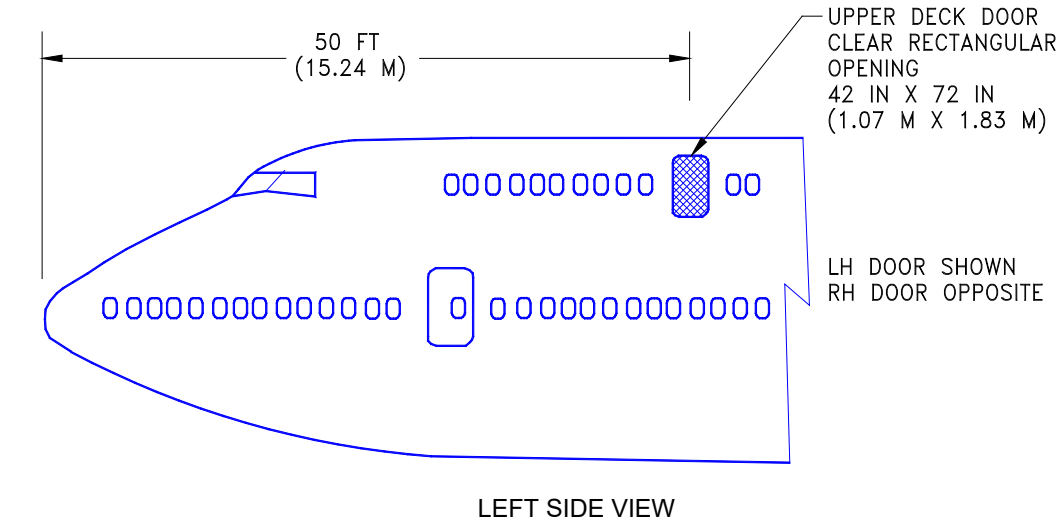

D6-58326-1

REV E

September 2023

2-39

2.7.6 Door Clearances: Model 747-400, Lower Deck Cargo Door (Forward)

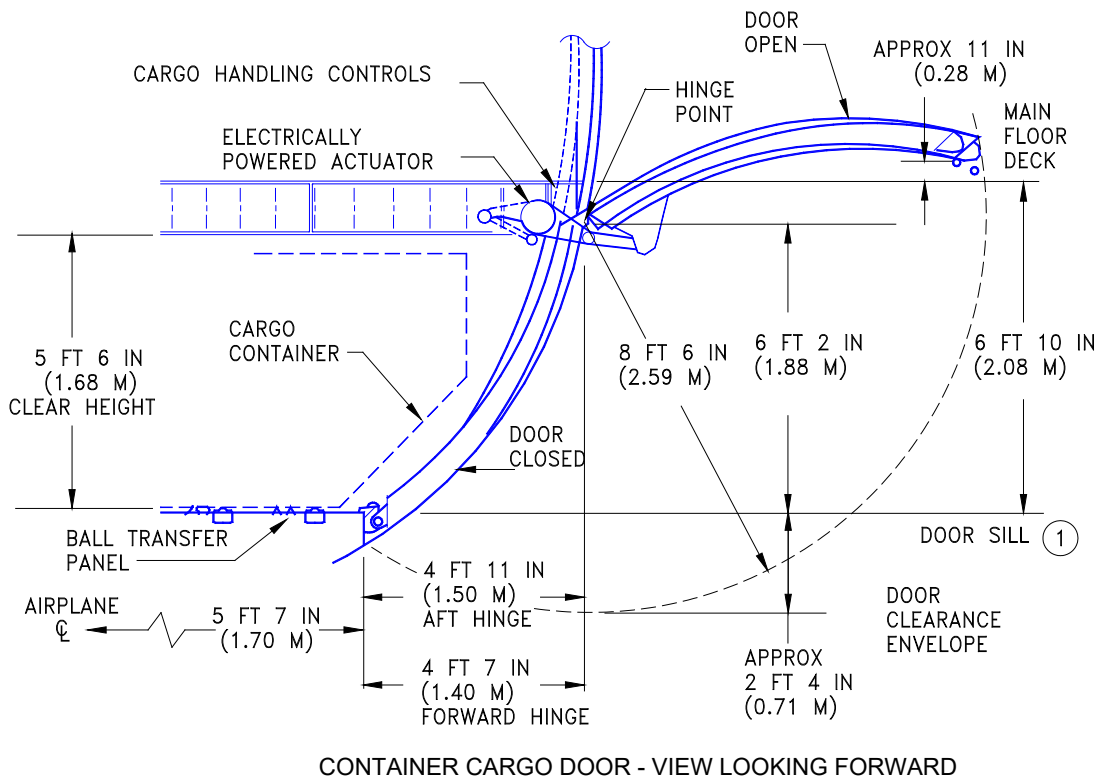
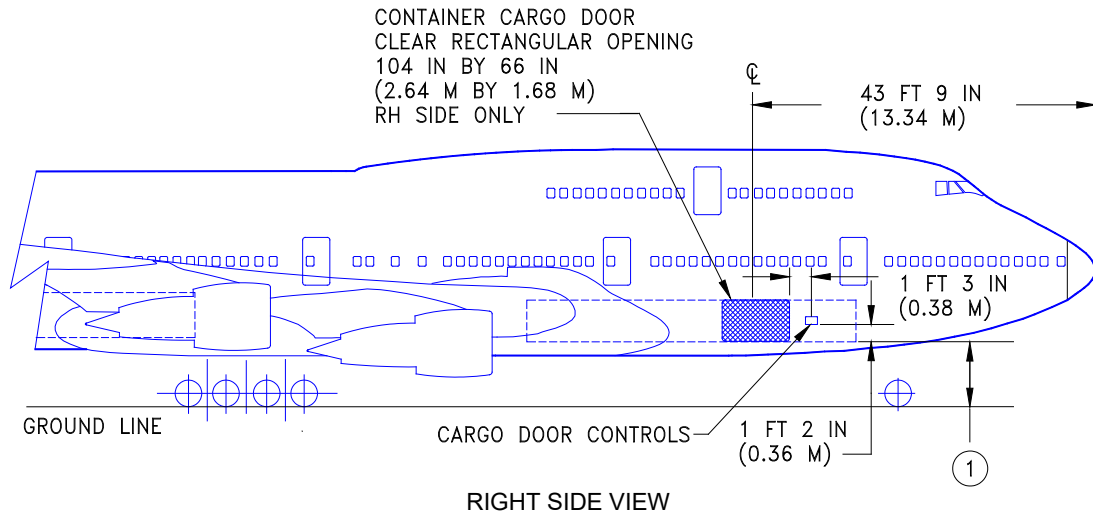

D6-58326-1

2.7.7 Door Clearances: Model 747-400, Lower Deck Cargo Door (Aft)

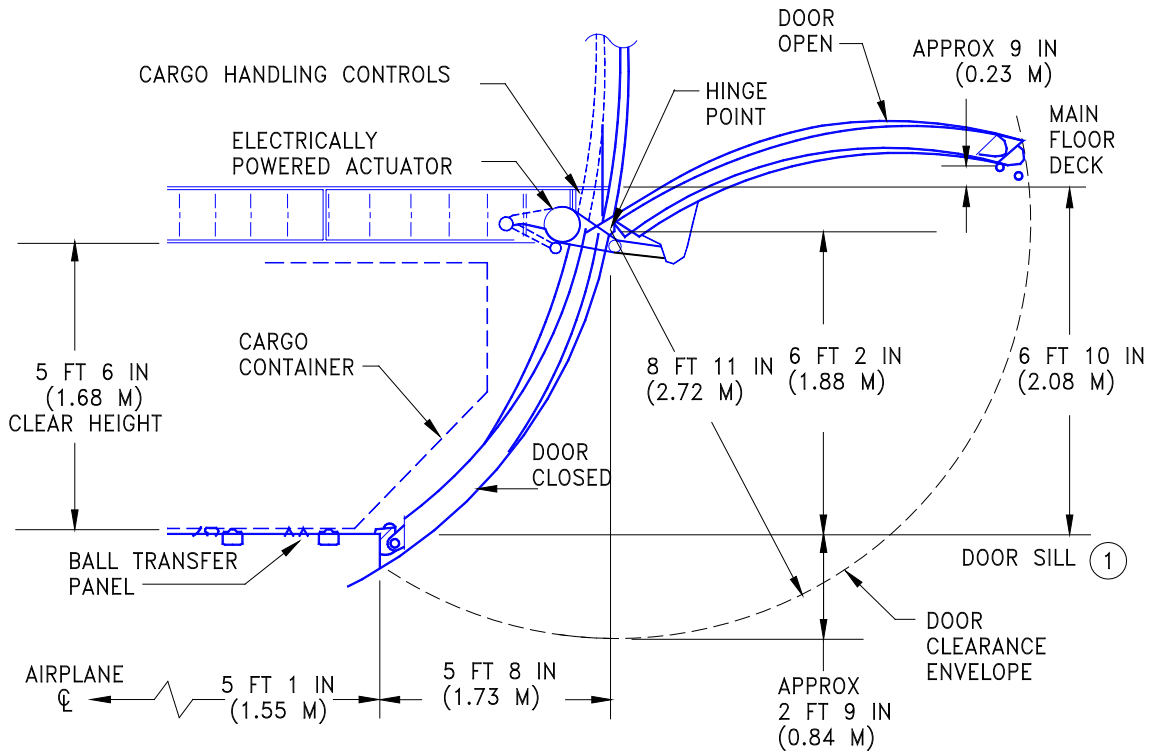
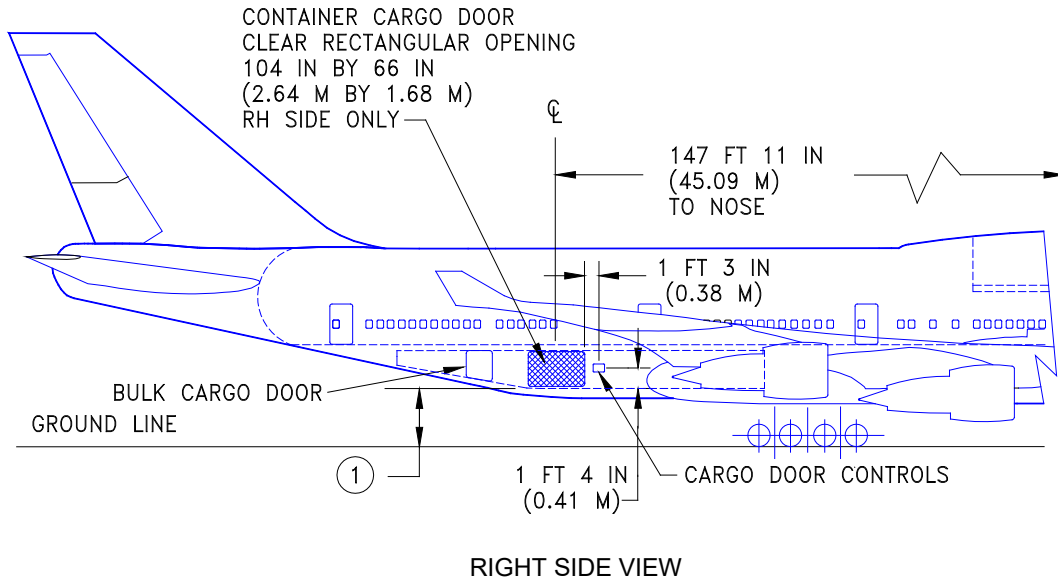

CONTAINER CARGO DOOR - VIEW LOOKING FORWARD

① SEE SECTION 2.3 FOR DOOR SILL HEIGHTS

D6-58326-1

2.7.8 Door Clearances: Model 747-400, Bulk Cargo Door

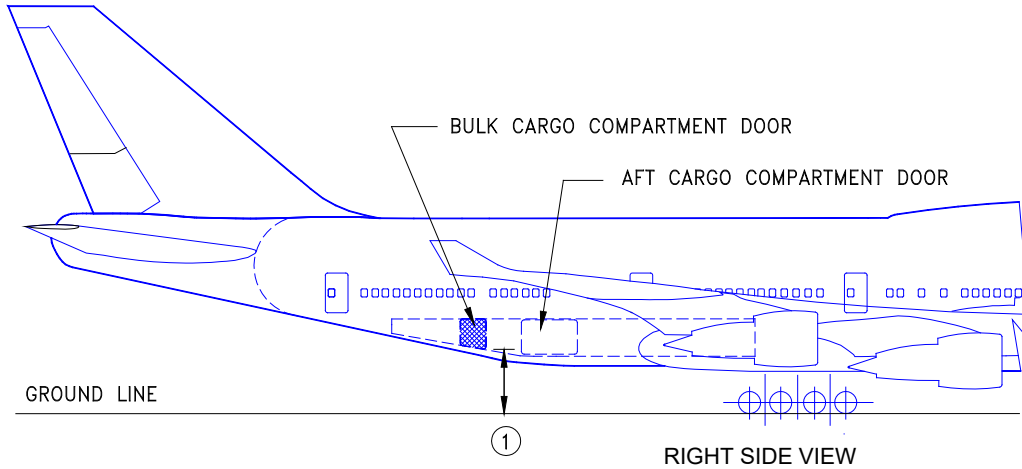

① SEE SECTION 2.3 FOR DOOR SILL HEIGHTS

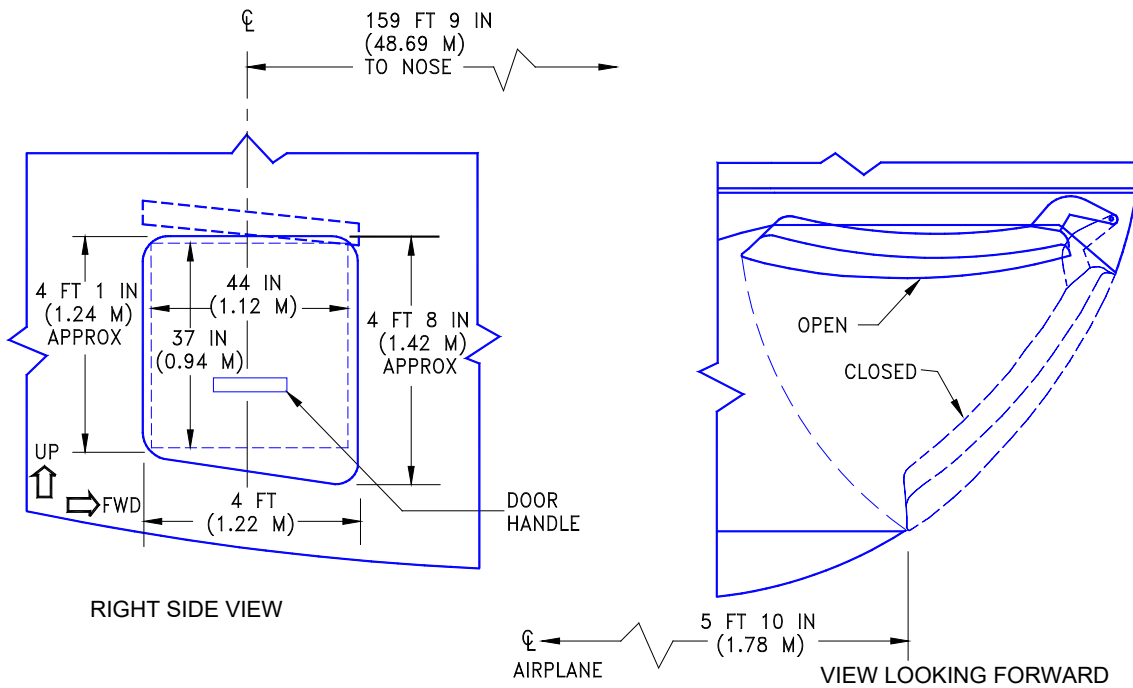

D6-58326-1

2.7.9 Door Clearances: Model 747-400 Combi, -400 Freighter, -400ER Freighter, Main Deck Cargo Door

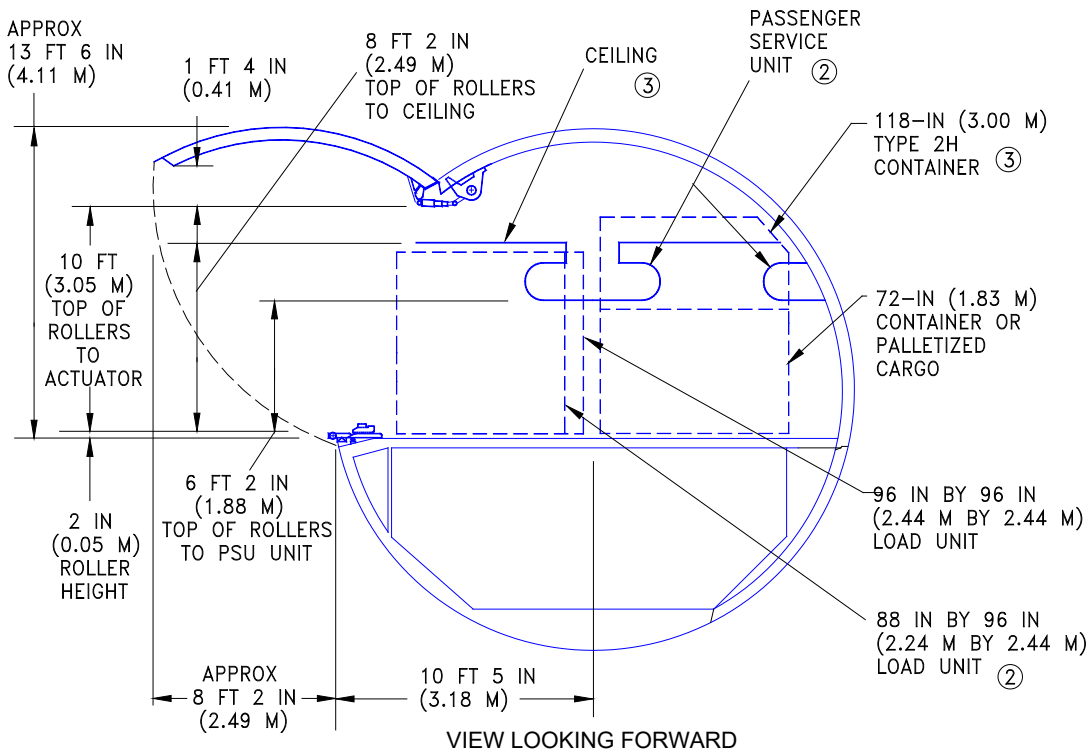
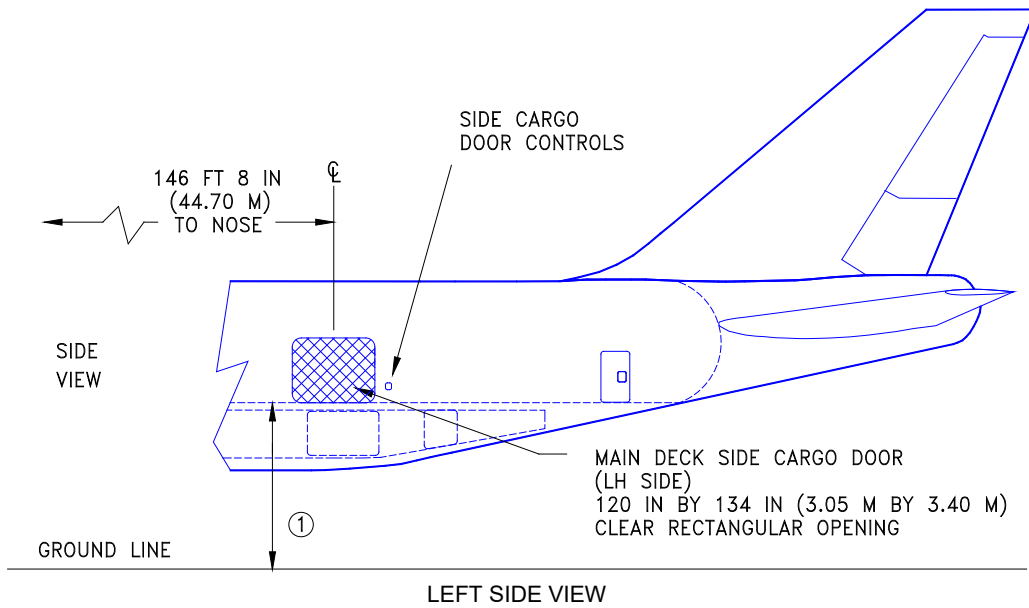

- ① SEE SECTION 2.3 FOR DOOR SILL HEIGHTS
- ② PSU'S ARE REMOVED WHEN 96-IN HIGH CONTAINER OR PALLET IS LOADED
- ③ CEILING IS REMOVED WHEN TYPE 2H CONTAINER IS LOADED

D6-58326-1

2.7.10 Door Clearances: Model 747-400 Freighter, -400ER Freighter, Nose Cargo Door

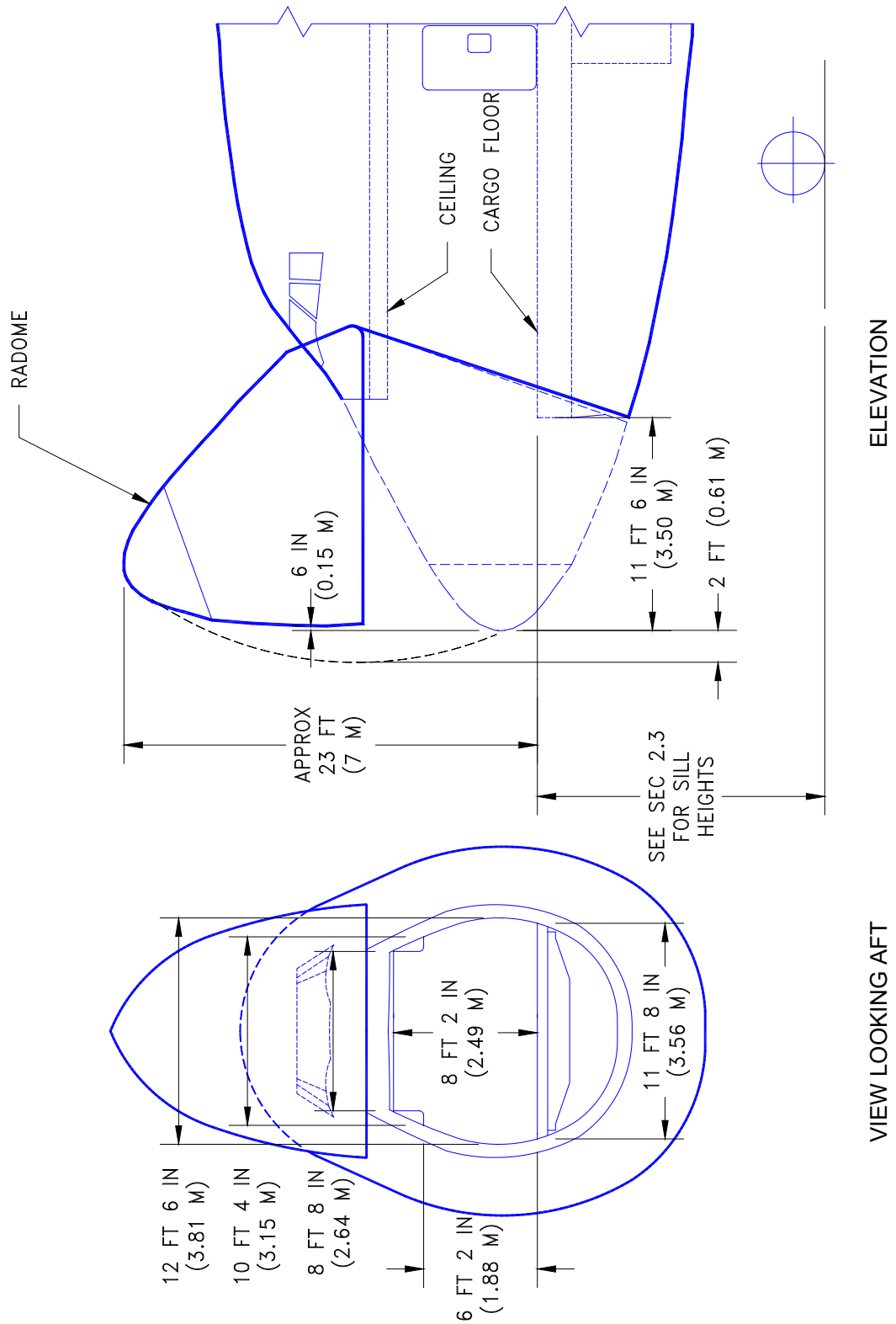

3.0 AIRPLANE PERFORMANCE

3.1 GENERAL INFORMATION

The graphs in Section 3.2 provide information on operational empty weight (OEW) and payload, trip range, brake release gross weight, and fuel limits for airplane models with the different engine options. To use these graphs, if the trip range and zero fuel weight (OEW + payload) are known, the approximate brake release weight can be found, limited by fuel quantity. Examples of loading conditions under certain OEW's are illustrated in each graph.

The graphs in Section 3.3 provide information on F.A.R. takeoff runway length requirements with the different engines at different pressure altitudes. Maximum takeoff weights shown on the graphs are the heaviest for the particular airplane models with the corresponding engines. Standard day temperatures for pressure altitudes shown on the F.A.R. takeoff graphs are given below:

PRESSURE ALTITUDE		STANDARD DAY TEMP	
FEET	METERS	°F	°C
0	0	59.0	15.00
2,000	610	51.9	11.04
4,000	1,219	44.7	7.06
6,000	1,829	37.6	3.11
8,000	2,438	30.5	-0.85
10,000	3,048	23.3	-4.81

3.2 PAYLOAD/RANGE

3.2.1 Payload/Range: Model 747-400, -400 Combi, 0.85 Mach Cruise (CF6-80C2B1F Engines)

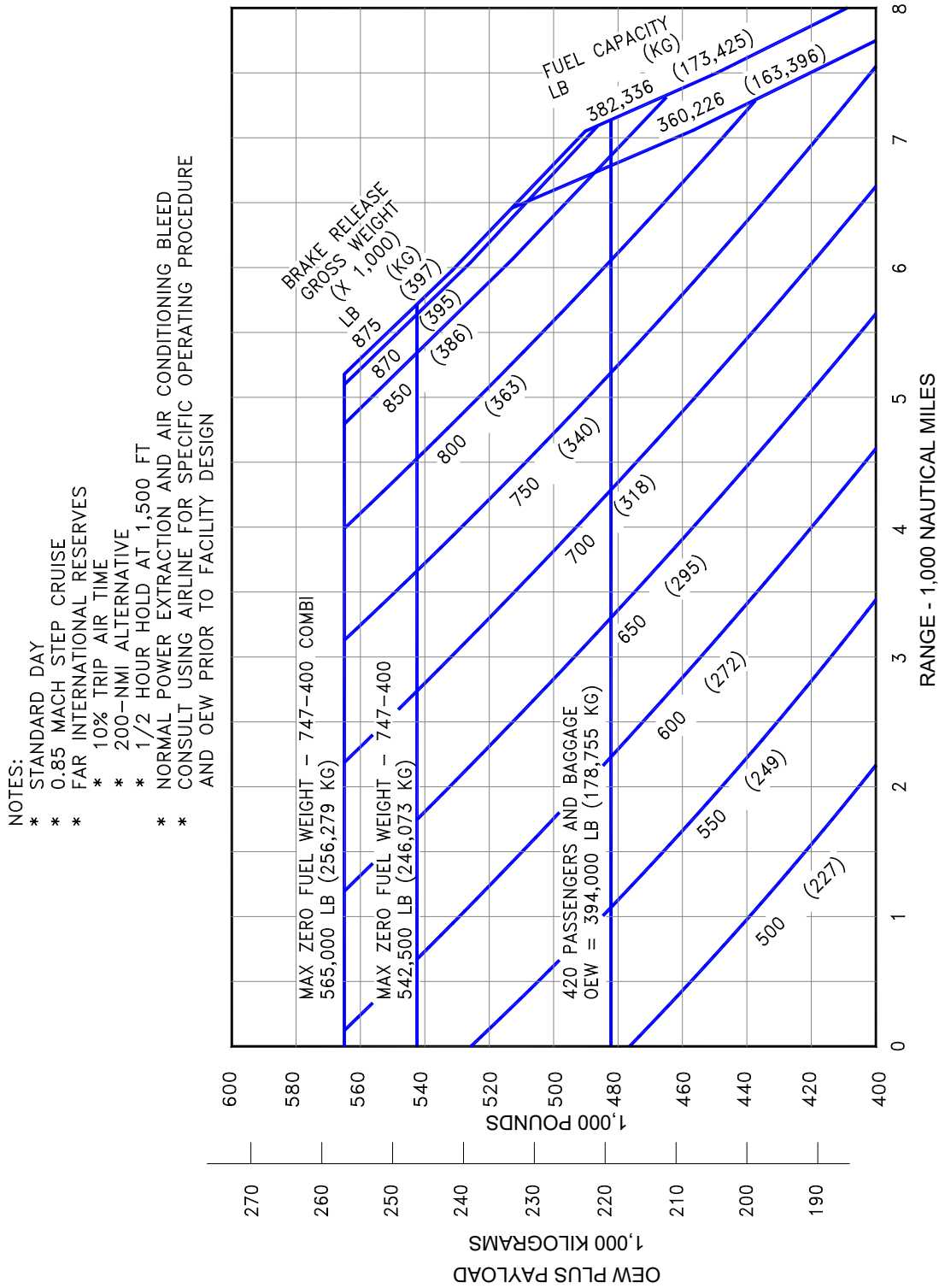

D6-58326-1

3.2.2 Payload/Range: Model 747-400, -400 Combi, 0.85 Mach Cruise (PW 4056 Engines)

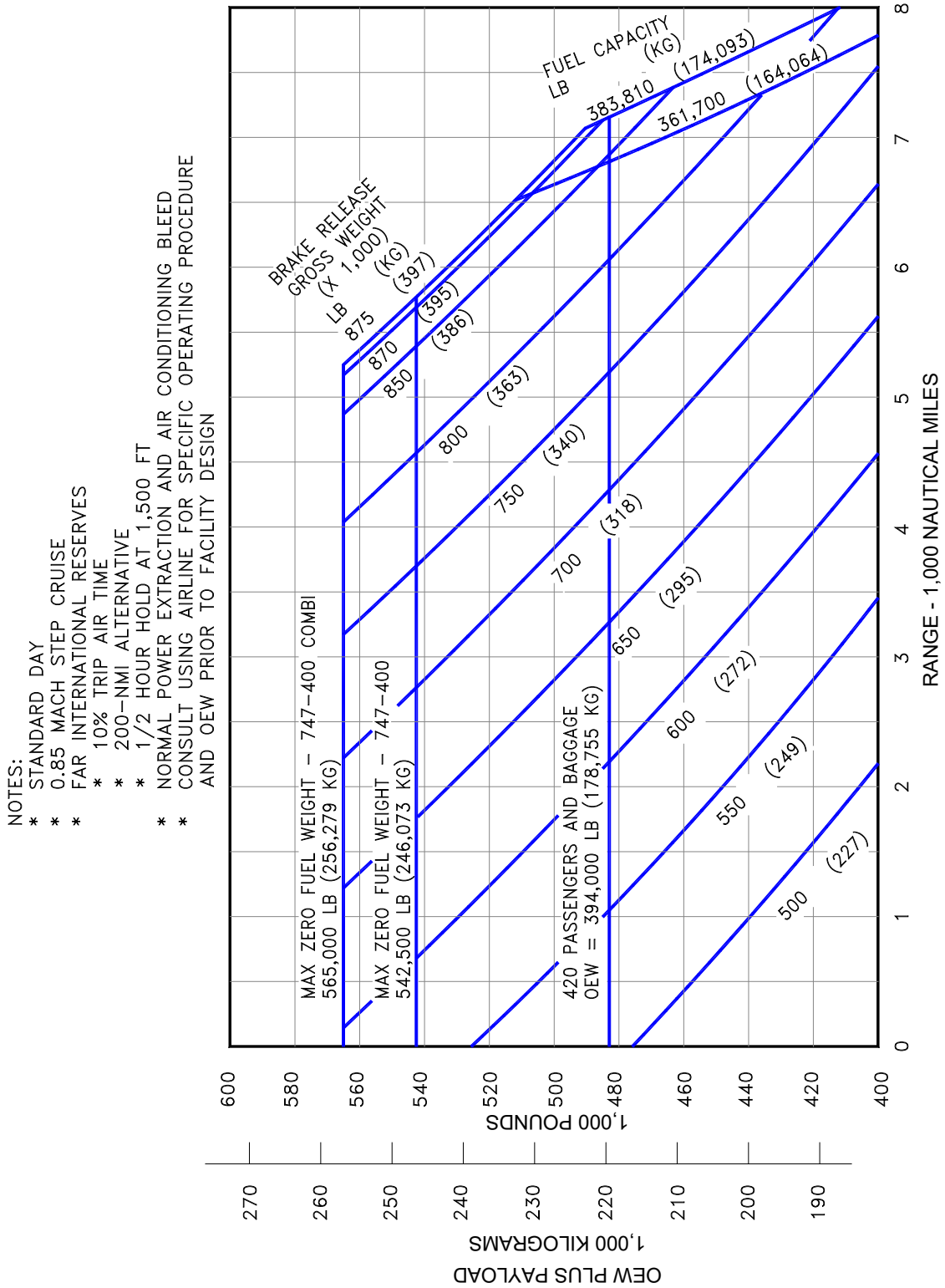

D6-58326-1

3.2.3 Payload/Range: Model 747-400, -400 Combi, 0.85 Mach Cruise (RB211-524G Engines)

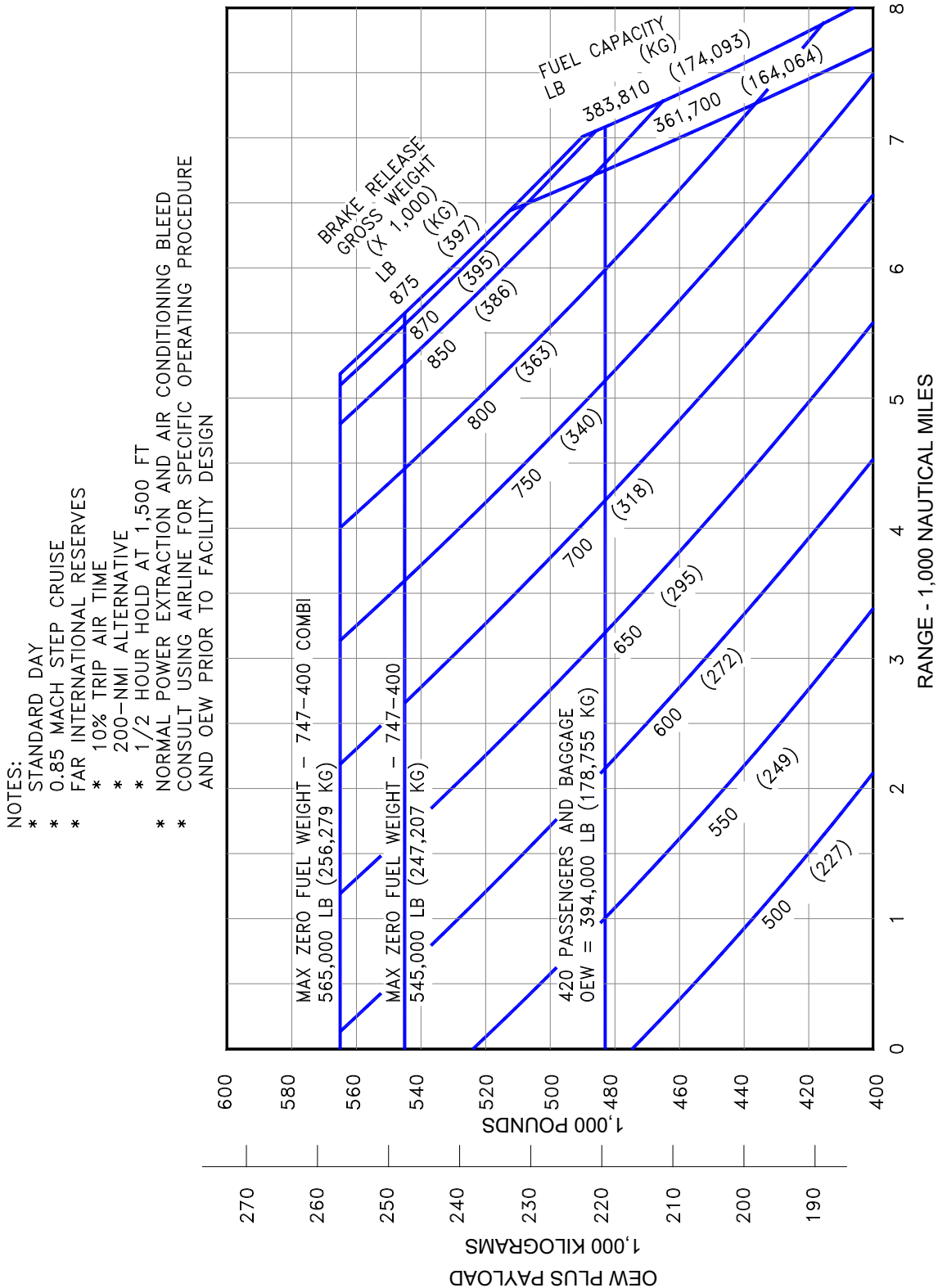

D6-58326-1

3.2.4 Payload/Range: Model 747-400, -400 Combi, 0.85 Mach Cruise (CF6-80C2B1F Engines)

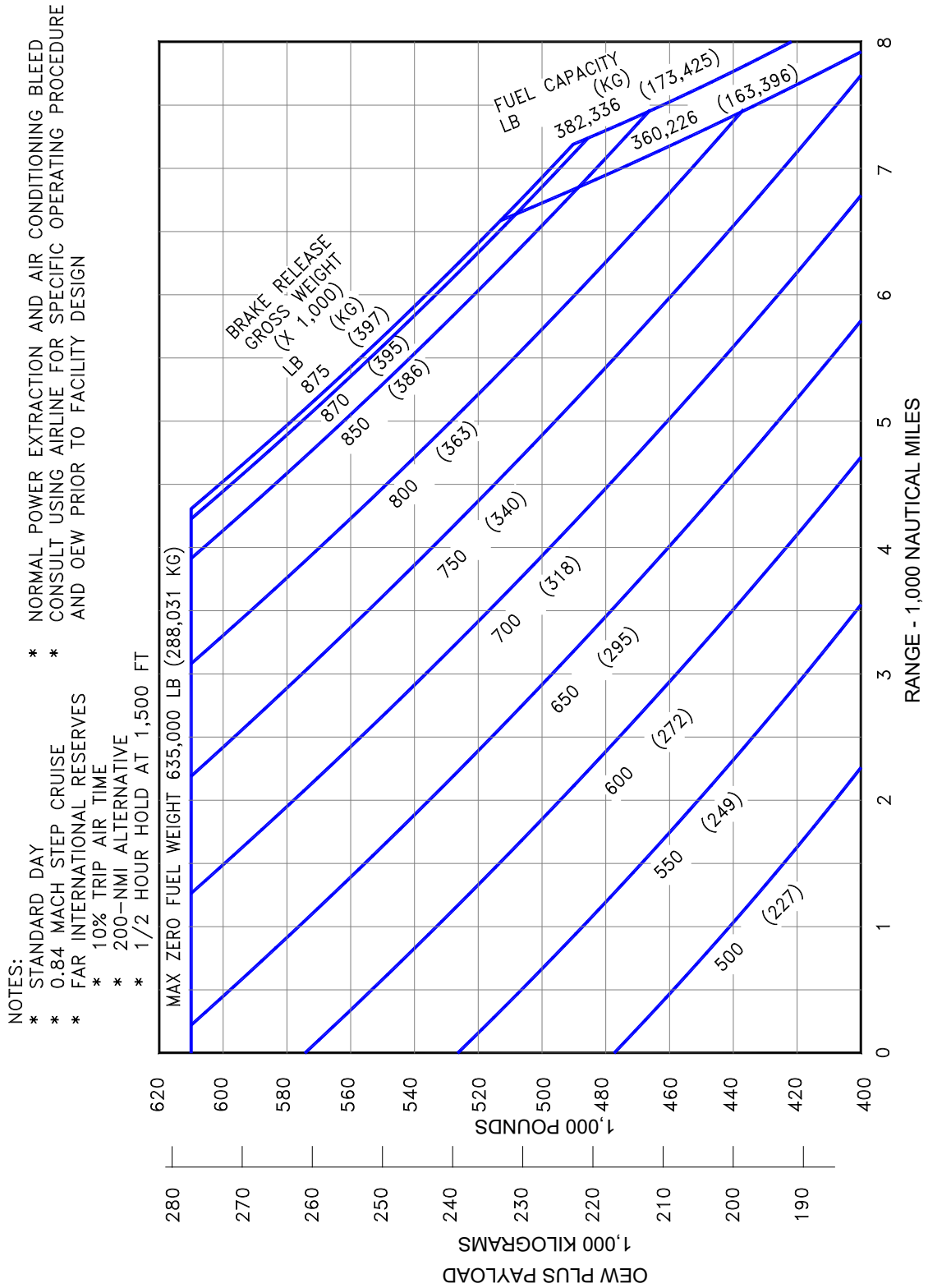

D6-58326-1

3.2.5 Payload/Range: Model 747-400ER, 0.85 Mach Cruise (CF6-80C2B5F Engines)

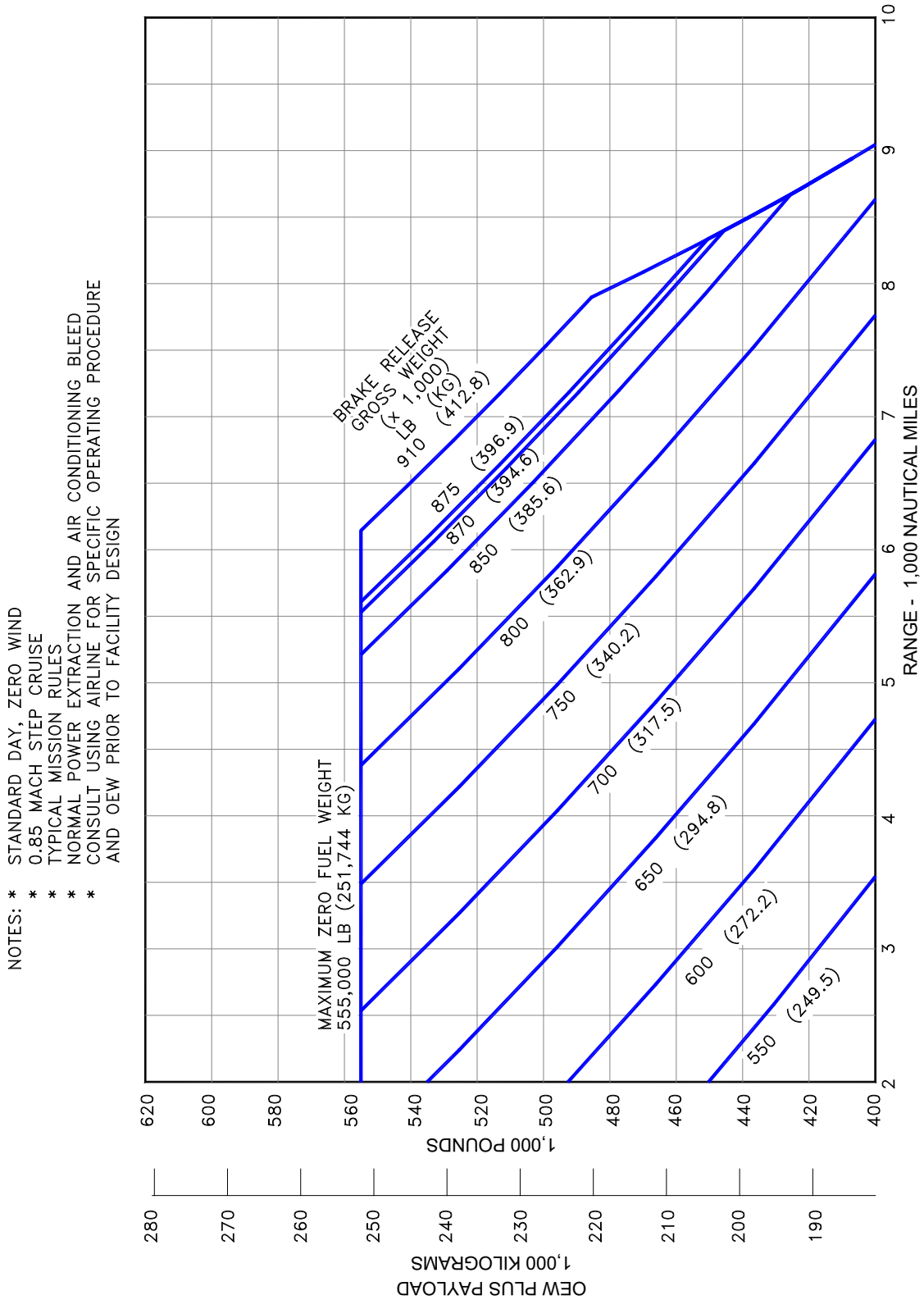

D6-58326-1

3.2.6 Payload/Range: Model 747-400ER, 0.85 Mach Cruise (PW 4062 Engines)

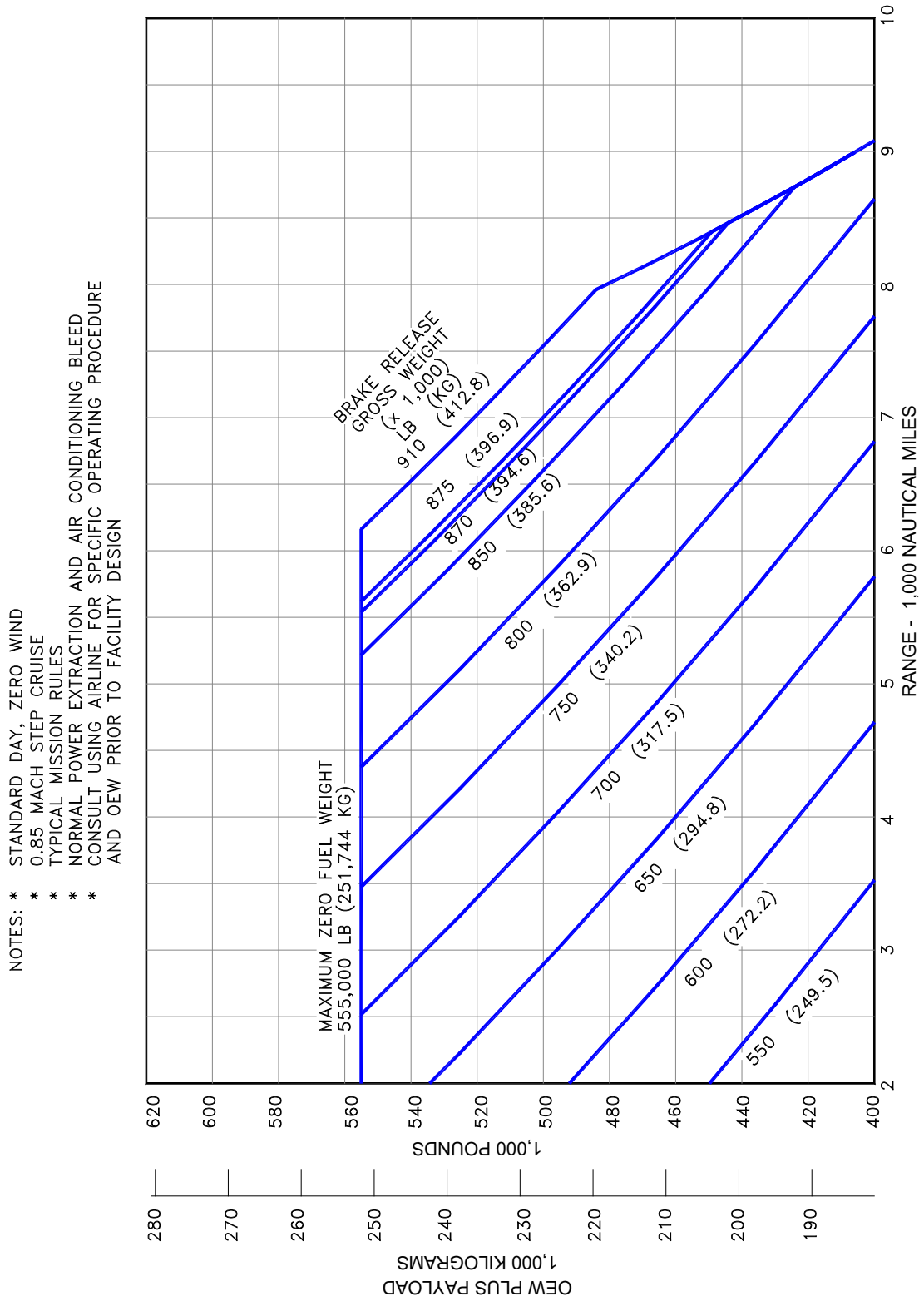

D6-58326-1

3.2.7 Payload/Range: Model 747-400ER, 0.85 Mach Cruise (RB211-524H8-T)

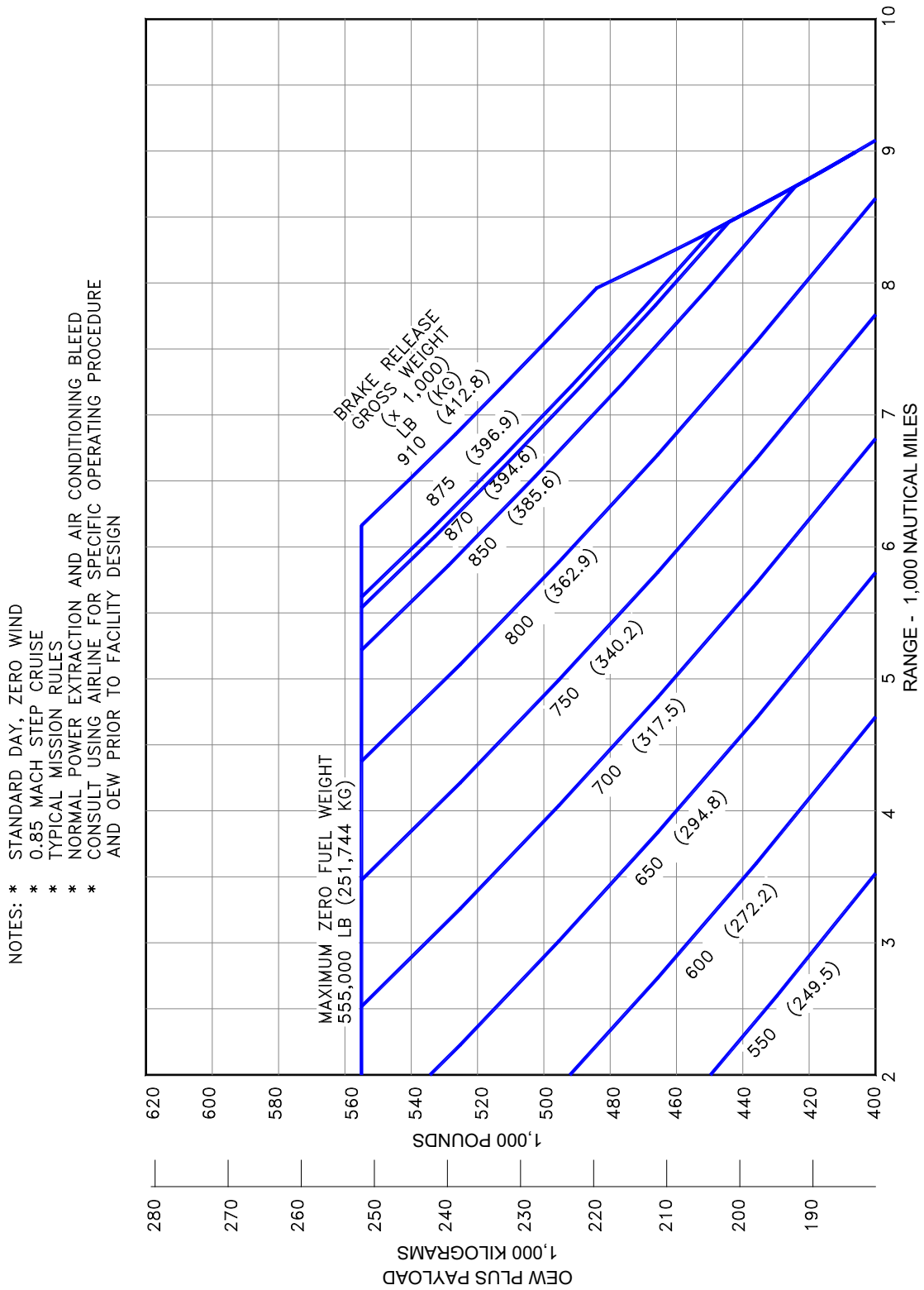

D6-58326-1

3.2.8 Payload/Range: Model 747-400ER Freighter, 0.85 Mach Cruise (CF6-80C2B5F Engines)

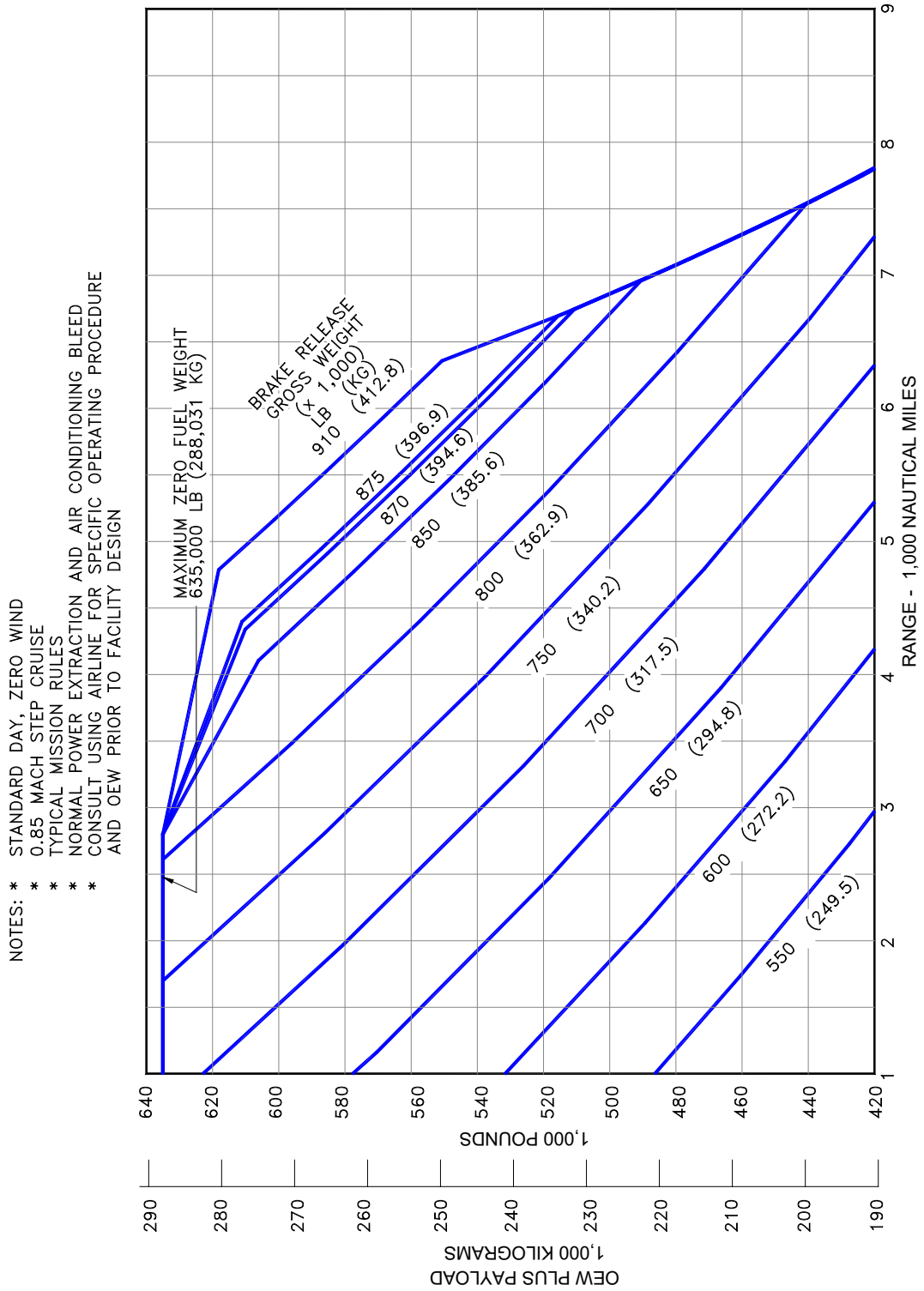

D6-58326-1

3.2.9 Payload/Range: Model 747-400ER Freighter, 0.85 Mach Cruise (PW 4062 Engines)

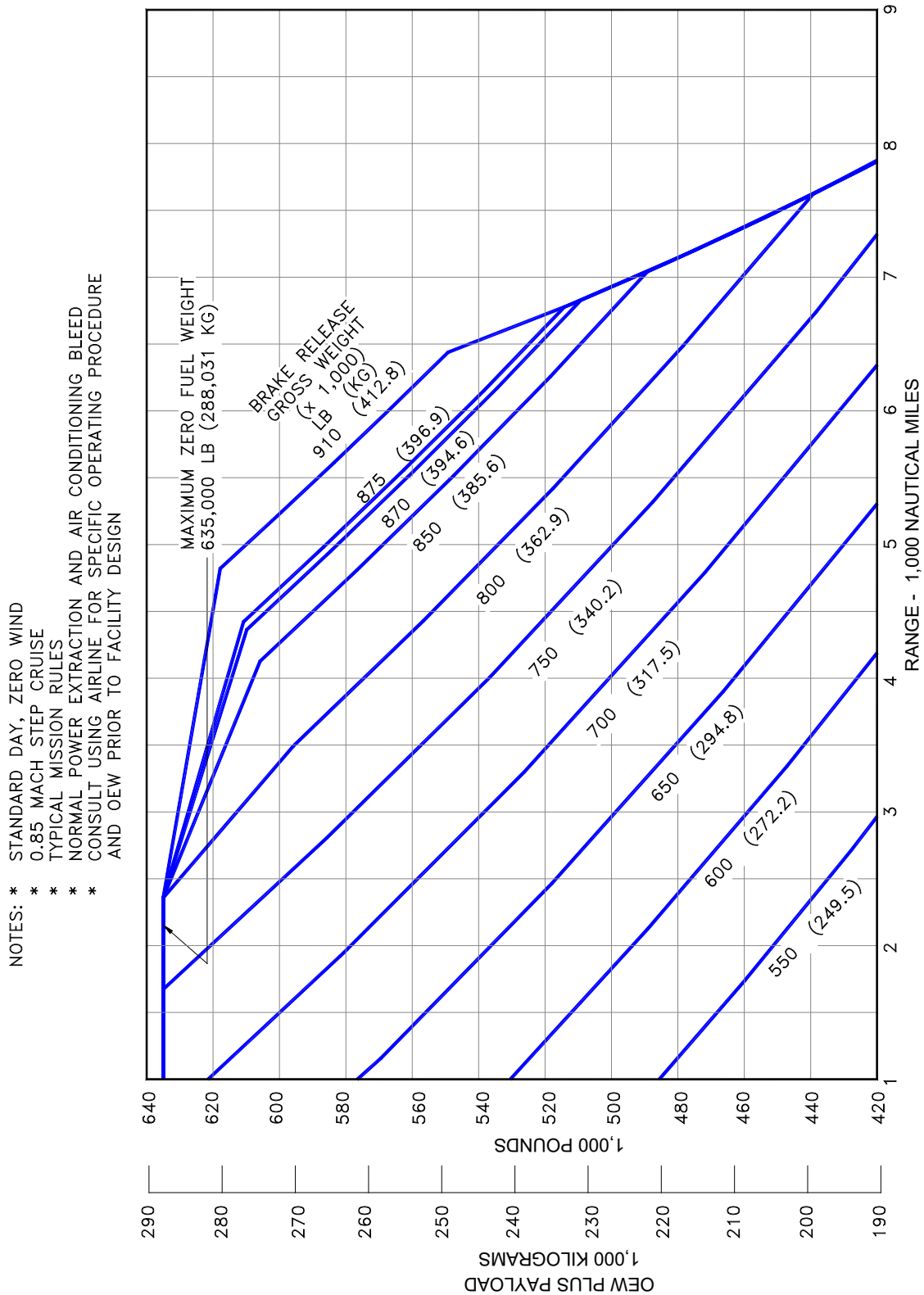

D6-58326-1

3.2.10 Payload/Range: Model 747-400ER Freighter, 0.85 Mach Cruise (RB211-524H8-T Engines)

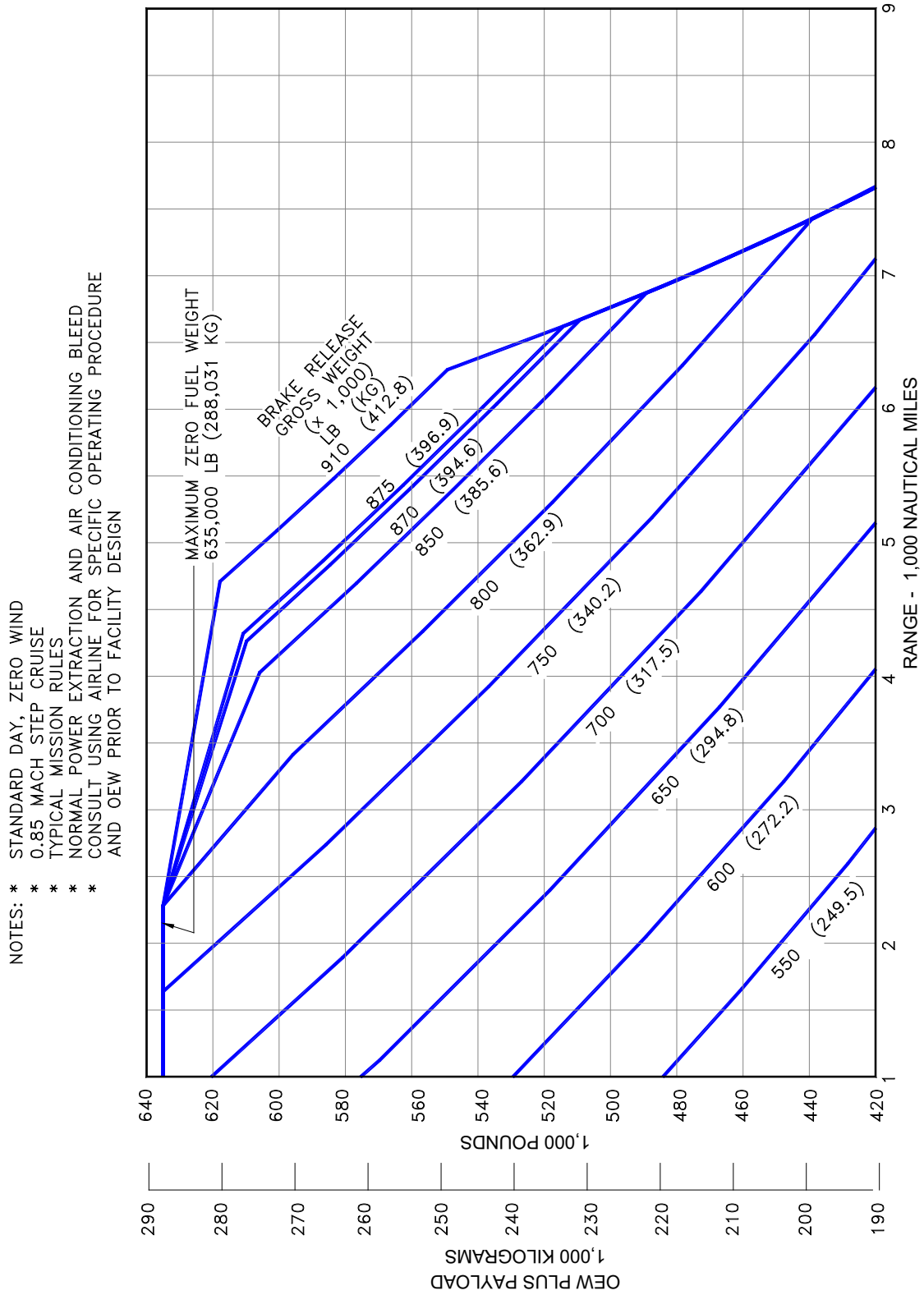

D6-58326-1

3.2.11 Payload/Range: Model 747-400 Domestic, 0.85 Mach Cruise (CF6-80C2B1F Engines)

- NOTES:
- * STANDARD DAY
 - * 0.84 MACH STEP CRUISE
 - * FAR INTERNATIONAL RESERVES
 - * 10% TRIP AIR TIME
 - * 200-NMI ALTERNATIVE
 - * 1/2 HOUR HOLD AT 1,500 FT
 - * NORMAL POWER EXTRACTION AND AIR CONDITIONING BLEED
 - * CONSULT USING AIRLINE FOR SPECIFIC OPERATING PROCEDURE AND OEW PRIOR TO FACILITY DESIGN

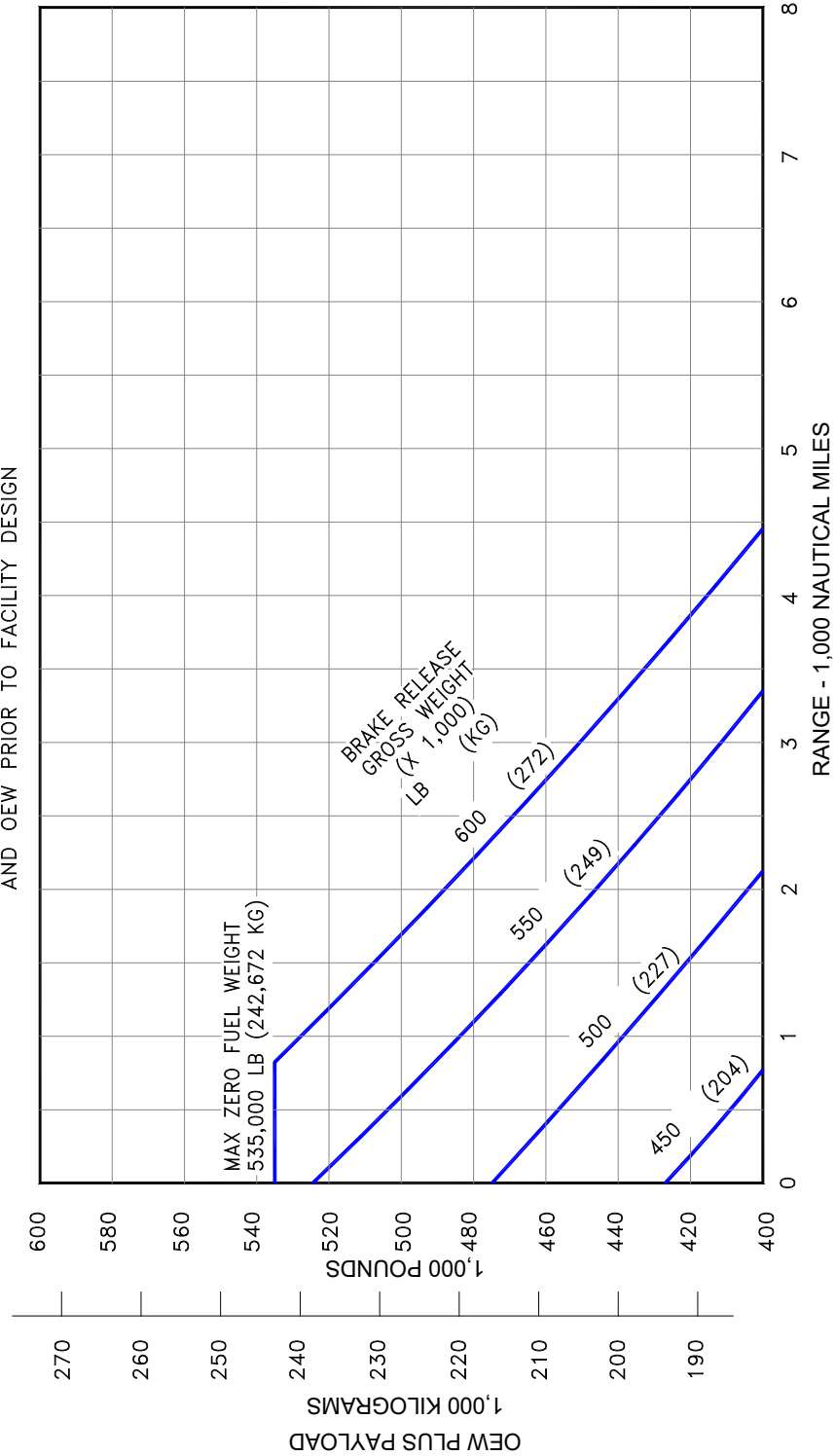

D6-58326-1

3.3 F.A.R. TAKEOFF RUNWAY LENGTH REQUIREMENTS

3.3.1 F.A.R. Takeoff Runway Length Requirements - Standard Day: Model 747-400 (CF6-80C2B1 Engines)

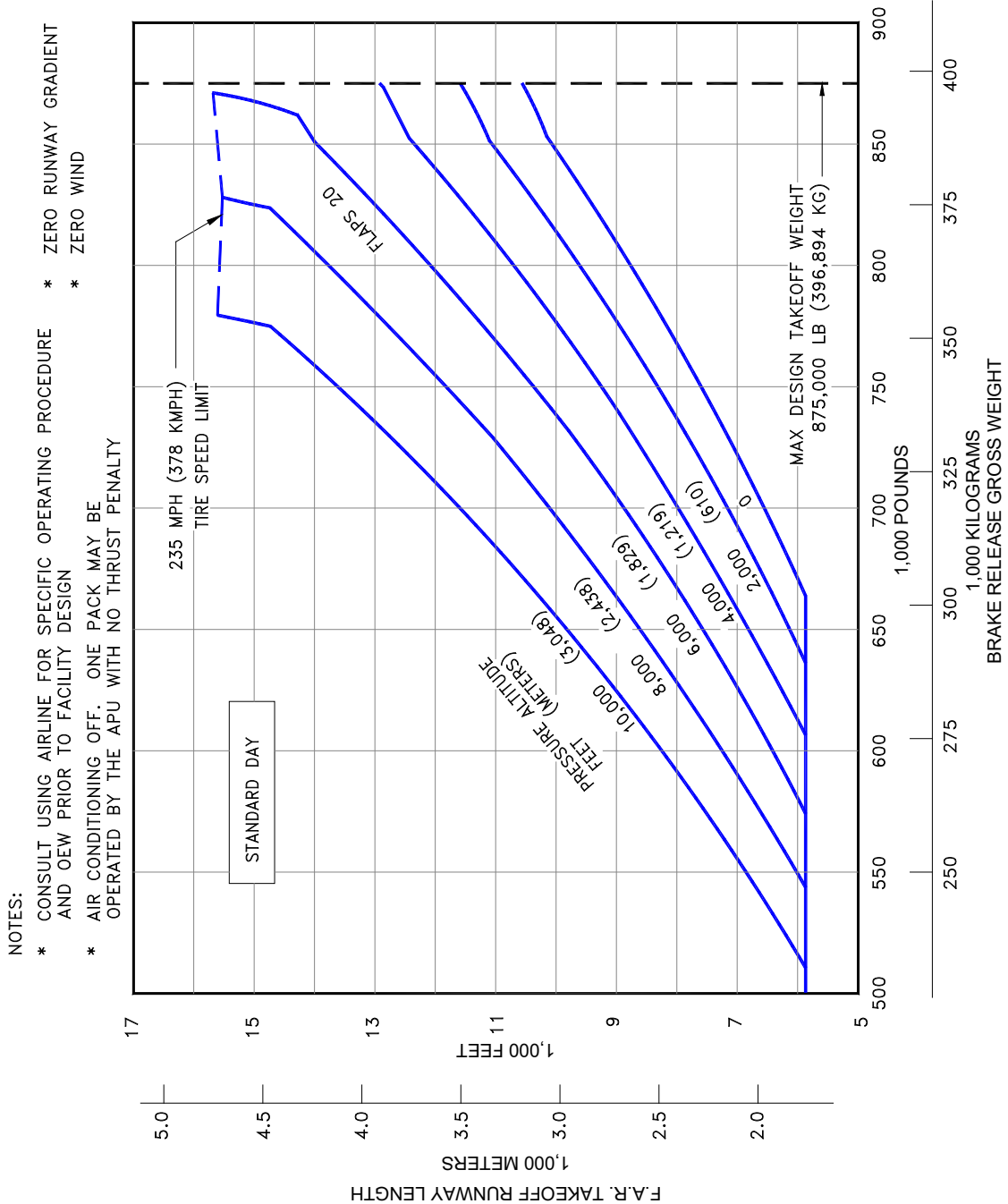

3.3.2 F.A.R. Takeoff Runway Length Requirements - Standard Day + 31°F (STD + 17.2°C): Model 747-400 (CF6-80C2B1 Engines)

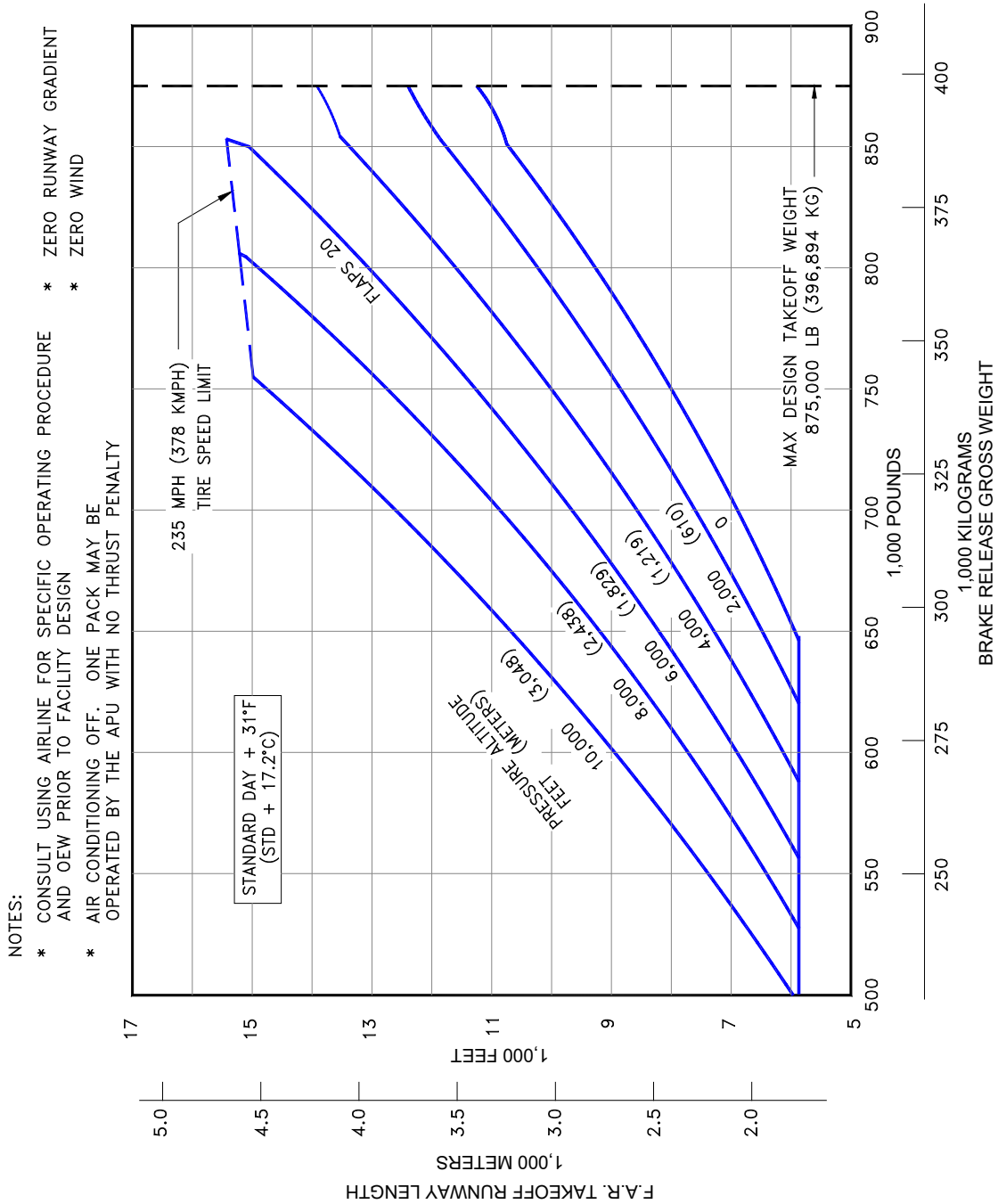

D6-58326-1

3.3.3 F.A.R. Takeoff Runway Length Requirements - Standard Day: Model 747-400 (PW-4056 Engines)

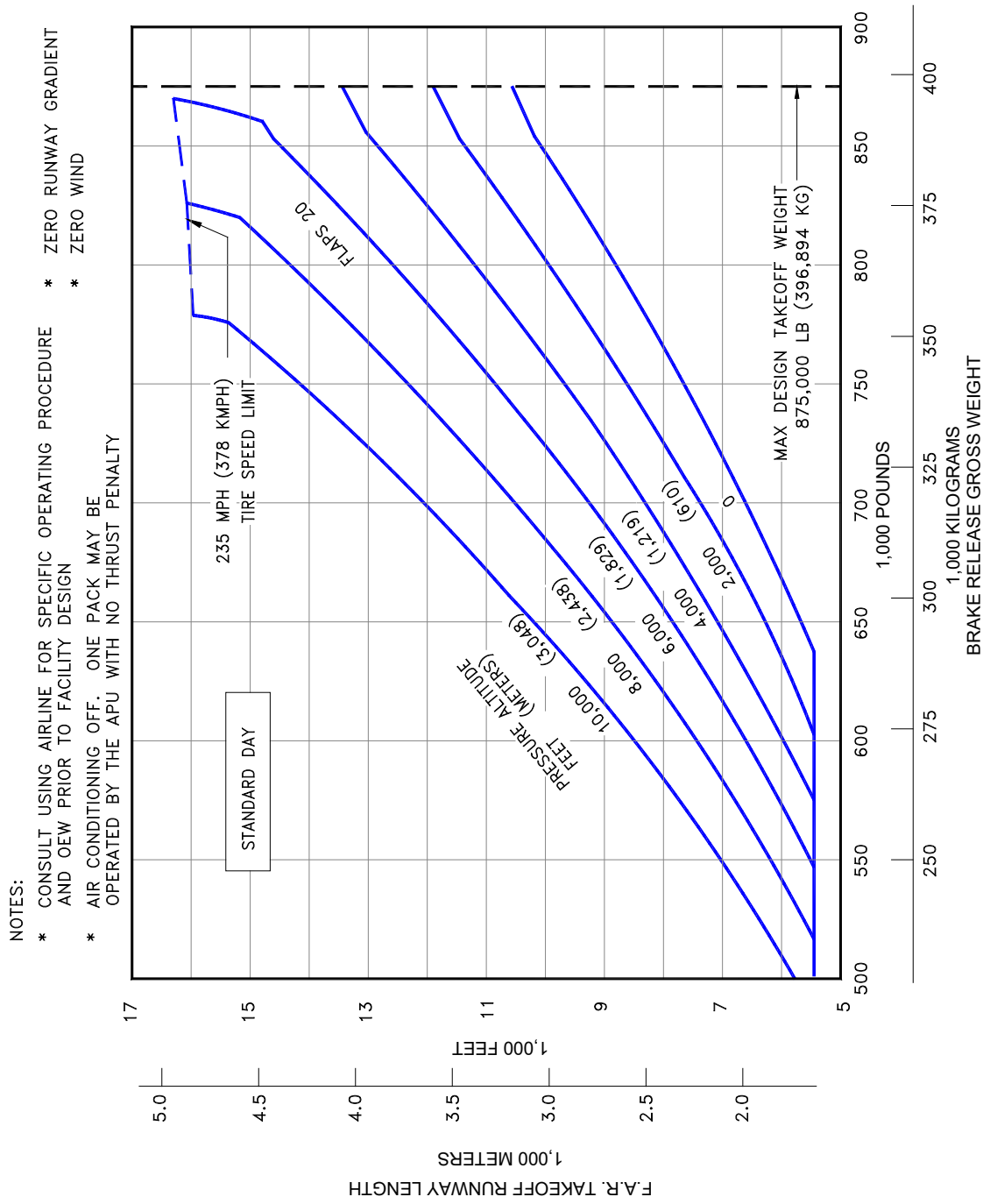

D6-58326-1

3.3.4 F.A.R. Takeoff Runway Length Requirements - Standard Day + 33°F (STD + 18.3°C): Model 747-400 (PW4056 Engines)

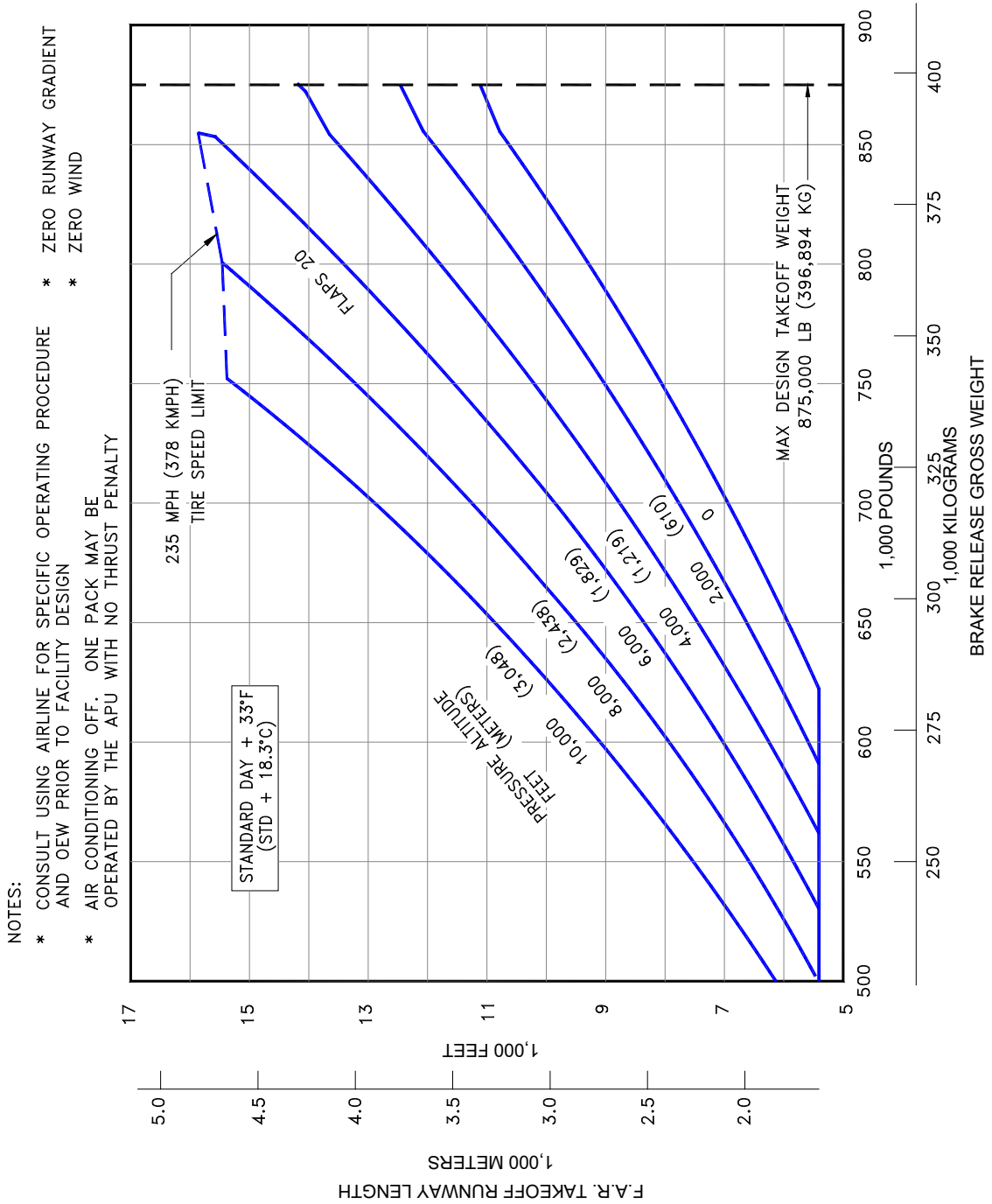

D6-58326-1

3.3.5 F.A.R. Takeoff Runway Length Requirements - Standard Day: Model 747-400 (RB211-524G2 Engines)

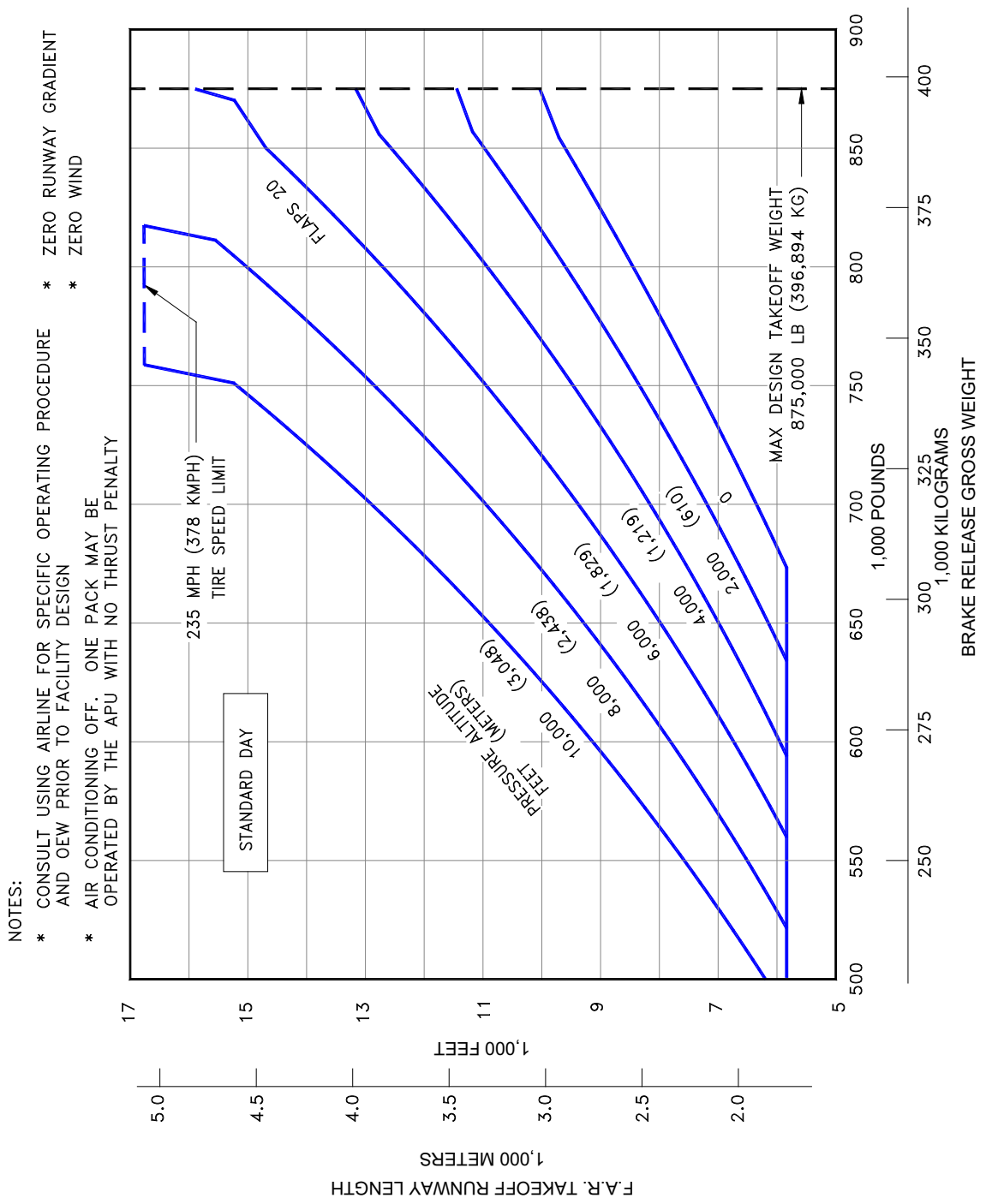

D6-58326-1

3.3.6 F.A.R. Takeoff Runway Length Requirements - Standard Day + 27°F (STD + 15°C): Model 747-400 (RB211-524G2 Engines)

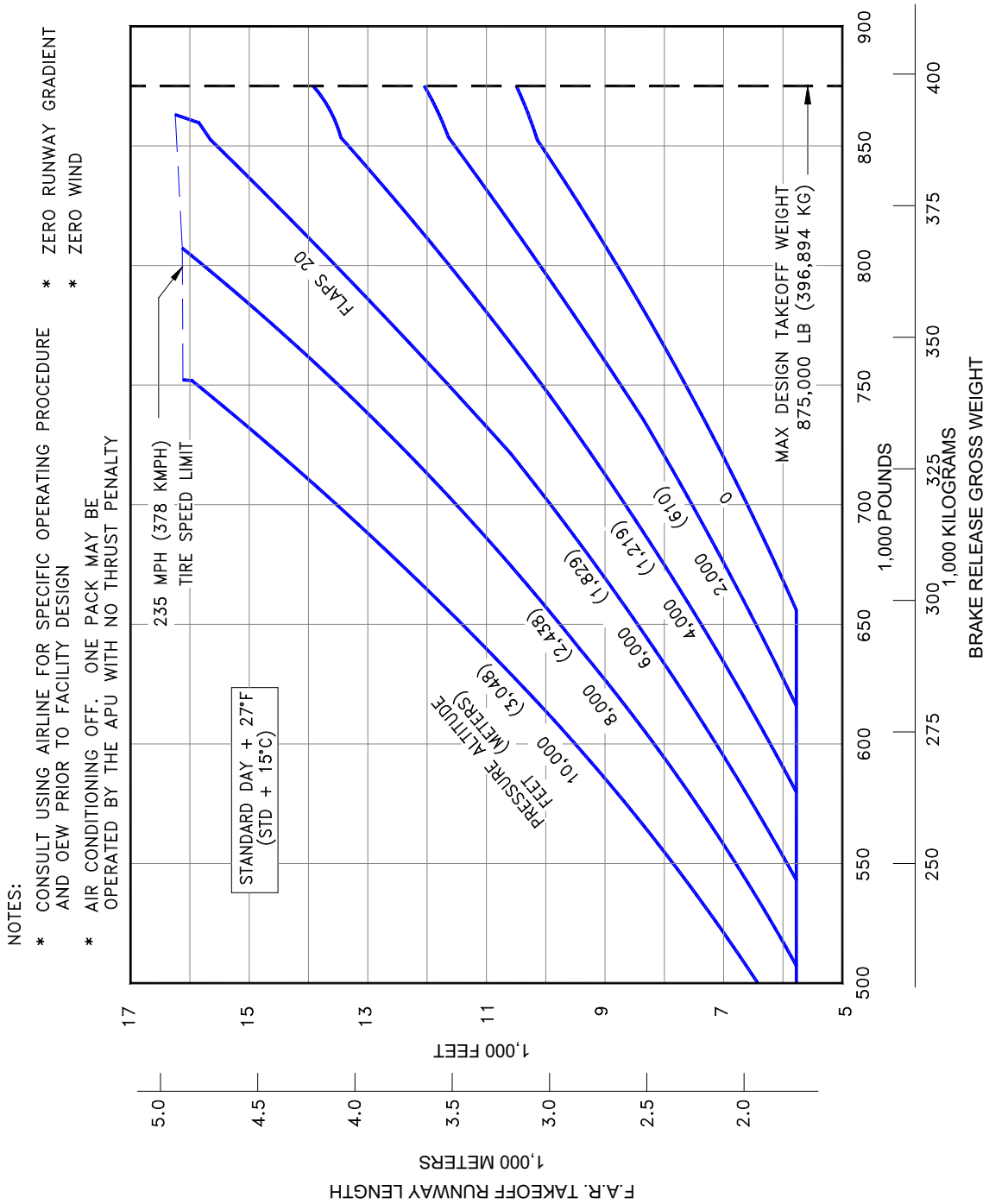

D6-58326-1

3.3.7 F.A.R. Takeoff Runway Length Requirements - Standard Day: Model 747-400 Freighter (CF6-80C2B1 Engines)

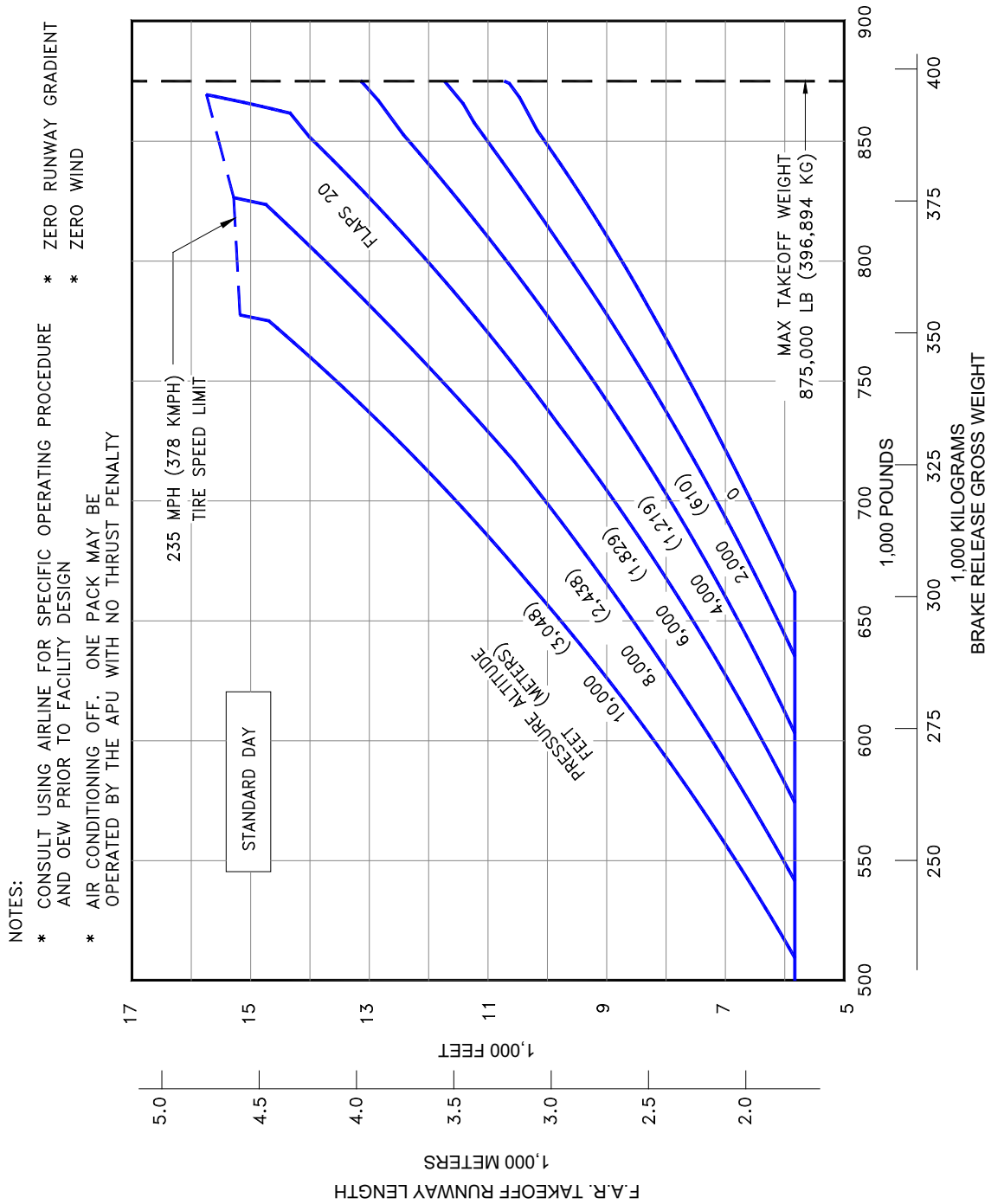

D6-58326-1

3.3.8 F.A.R. Takeoff Runway Length Requirements - Standard Day + 31°F (STD + 17.2°C): Model 747-400 Freighter (CF6-80C2B1 Engines)

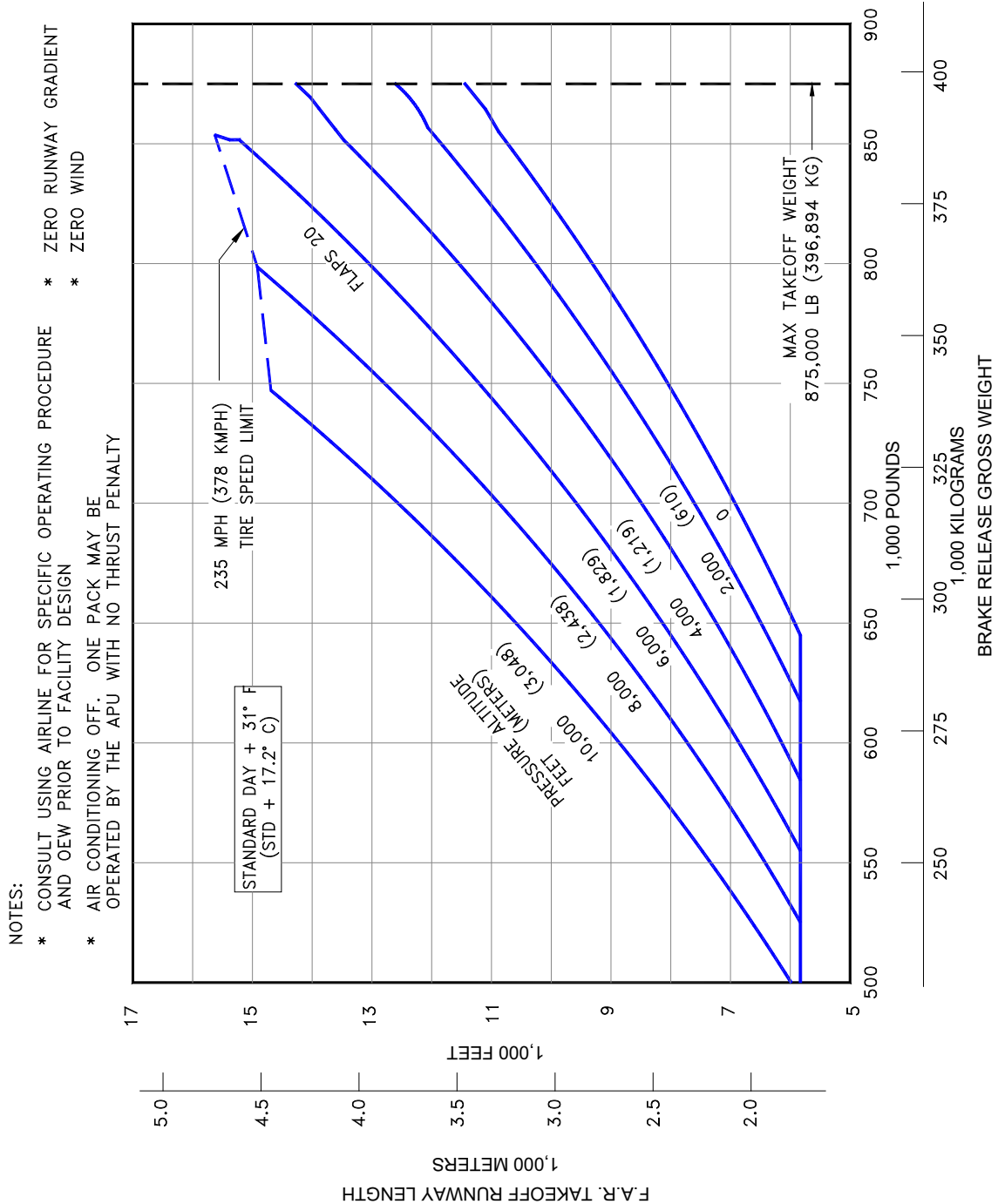

D6-58326-1

3.3.9 F.A.R. Takeoff Runway Length Requirements - Standard Day: Model 747-400ER (CF6-80C2B5F Engines)

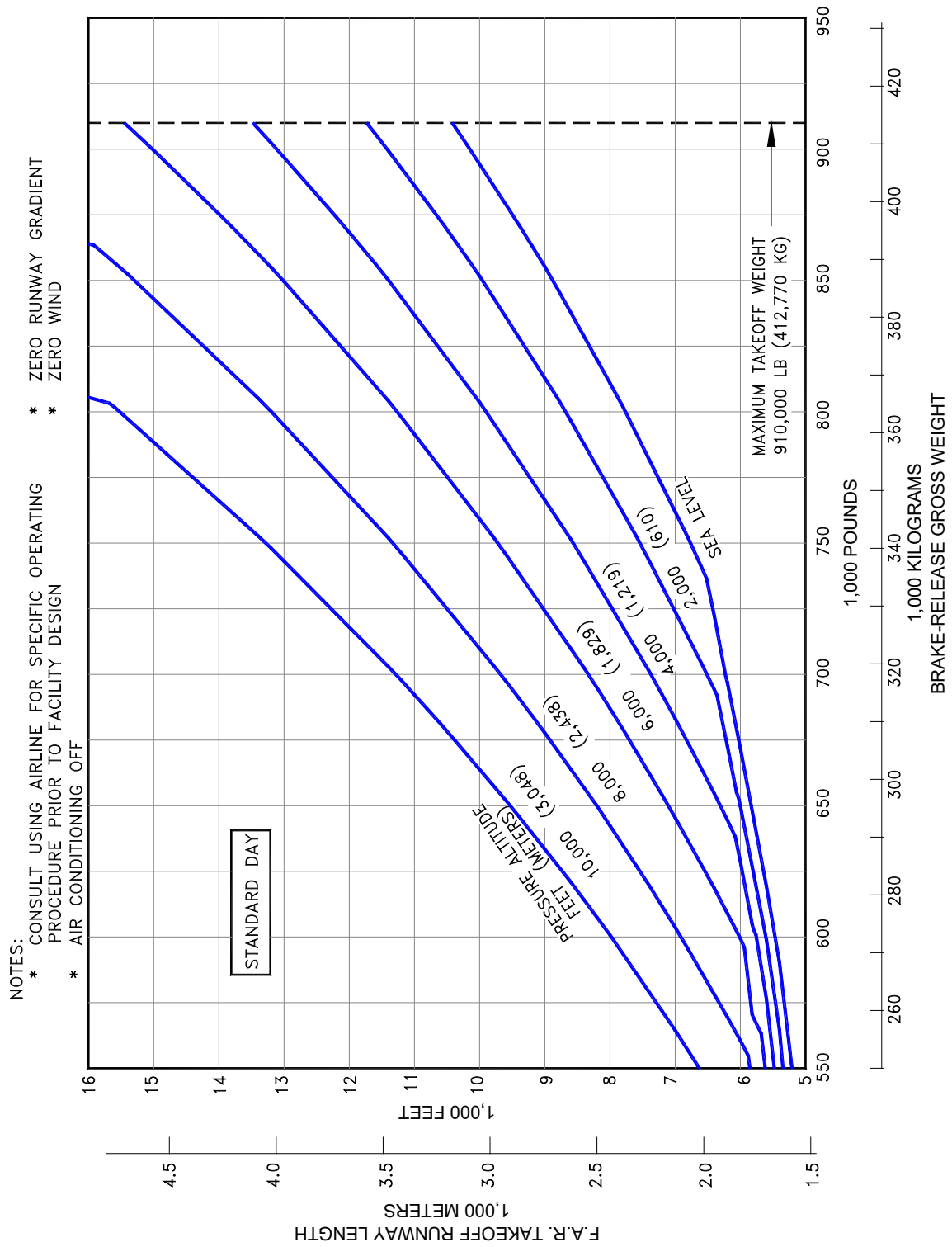

D6-58326-1

3.3.10 F.A.R. Takeoff Runway Length Requirements - Standard Day + 31°F (STD + 17.2°C): Model 747-400ER (CF6-80C2B5F Engines)

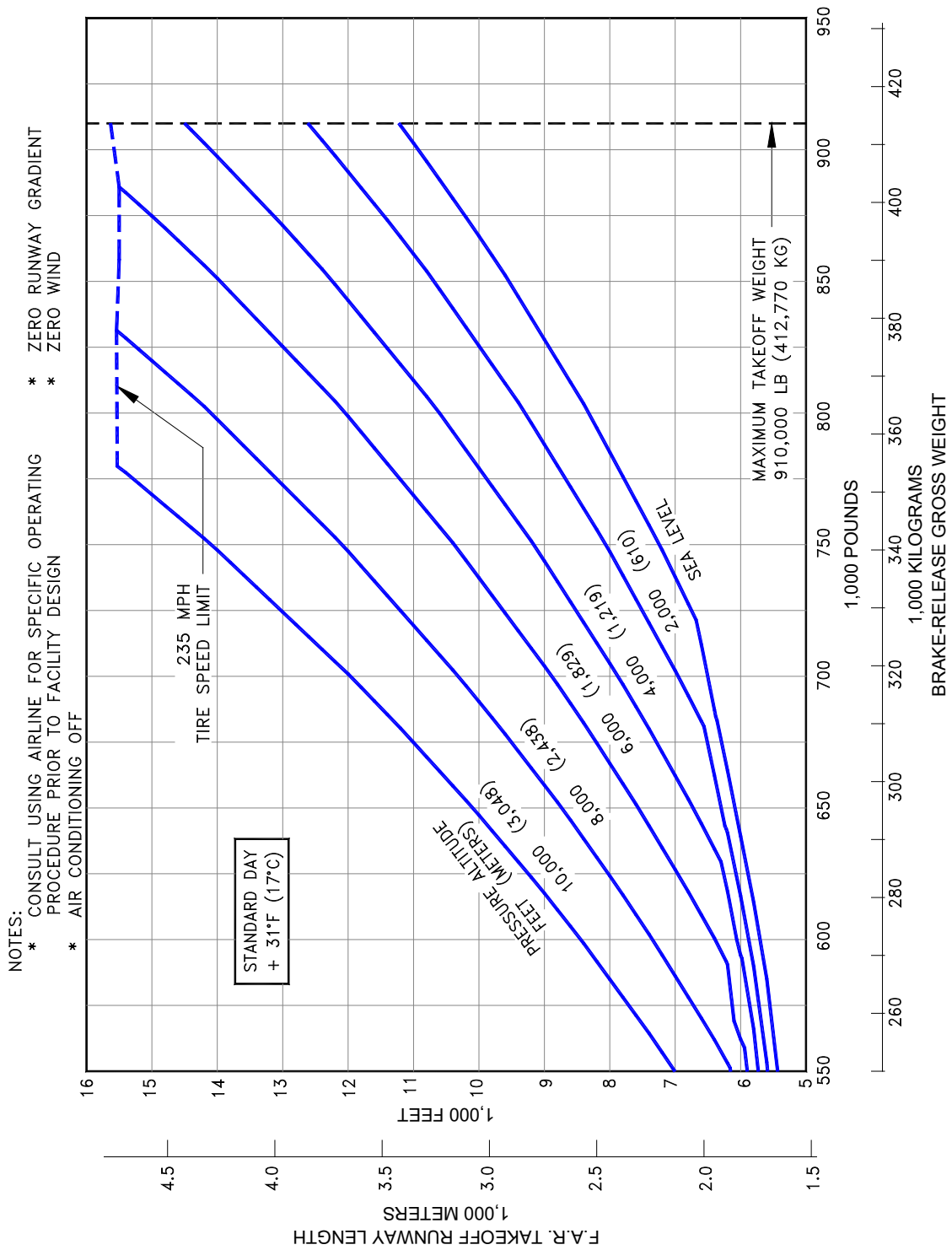

D6-58326-1

3.3.11 F.A.R. Takeoff Runway Length Requirements - Standard Day: Model 747-400ER (PW-4062 Engines)

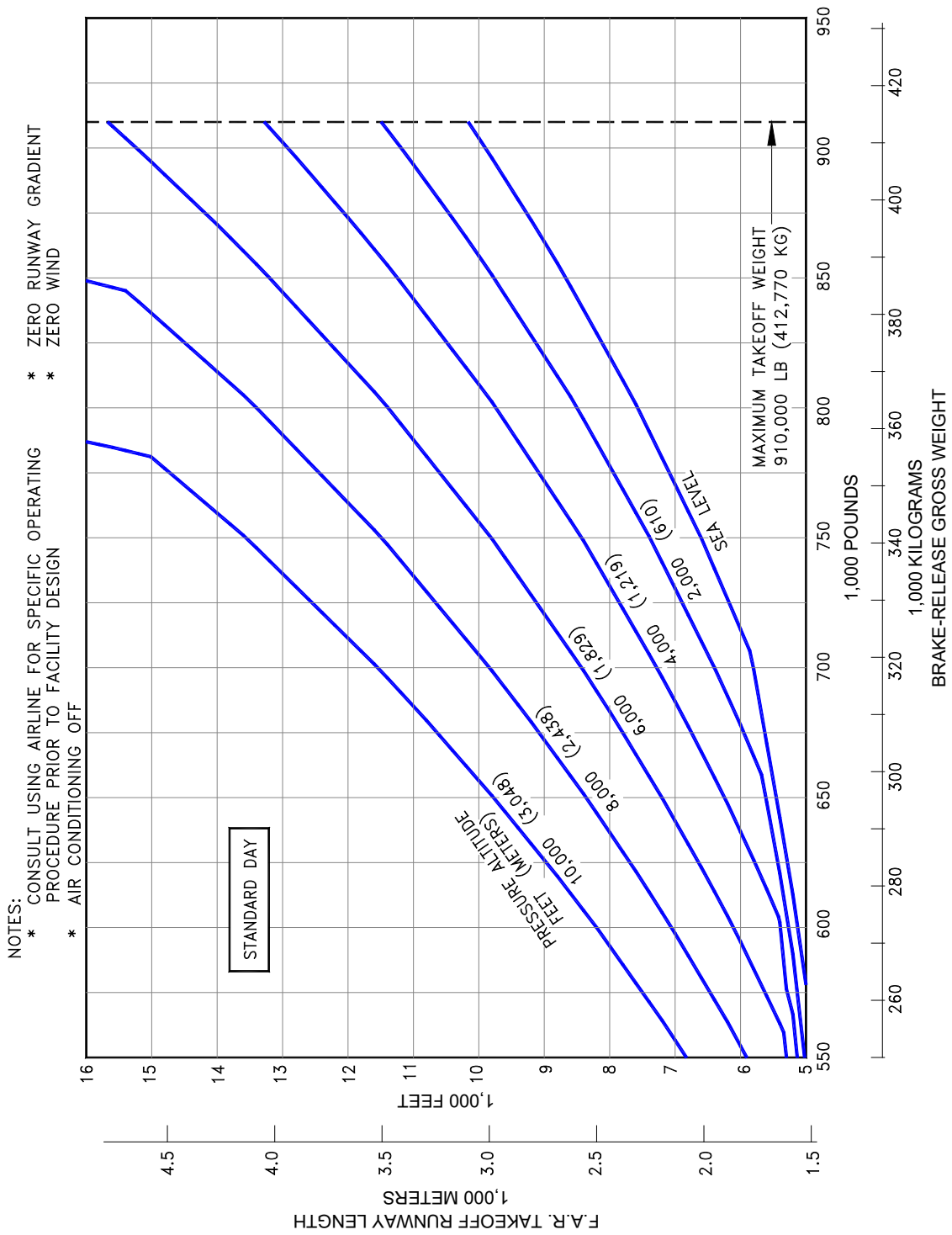

D6-58326-1

3.3.12 F.A.R. Takeoff Runway Length Requirements - Standard Day + 31°F (STD + 17°C): Model 747-400ER (PW4062 Engines)

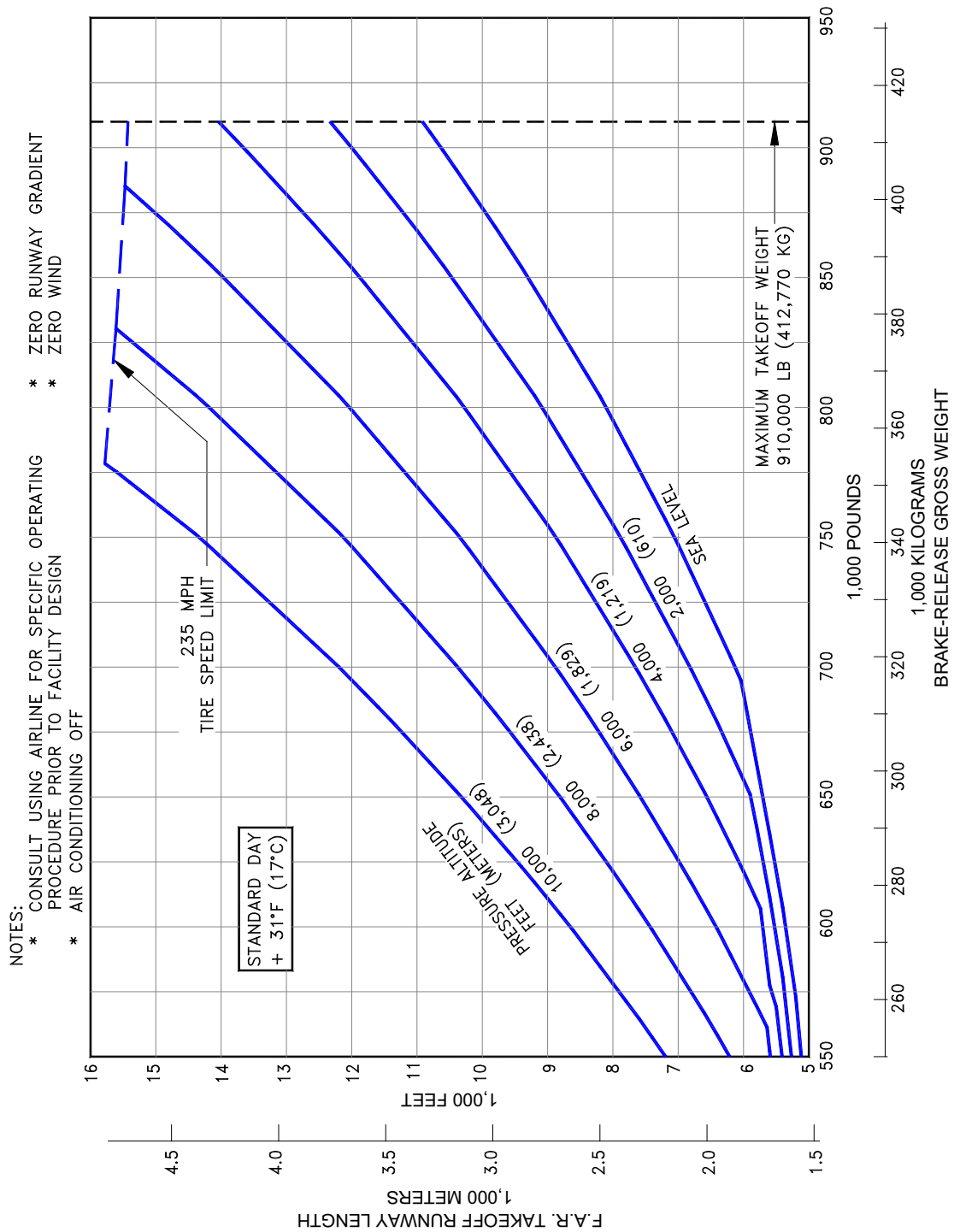

D6-58326-1

3.3.13 F.A.R. Takeoff Runway Length Requirements - Standard Day: Model 747-400ER (RB211-524H8-T Engines)

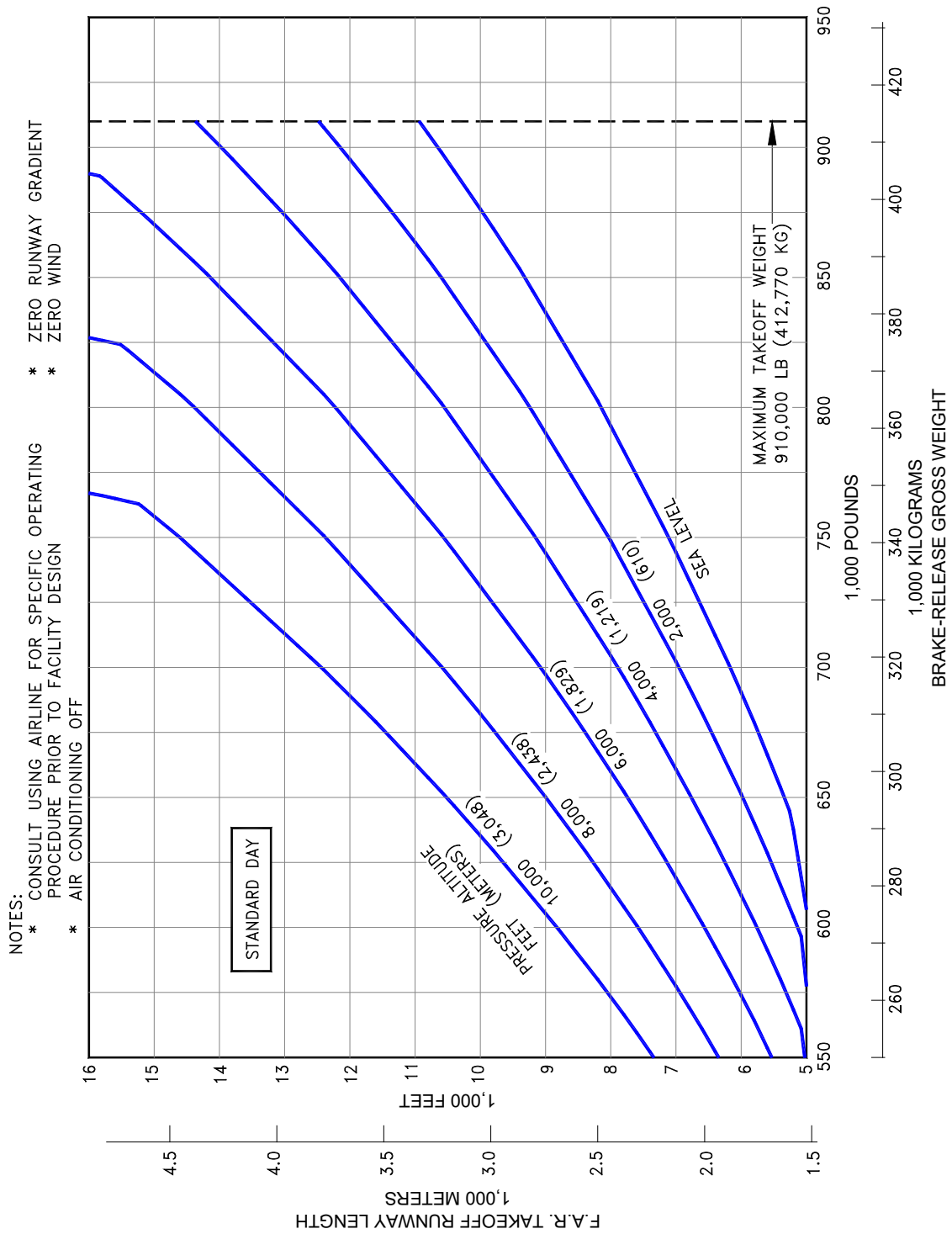

D6-58326-1

3.3.14 F.A.R. Takeoff Runway Length Requirements - Standard Day + 31°F (STD + 17°C): Model 747-400ER (RB211-524H8-T Engines)

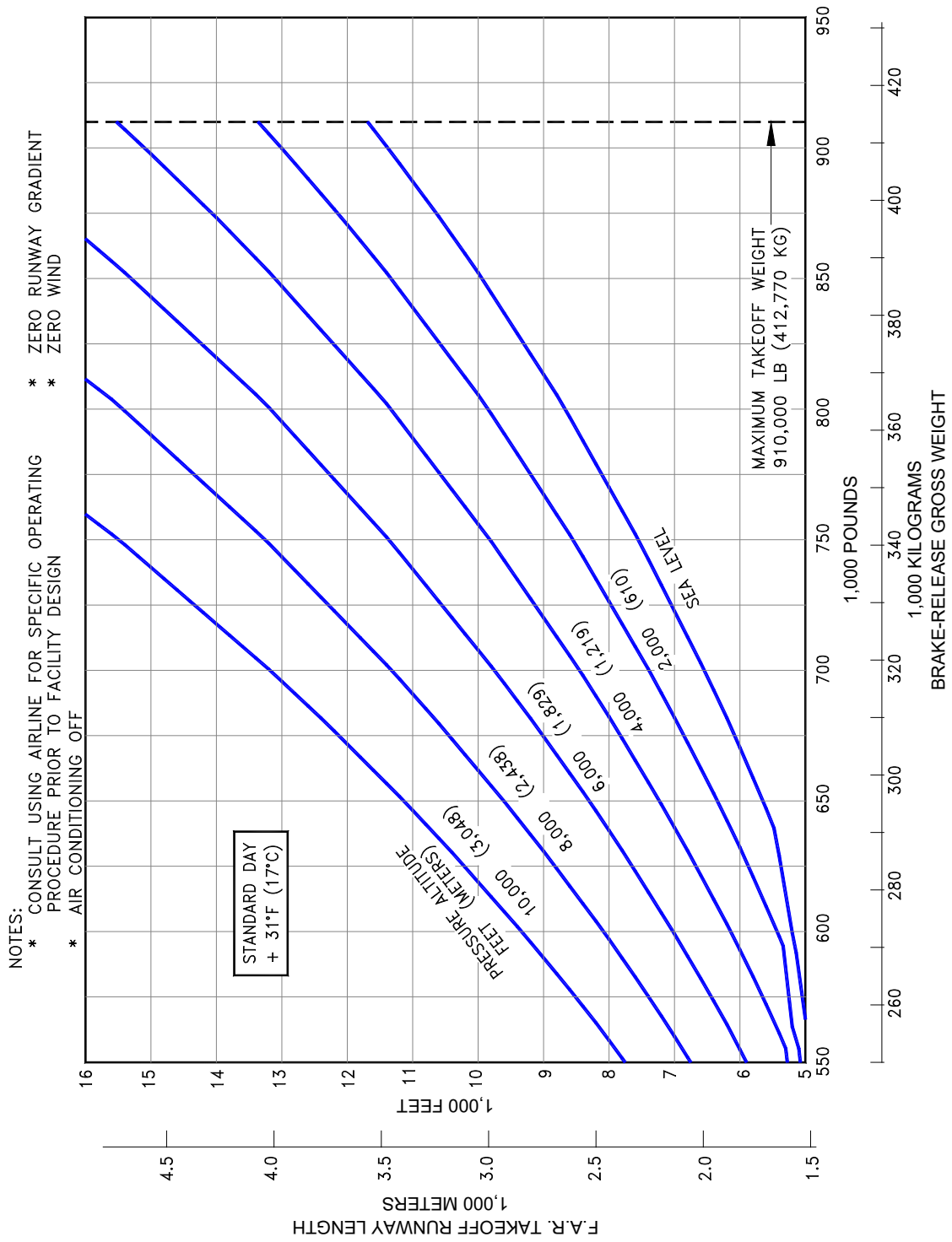

D6-58326-1

3.3.15 F.A.R. Takeoff Runway Length Requirements - Standard Day: Model 747-400ER Freighter (CF6-80C2B5F Engines)

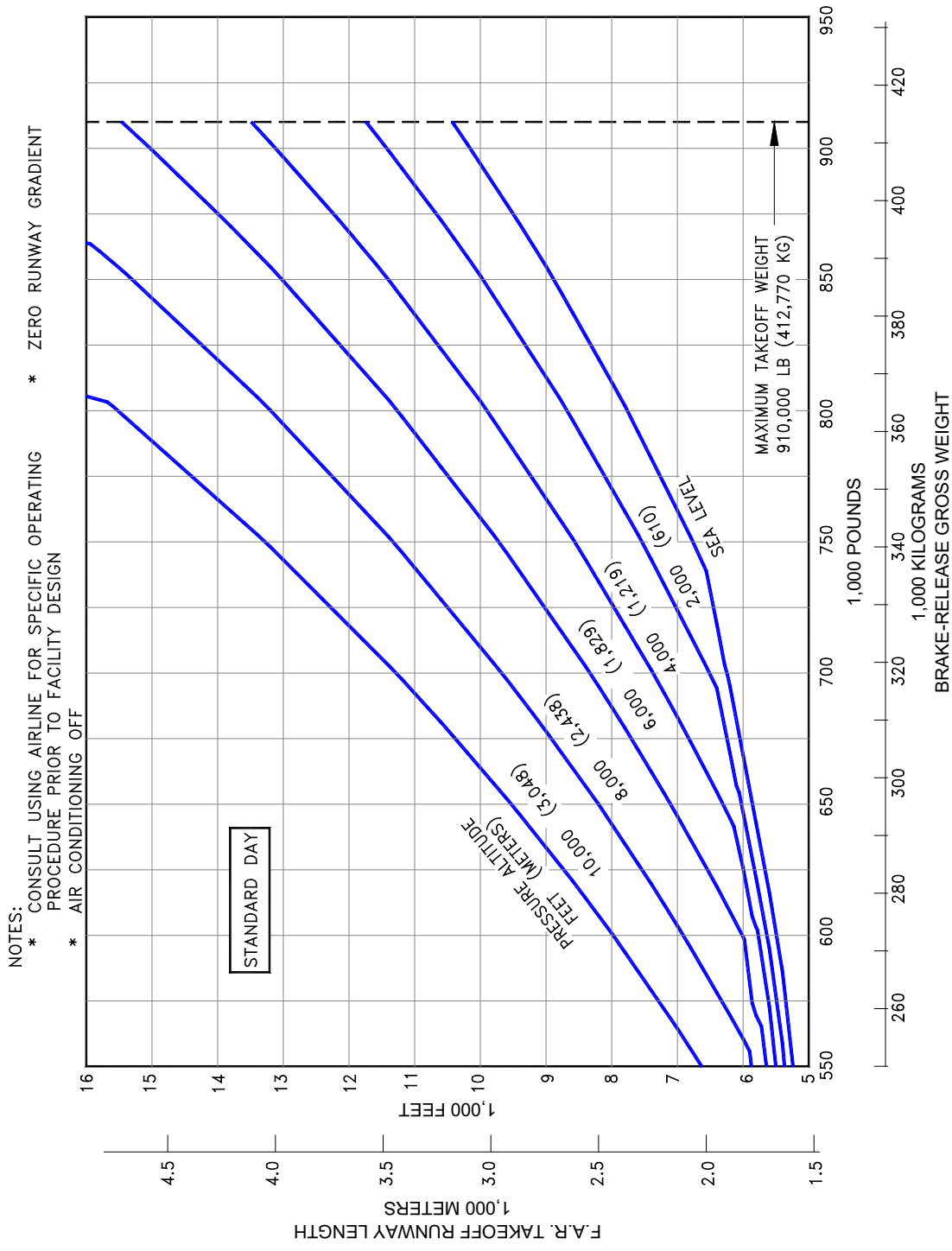

D6-58326-1

3.3.16 F.A.R. Takeoff Runway Length Requirements - Standard Day + 31°F (STD + 17°C): Model 747-400ER Freighter (CF6-80C2B5F Engines)

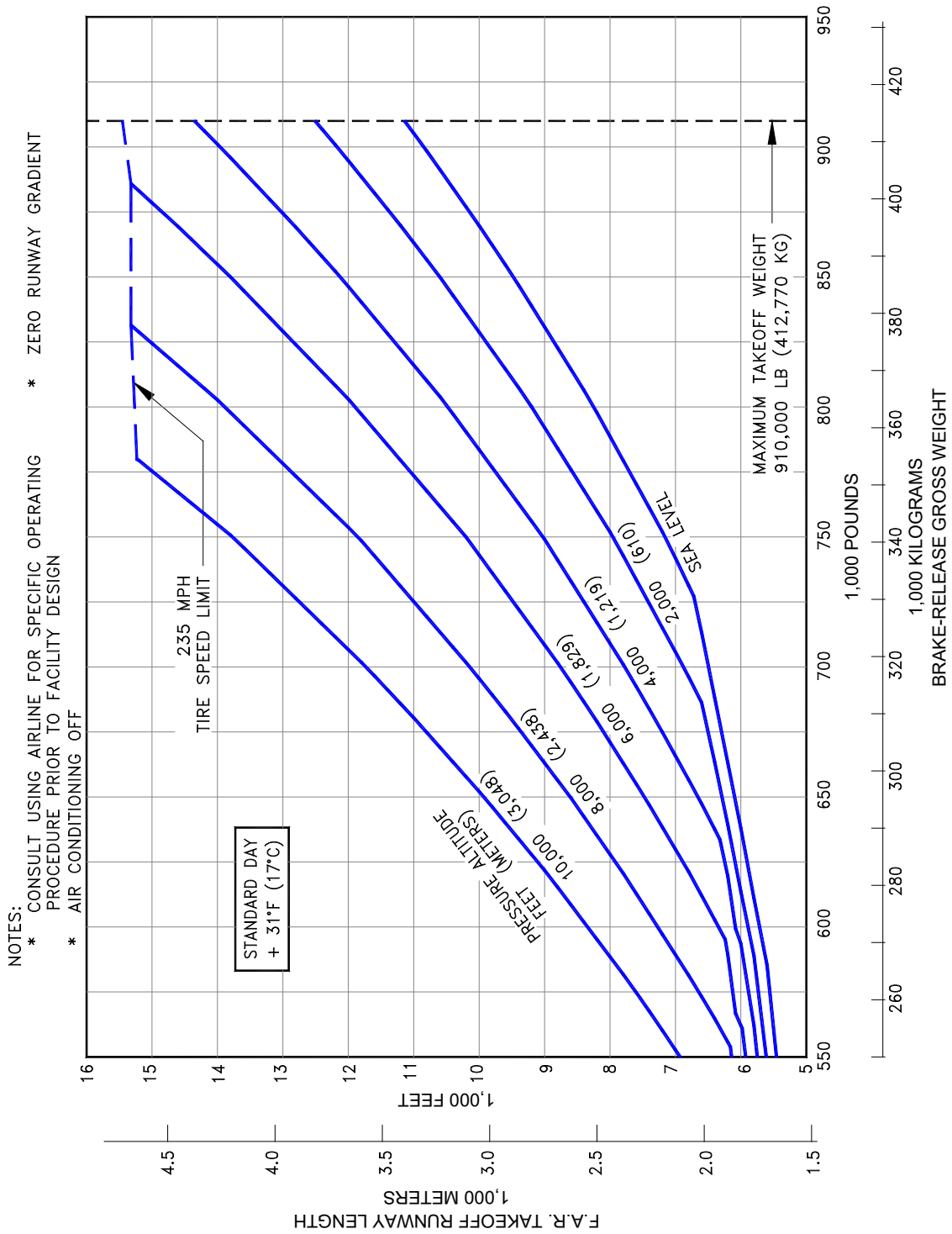

D6-58326-1

3.3.17 F.A.R. Takeoff Runway Length Requirements - Standard Day: Model 747-400ER Freighter (PW4062 Engines)

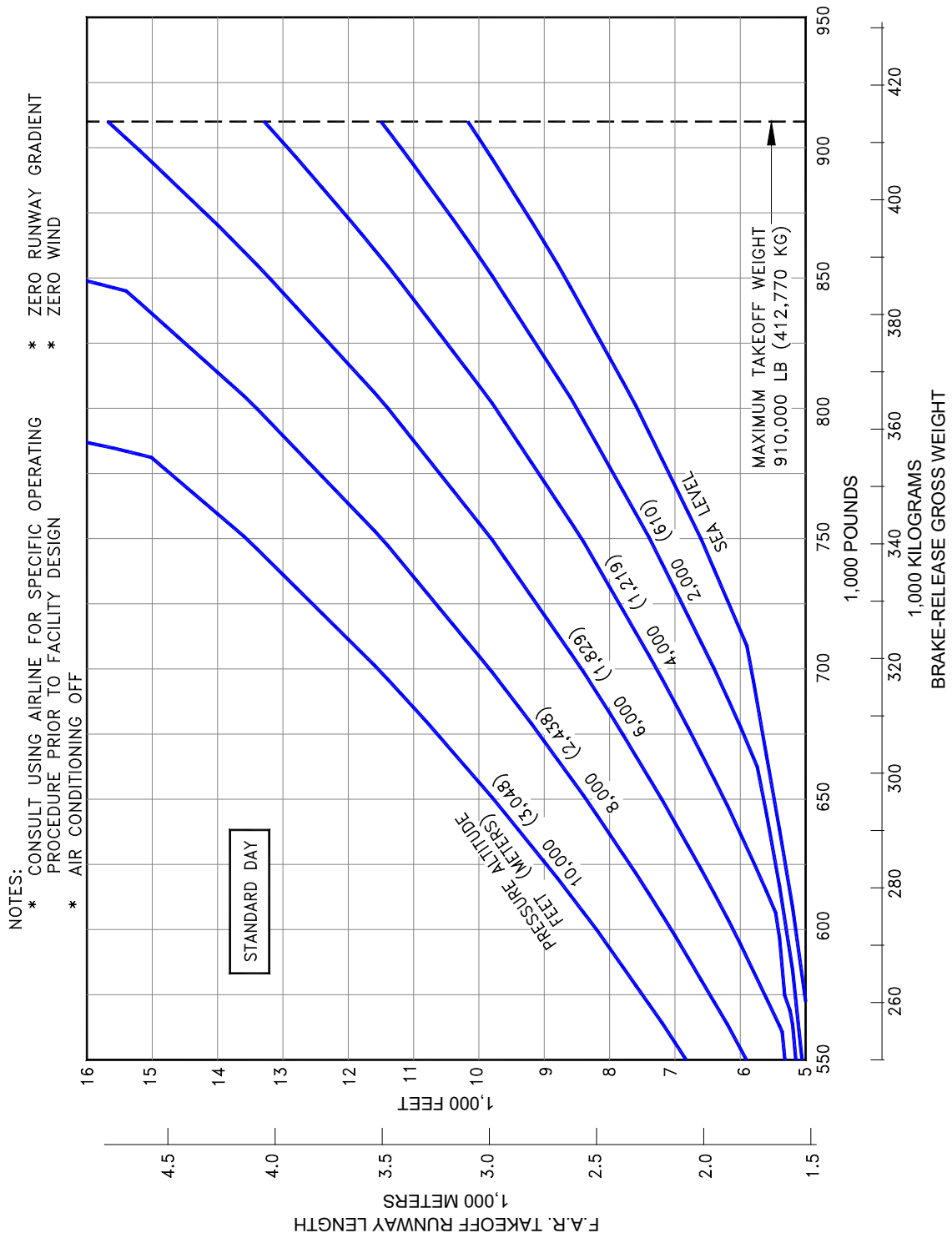

D6-58326-1

3.3.18 F.A.R. Takeoff Runway Length Requirements - Standard Day + 31°F (STD + 17°C): Model 747-400ER Freighter (PW4062 Engines)

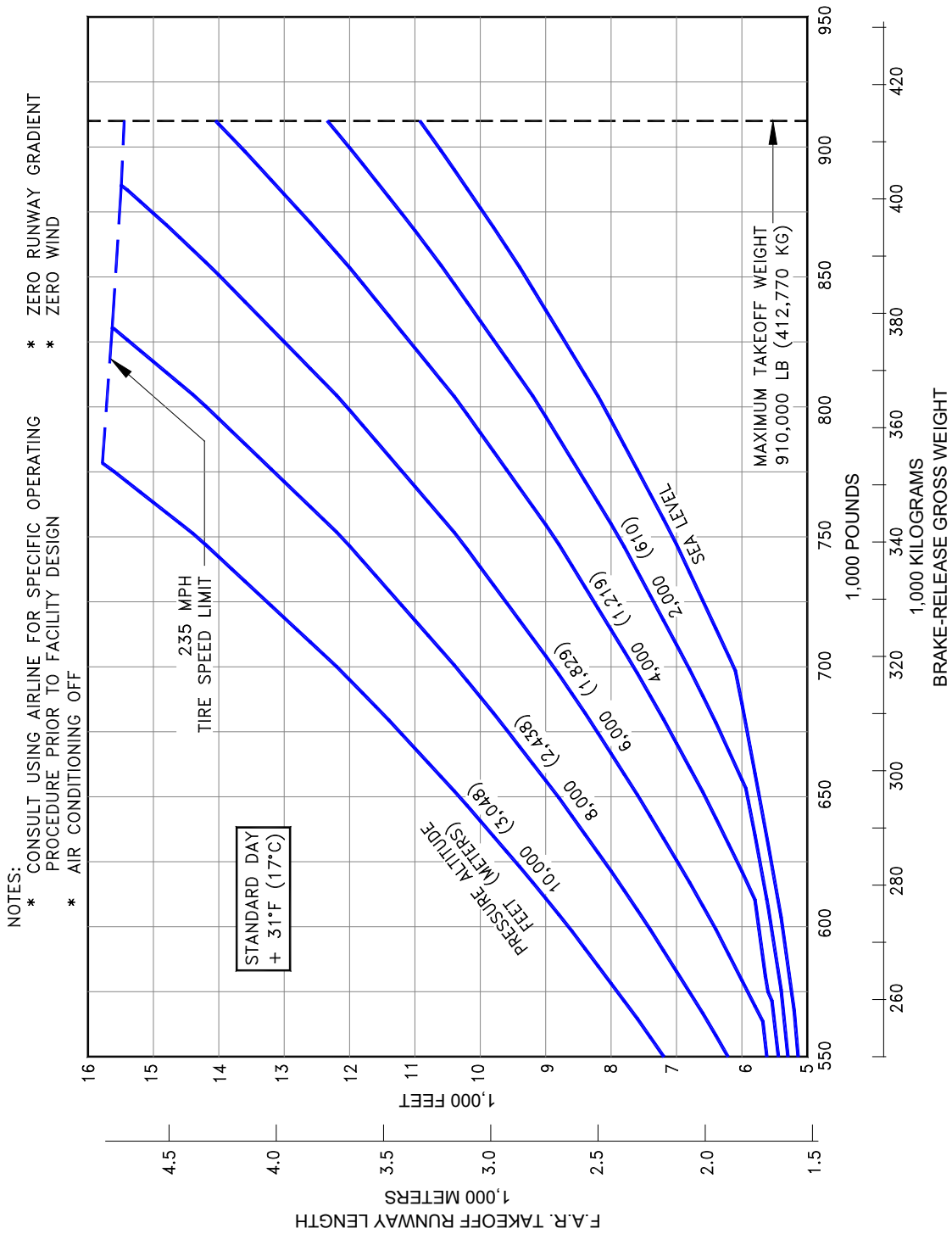

D6-58326-1

3.3.19 F.A.R. Takeoff Runway Length Requirements - Standard Day: Model 747-400ER Freighter (RB211-524H8-T Engines)

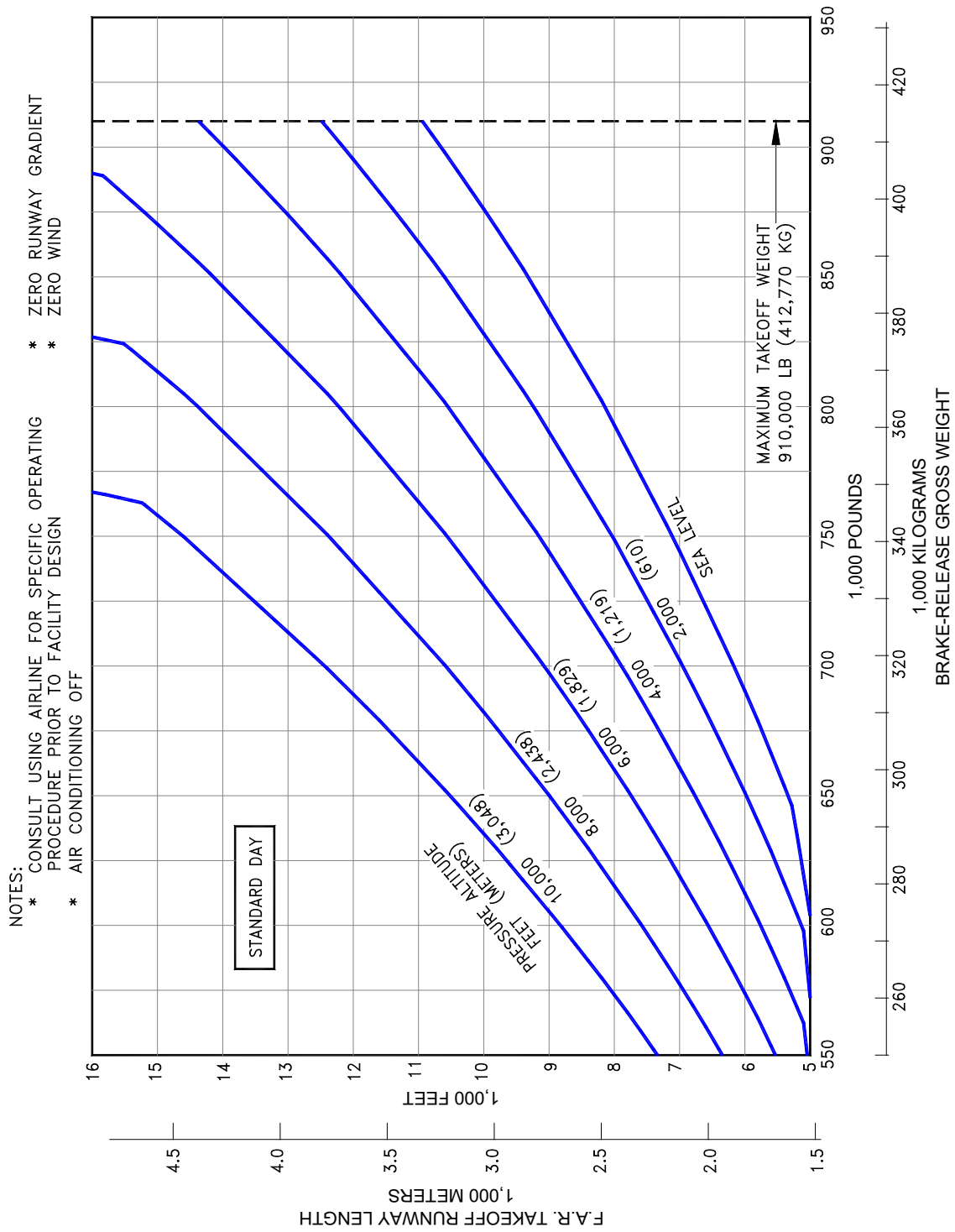

D6-58326-1

3.3.20 F.A.R. Takeoff Runway Length Requirements - Standard Day + 31°F (STD + 17°C): Model 747-400ER Freighter (RB211-524H8-T Engines)

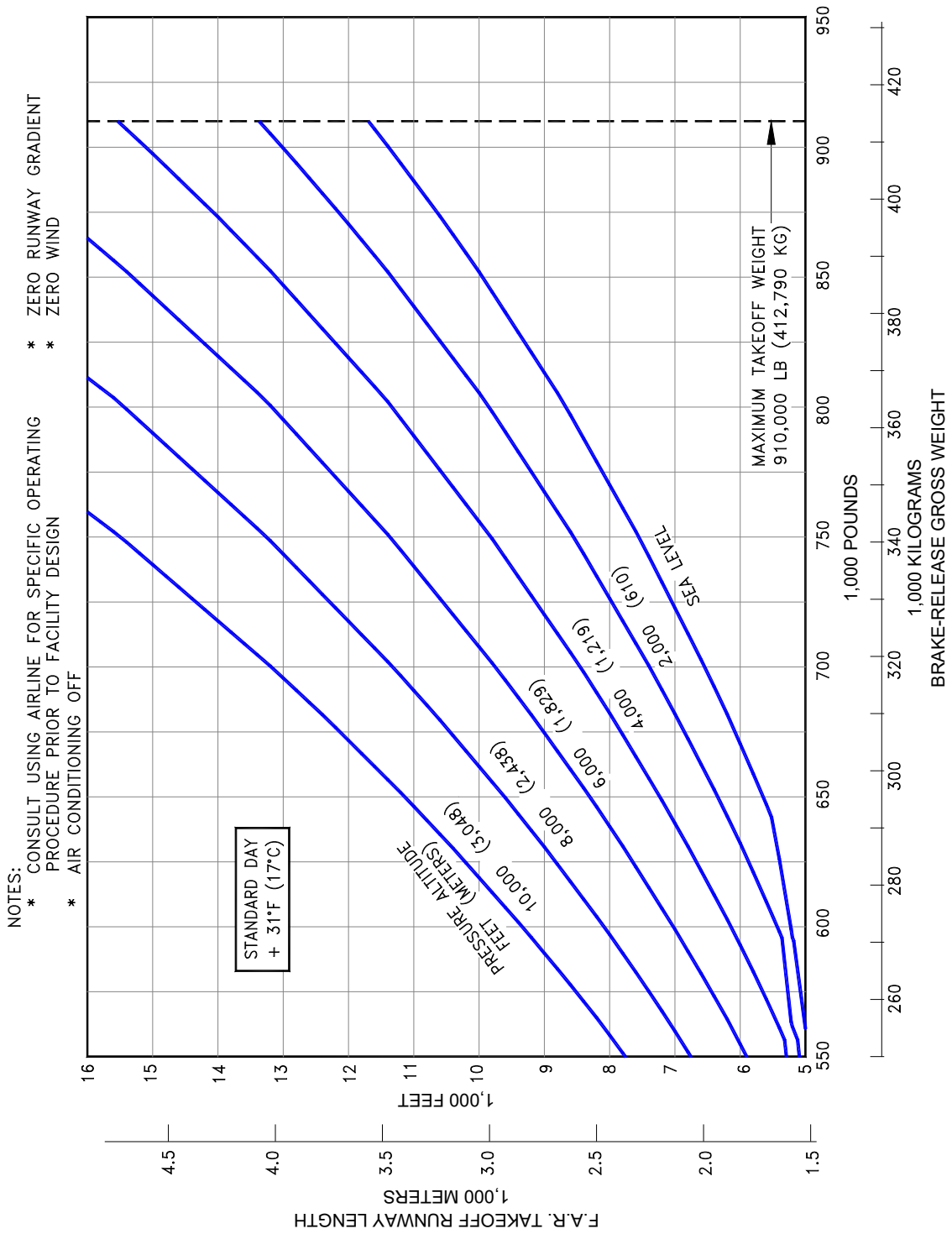

D6-58326-1

3.3.21 F.A.R. Takeoff Runway Length Requirements - Standard Day: Model 747-400 Domestic (CF6-80C2B1 Engines)

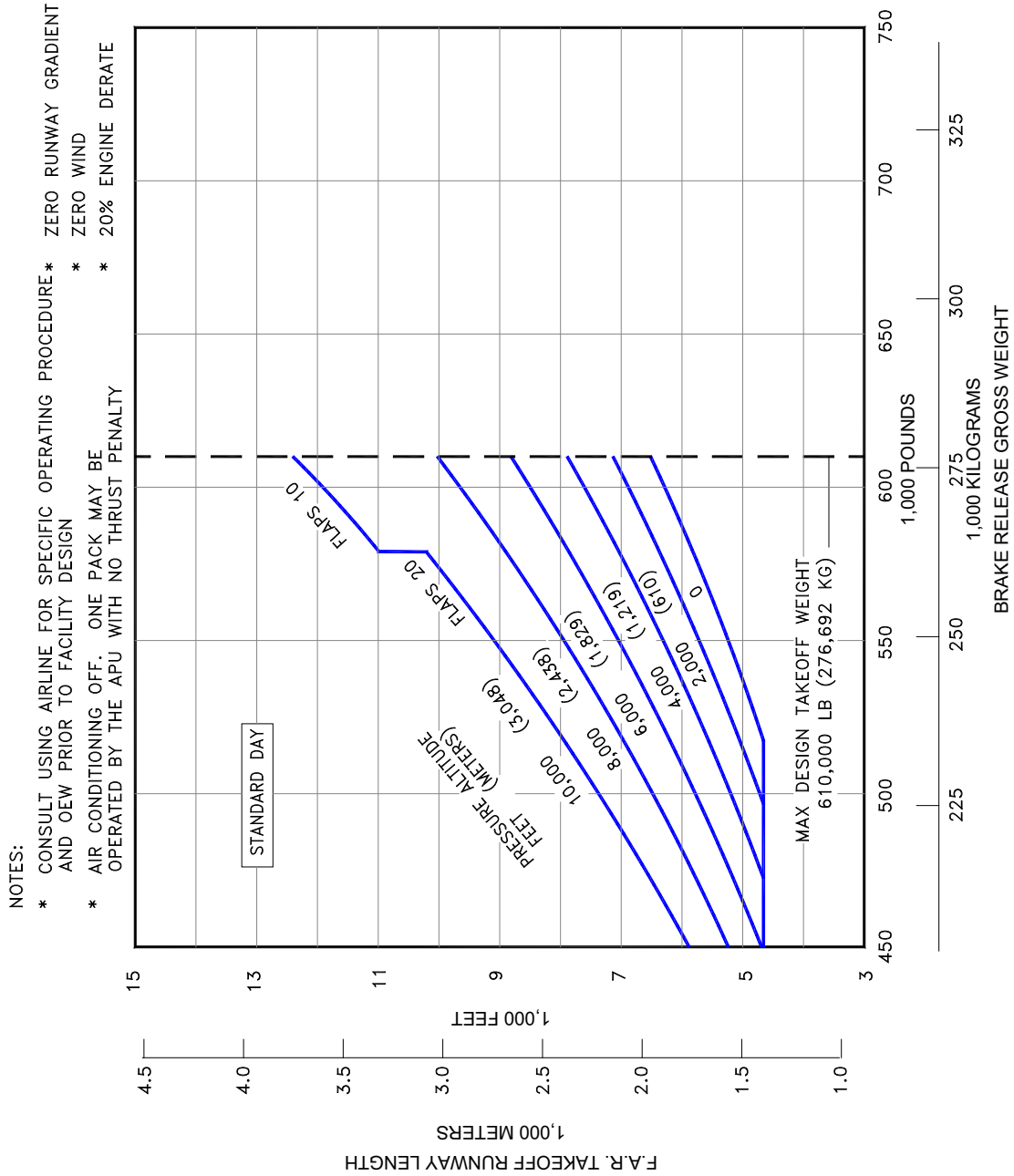

3.3.22 F.A.R. Takeoff Runway Length Requirements - Standard Day + 31°F (STD + 17.2°C): Model 747-400 Domestic (RB211-524H8-T Engines)

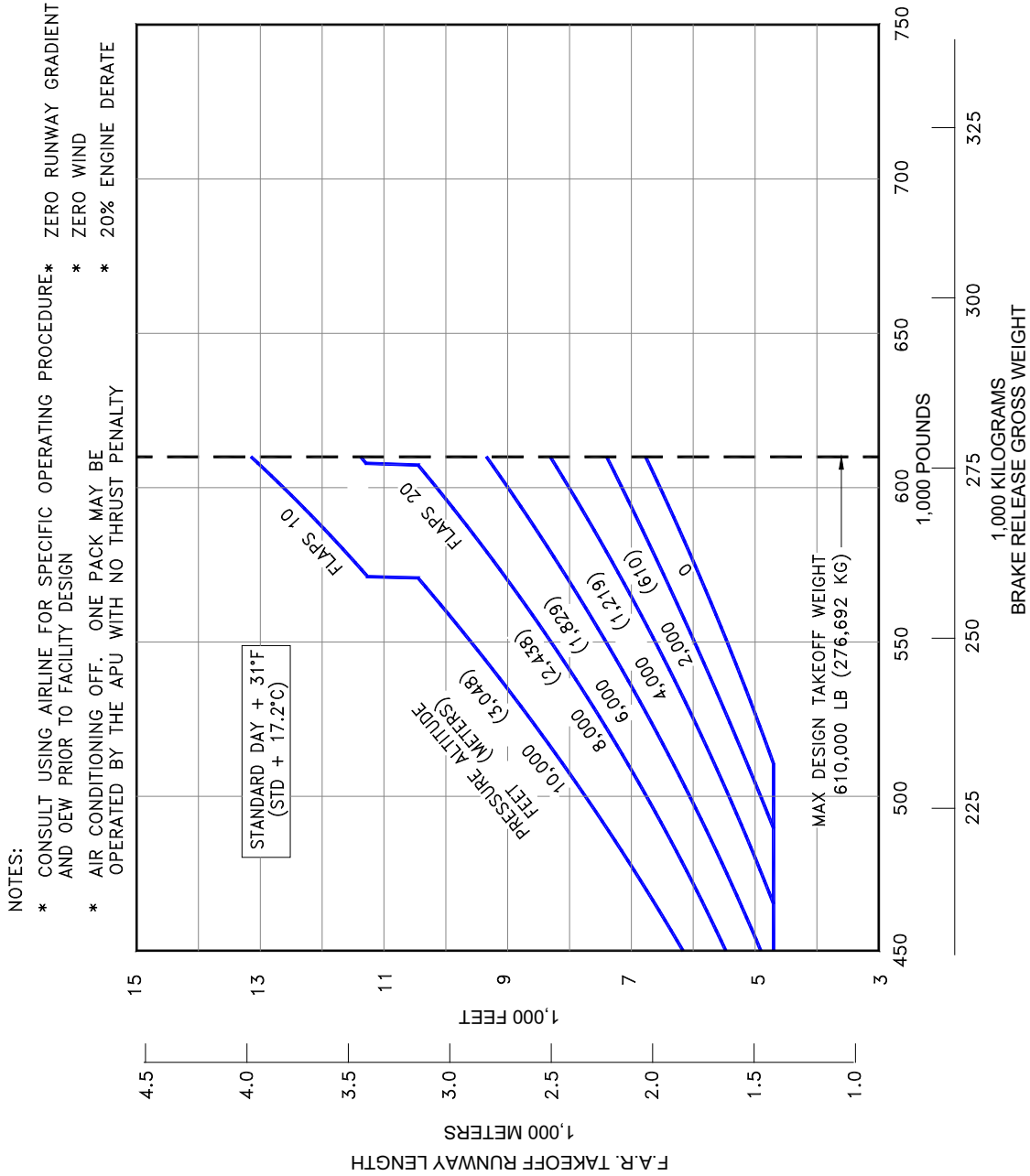

D6-58326-1

3.4 F.A.R. LANDING RUNWAY LENGTH REQUIREMENTS

3.4.1 F.A.R. Landing Runway Length Requirements - Flaps 25: Model 747-400, -400 Combi, -400 Domestic, -400 Freighter

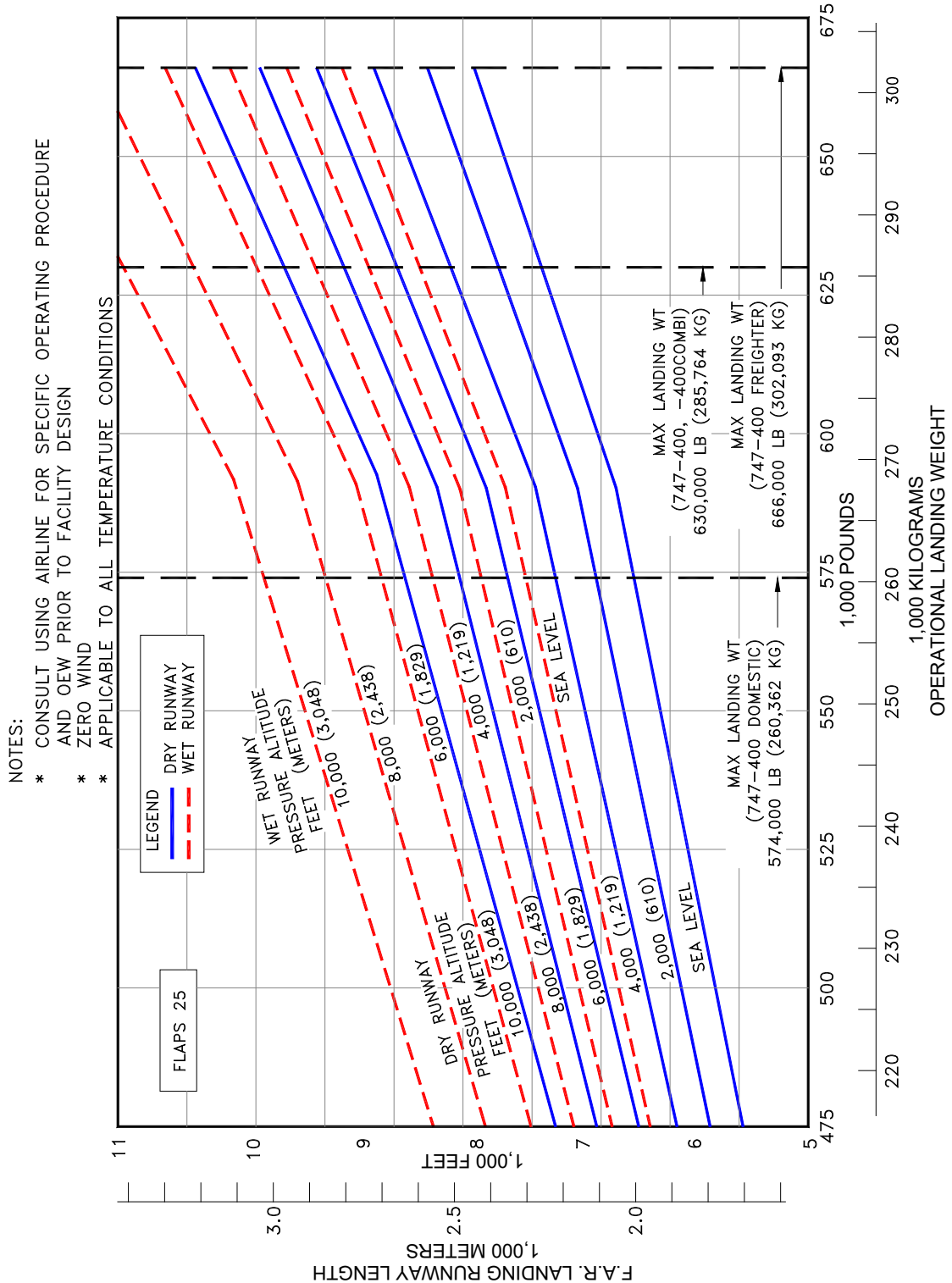

D6-58326-1

3.4.2 F.A.R. Landing Runway Length Requirements - Flaps 30: Model 747-400, -400 Combi, -400 Domestic, -400 Freighter

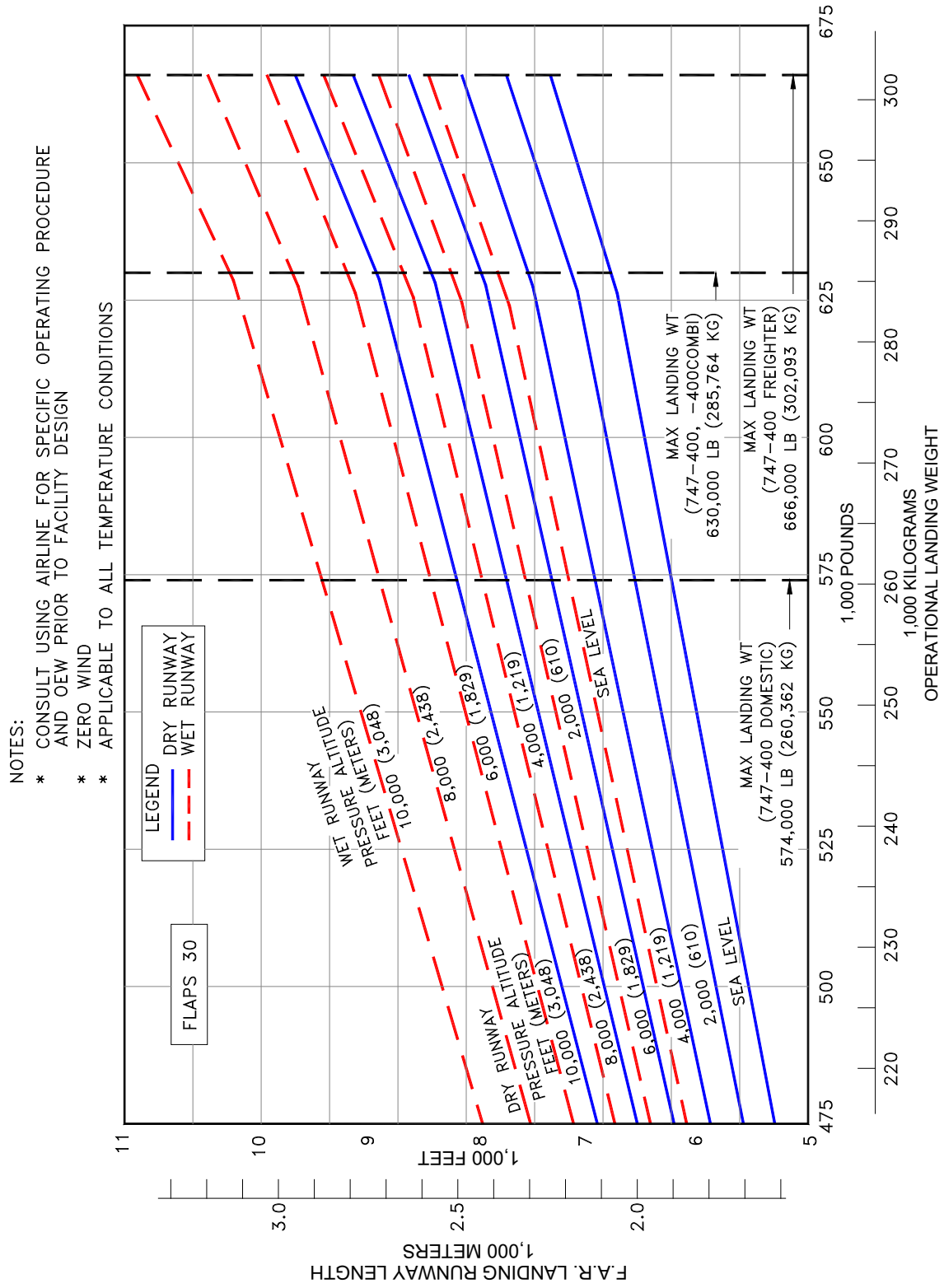

D6-58326-1

3.4.3 F.A.R. Landing Runway Length Requirements - Flaps 25: Model 747-400ER, -400ER Freighter

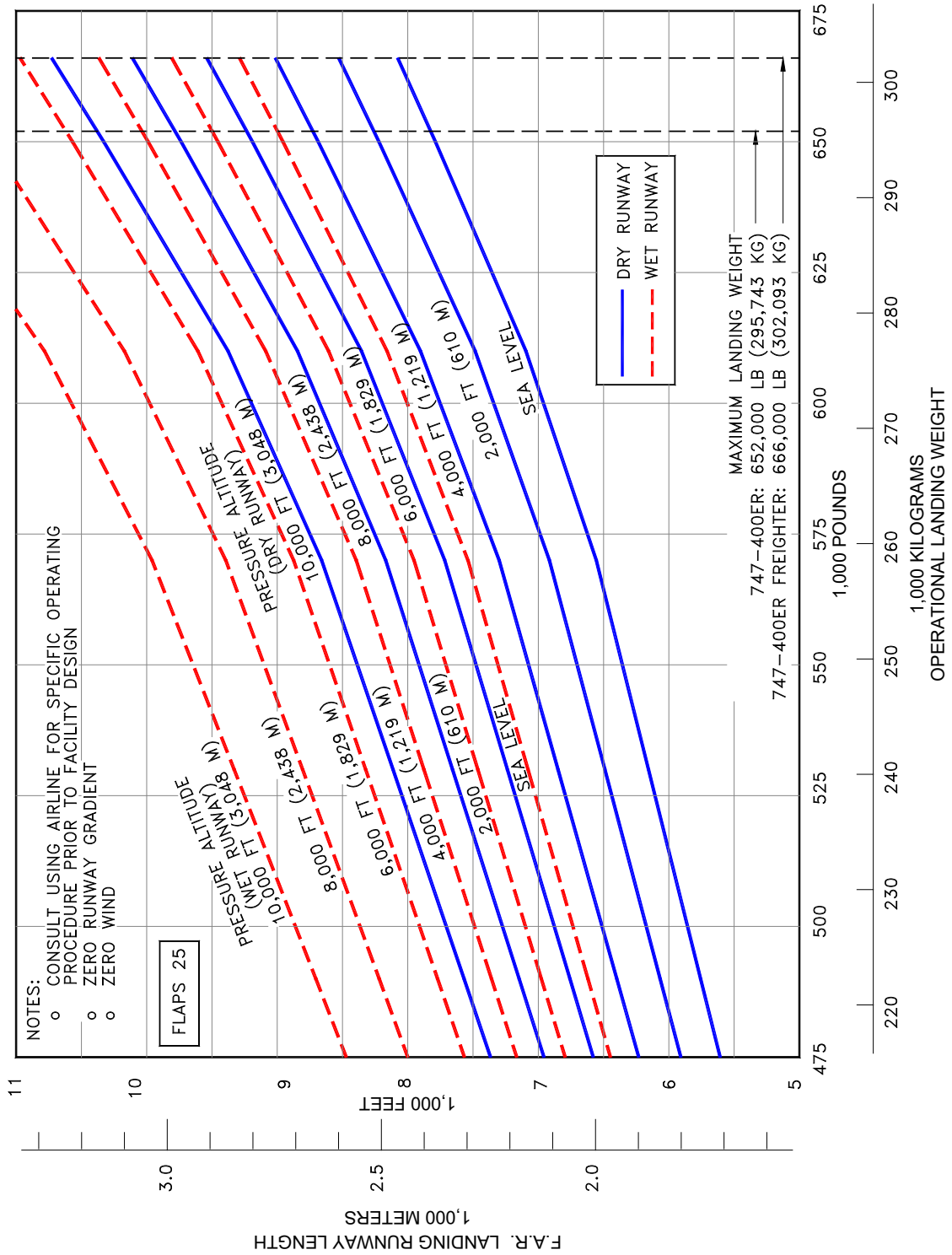

D6-58326-1

3.4.4 F.A.R. Landing Runway Length Requirements - Flaps 30: Model 747-400ER, -400ER Freighter

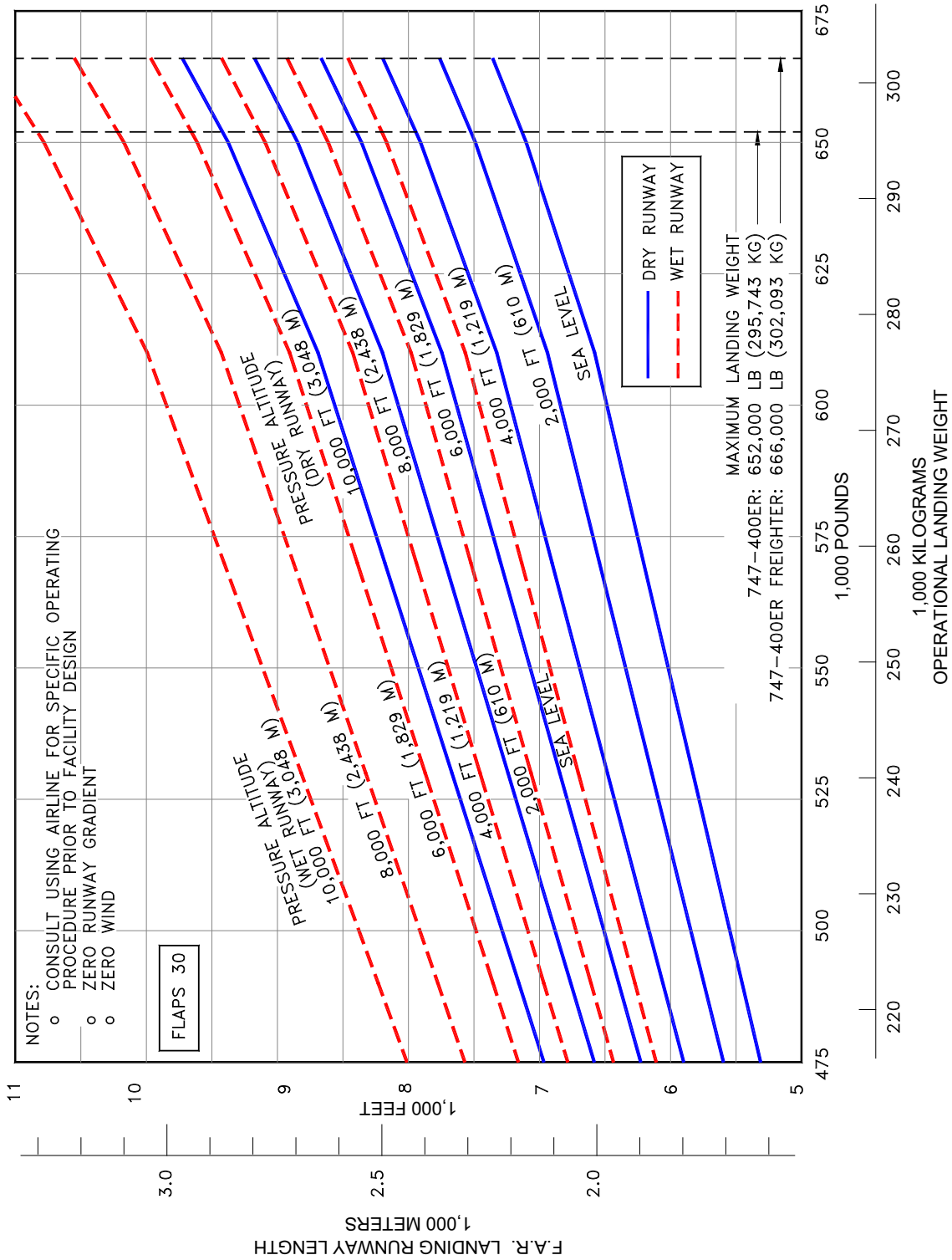

D6-58326-1

4.0 AIRPLANE PERFORMANCE

4.1 GENERAL INFORMATION

The 747 main landing gear consists of four main struts, each strut with four wheels. This geometric arrangement of the four main gears results in somewhat different ground maneuvering characteristics from those experienced with typical landing gear aircraft.

Basic factors that influence the geometry of the turn include:

1. Nose wheel steering angle
2. Engine power settings
3. Center of gravity location
4. Airplane weight
5. Pavement surface conditions
6. Amount of differential braking
7. Ground speed
8. Main landing gear steering

The steering system of the 747 incorporates steering of the main body landing gear in addition to the nose gear steering. This body gear steering system is hydraulically actuated and is programmed electrically to provide steering ratios proportionate to the nose gear steering angles. During takeoff and landing, the body gear steering system is centered, mechanically locked, and depressurized.

Steering of the main body gear has the following advantages over ground maneuvering without this steering feature; overall improved maneuverability, including improved nose gear tracking; elimination of the need for differential braking during ground turns, with subsequent reduced brake wear; reduced thrust requirements; lower main gear stress levels; and reduced tire scrubbing. The turning radii shown in Section 4.2 are derived from a previous test involving a 747-200. The 747-400 is expected to follow the same maneuvering characteristics.

This section provides airplane turning capability and maneuvering characteristics.

For ease of presentation, these data have been determined from the theoretical limits imposed by the geometry of the aircraft, and where noted, provide for a normal allowance for tire slippage. As such, they reflect the turning capability of the aircraft in favorable operating circumstances. These data should be used only as guidelines for the method of determination of such parameters and for the maneuvering characteristics of this aircraft.

In the ground operating mode, varying airline practices may demand that more conservative turning procedures be adopted to avoid excessive tire wear and reduce possible maintenance problems. Airline operating procedures will vary in the level of performance over a wide range of operating circumstances throughout the world. Variations from standard aircraft operating patterns may be necessary to satisfy physical constraints within the maneuvering area, such as adverse grades, limited area, or high risk of jet blast damage. For these reasons, ground maneuvering requirements should be coordinated with the using airlines prior to layout planning.

Section 4.2 presents turning radii for various nose gear steering angles. Radii for the main and nose gears are measured from the turn center to the outside of the tire.

Section 4.3 shows data on minimum width of pavement required for 180° turn.

Section 4.4 provides pilot visibility data from the cockpit and the limits of ambinocular vision through the windows. Ambinocular vision is defined as the total field of vision seen simultaneously by both eyes.

Section 4.5 shows approximate wheel paths for various runway and taxiway turn scenarios. The pavement fillet geometries are based on the FAA's Advisory Circular (AC) 150/5300-13 (thru change 16). They represent typical fillet geometries built at many airports worldwide. ICAO and other civil aviation authorities publish many different fillet design methods. Prior to determining the size of fillets, airports are advised to check with the airlines regarding the operating procedures and aircraft types they expect to use at the airport. Further, given the cost of modifying fillets and the operational impact to ground movement and air traffic during construction, airports may want to design critical fillets for larger aircraft types to minimize future operational impacts.

Section 4.6 illustrates a typical runway holding bay configuration.

4.1.1 General Information – Body Gear Steering System: Model 747

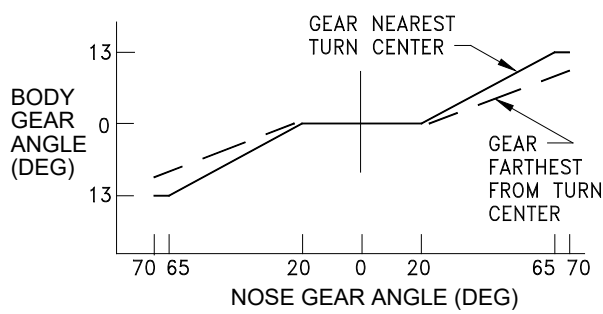
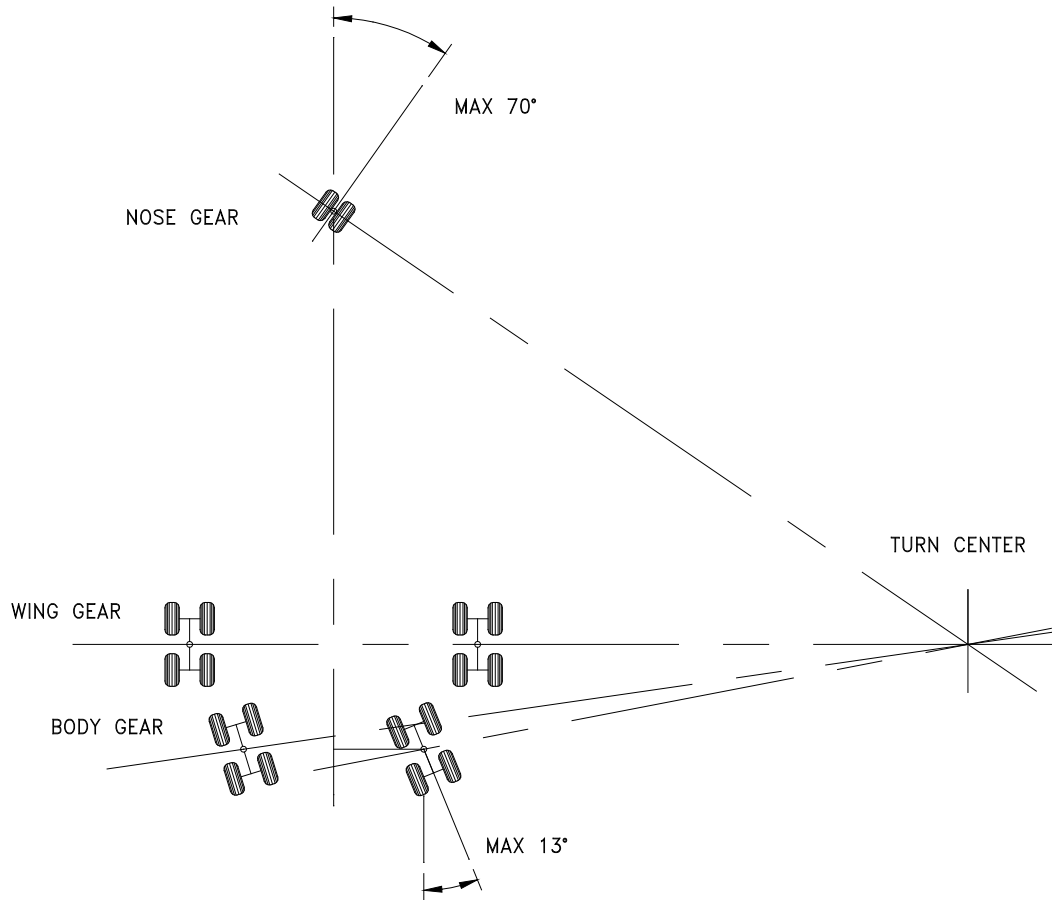

NOSE GEAR	BODY GEAR
0° TO 20°	0°
20° TO 70°	0° TO 13°

NOSEGEAR/BODY GEAR TURN RATIOS

4.2 TURNING RADII

4.2.1 Turning Radii – With Body Gear Steering - Symmetrical Thrust: Model 747

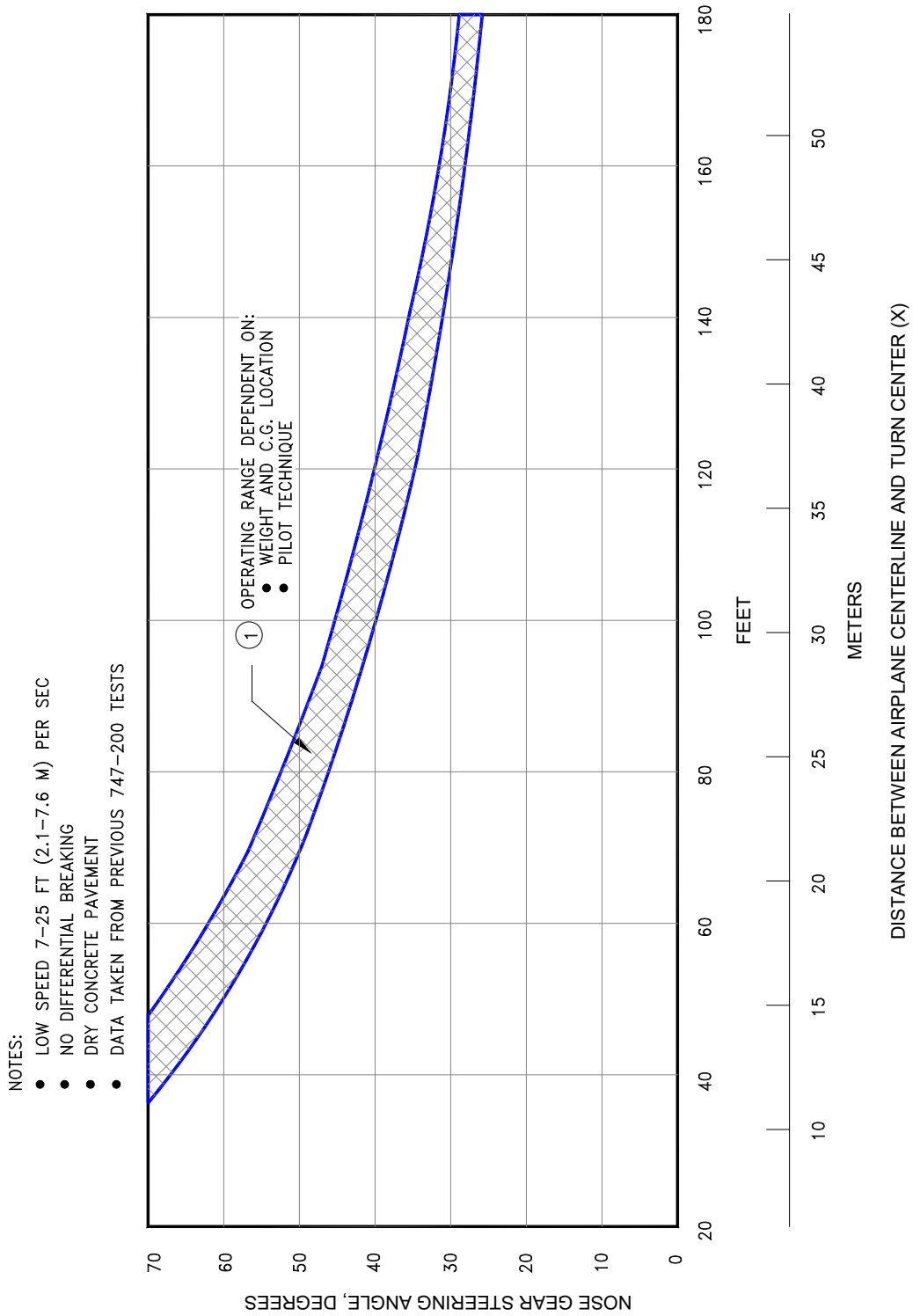

D6-58326-1

4.2.2 Turning Radii – Body Gear Steering Inoperative - Symmetrical Thrust: Model 747

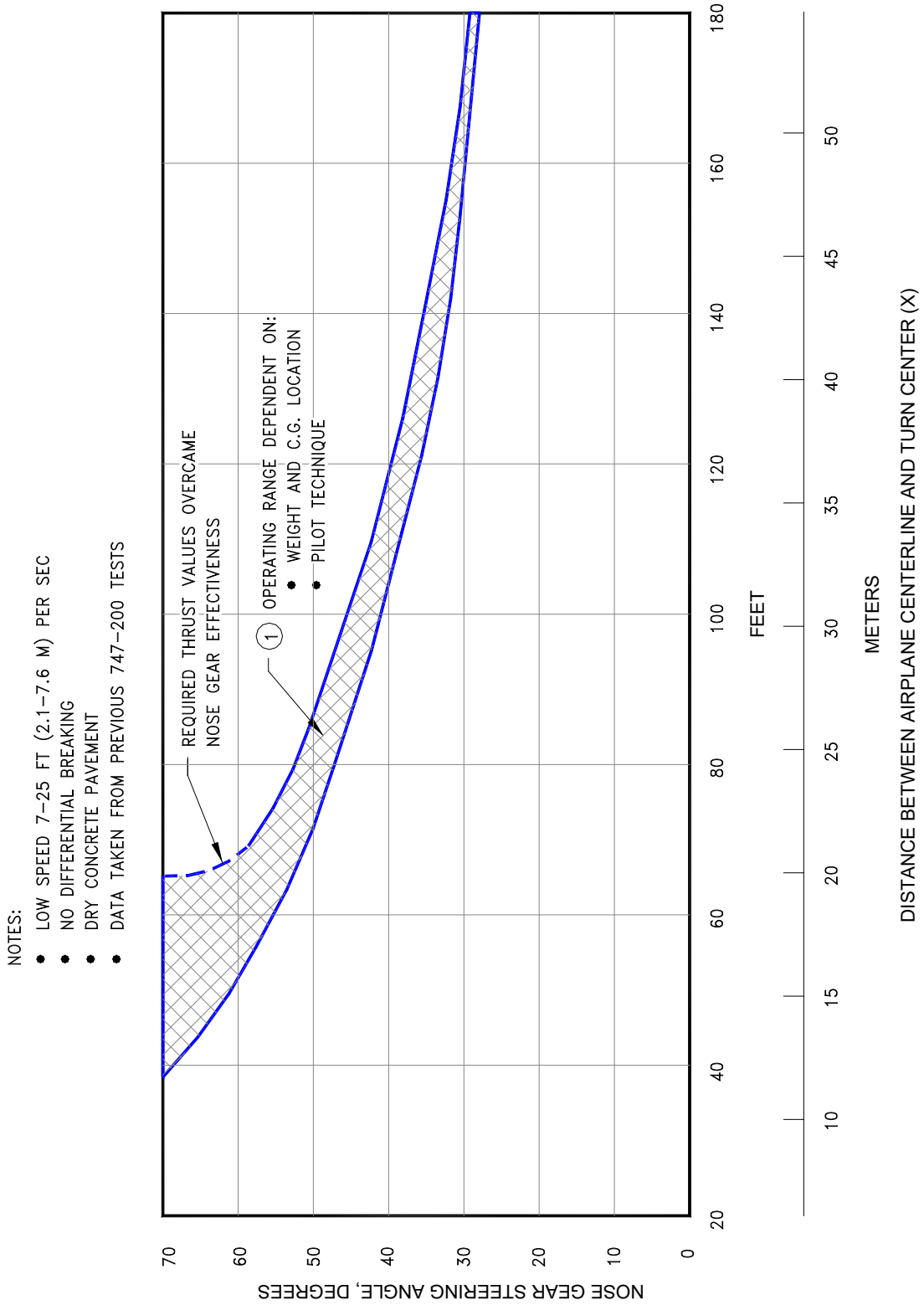

D6-58326-1

4.2.3 Turning Radii – With Body Gear Steering - Unsymmetrical Thrust: Model 747

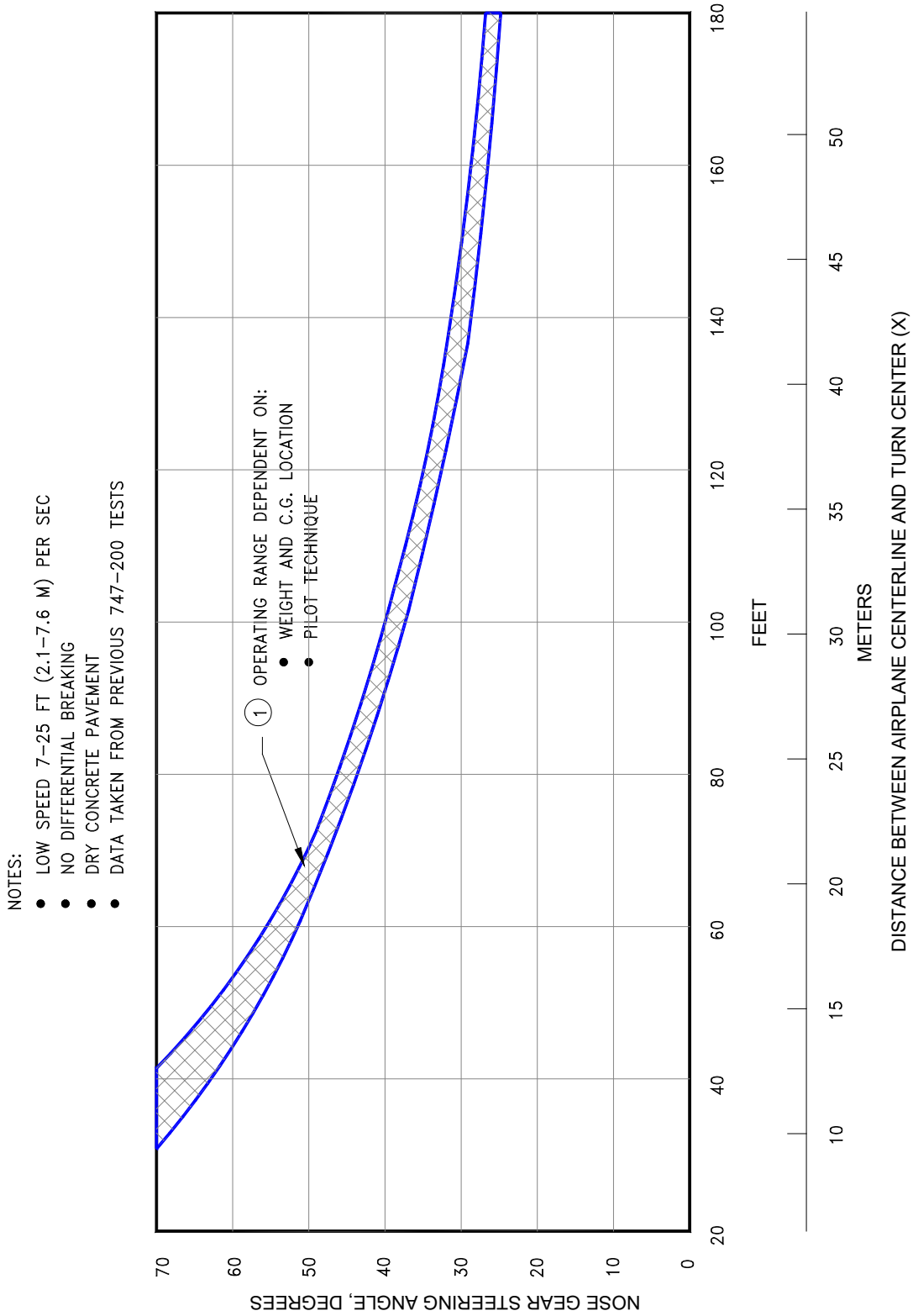

D6-58326-1

4.2.4 Turning Radii – Body Gear Steering Inoperative - Symmetrical Thrust: Model 747

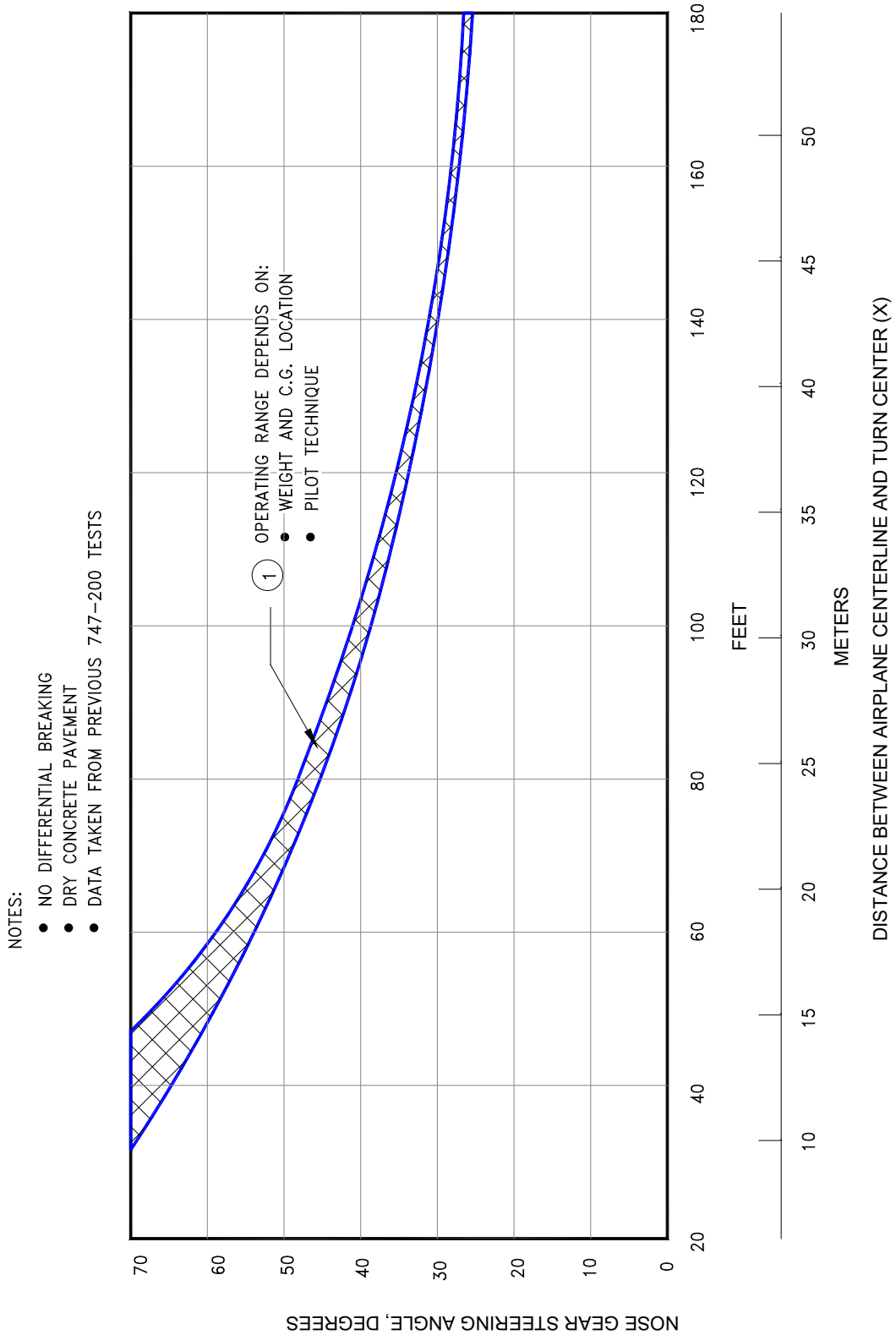

4.2.5 Turning Radii – Towed: Model 747

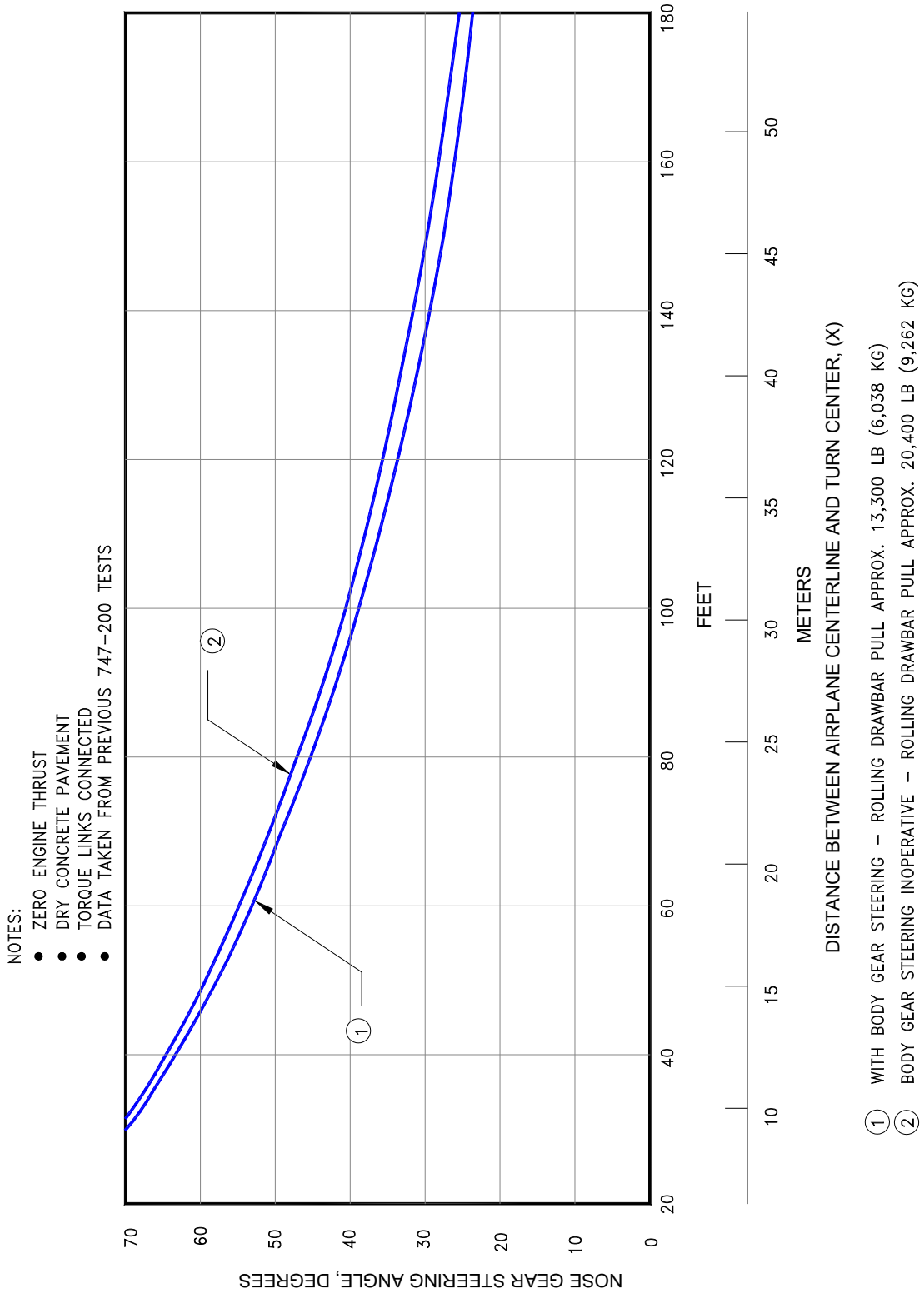

4.3 CLEARANCE RADII

4.3.1 Clearance Radii – English Units: Model 747-400, -400 Combi, -400 Freighter, -400ER, -400ER Freighter

- NOTES:** 1. CONSULT AIRLINE FOR OPERATING PROCEDURES
 2. VALUES ARE ROUNDED TO THE NEAREST FOOT

X * (FEET)	RADIUS (FEET)										Z (3) MINIMUM WIDTH FOR 180°TURN	
	A (4) WING TIP		B (3) NOSE GEAR		C (3) WING GEAR		D TAIL TIP		E NOSE		(1)	(2)
	(1)	(2)	(1)	(2)	(1)	(2)	(1)	(2)	(1)	(2)		
40	157	159	96	91	61	61	142	146	117	112	156	152
60	176	177	106	102	81	81	154	158	125	120	187	183
80	195	196	119	115	101	101	167	171	136	132	219	216
100	214	215	133	130	121	121	182	185	148	145	254	251
120	233	234	149	146	141	141	197	200	162	159	290	287
140	253	254	166	163	161	161	213	216	178	175	327	324
160	272	273	183	181	181	181	230	233	194	191	364	362

* X = DISTANCE BETWEEN AIRPLANE CENTERLINE AND TURN CENTER

- (1) BODY GEAR STEERING INOPERATIVE
- (2) WITH BODY GEAR STEERING
- (3) MEASURED TO OUTSIDE TIRE FACES
- (4) WINGSPAN AT 213 FEET

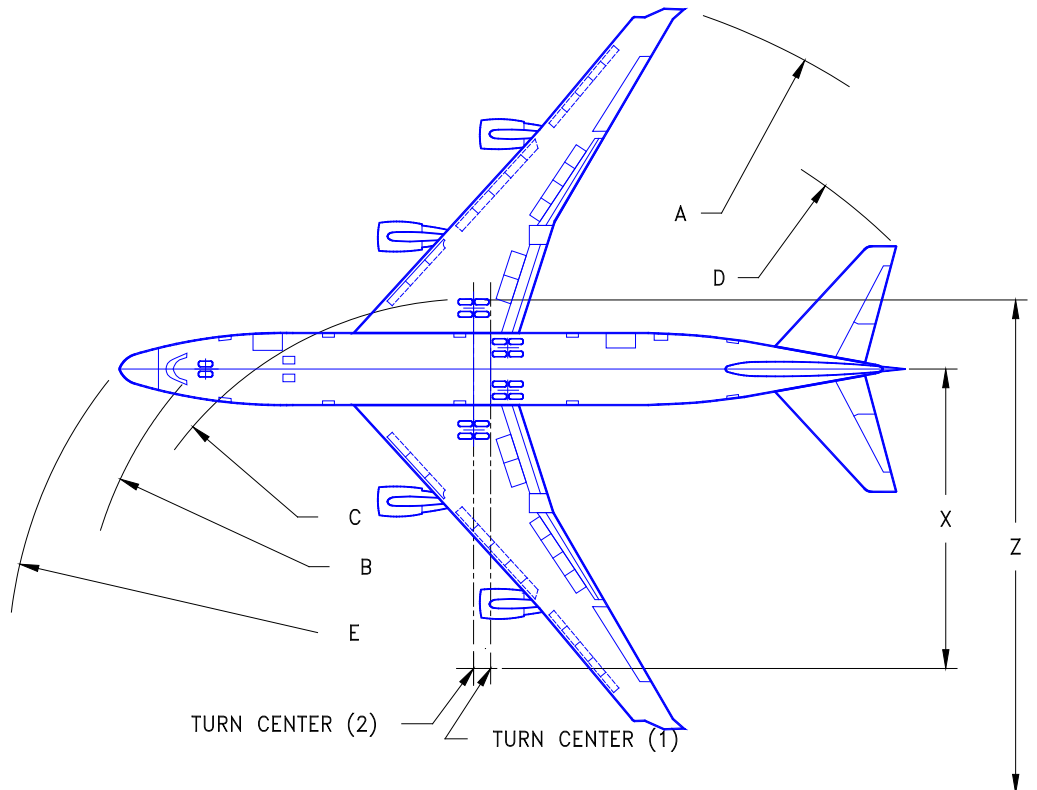

D6-58326-1

4.3.2 Clearance Radii – Metric Units: Model 747-400, -400 Combi, -400 Freighter, -400ER, -400ER Freighter

- NOTES:** 1. CONSULT AIRLINE FOR OPERATING PROCEDURES
 2. VALUES ARE ROUNDED TO THE NEAREST 0.1 METER

X * (METERS)	RADIUS (FEET)										Z (3) MINIMUM WIDTH FOR 180°TURN (METERS)	
	A (4) WING TIP		B (3) NOSE GEAR		C (3) WING GEAR		D TAIL TIP		E NOSE		(1)	(2)
	(1)	(2)	(1)	(2)	(1)	(2)	(1)	(2)	(1)	(2)		
15	50.4	50.9	30.5	29.2	21.3	21.3	44.9	46.1	36.6	35.2	51.8	50.5
20	55.1	55.6	33.3	32.1	26.3	26.3	48.0	49.1	38.9	37.6	59.6	58.4
25	59.9	60.3	36.6	35.5	31.3	31.3	51.3	52.4	41.7	40.5	67.9	66.8
30	64.7	65.1	40.2	39.3	36.3	36.3	55.0	56.0	44.9	43.7	76.5	75.6
35	69.5	69.9	44.2	43.3	41.3	41.3	58.8	59.8	48.3	47.3	85.5	84.6
40	74.4	74.8	48.3	47.5	46.3	46.3	62.8	63.7	52.1	51.1	94.6	93.8
45	79.3	79.6	52.6	51.8	51.3	51.3	66.9	67.8	56.0	55.1	103.9	103.1

* X = DISTANCE BETWEEN AIRPLANE CENTERLINE AND TURN CENTER

- (1) BODY GEAR STEERING INOPERATIVE
- (2) WITH BODY GEAR STEERING
- (3) MEASURED TO OUTSIDE TIRE FACES
- (4) WINGSPAN AT 64.9 METERS

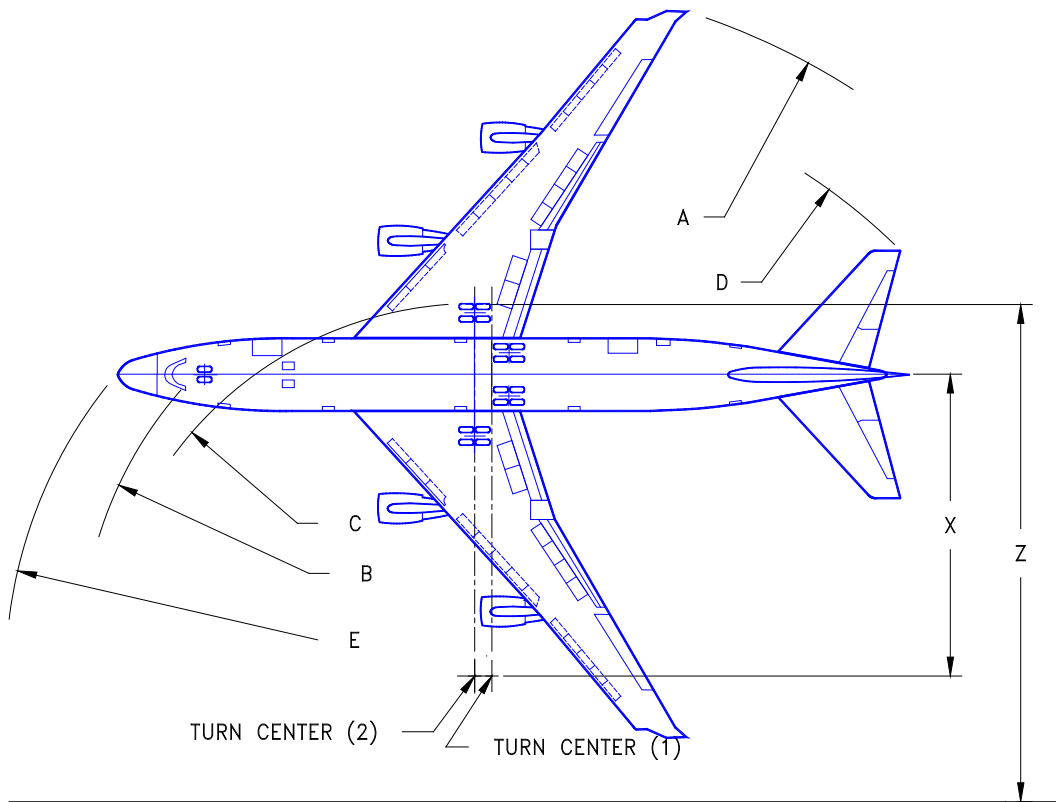

D6-58326-1

REV E

September 2023

4-10

4.3.3 Clearance Radii – English Units: Model 747-400 Domestic

NOTES: 1. CONSULT AIRLINE FOR OPERATING PROCEDURES

X * (FEET)	RADIUS (FEET)										Z (3) MINIMUM WIDTH FOR 180°TURN	
	A (4) WING TIP		B (3) NOSE GEAR		C (3) WING GEAR		D TAIL TIP		E NOSE		(1)	(2)
	(1)	(2)	(1)	(2)	(1)	(2)	(1)	(2)	(1)	(2)		
40	148	151	96	91	61	61	142	146	117	112	156	152
60	168	170	106	102	81	81	154	158	125	120	187	183
80	187	188	119	115	101	101	167	171	136	132	219	216
100	206	207	133	130	121	121	182	185	148	145	254	251
120	225	226	149	146	141	141	197	200	162	159	290	287
140	245	246	166	163	161	161	213	216	178	175	327	324
160	264	265	183	181	181	181	230	233	194	191	364	362

* X = DISTANCE BETWEEN AIRPLANE CENTERLINE AND TURN CENTER

- (1) BODY GEAR STEERING INOPERATIVE
- (2) WITH BODY GEAR STEERING
- (3) MEASURED TO OUTSIDE TIRE FACES

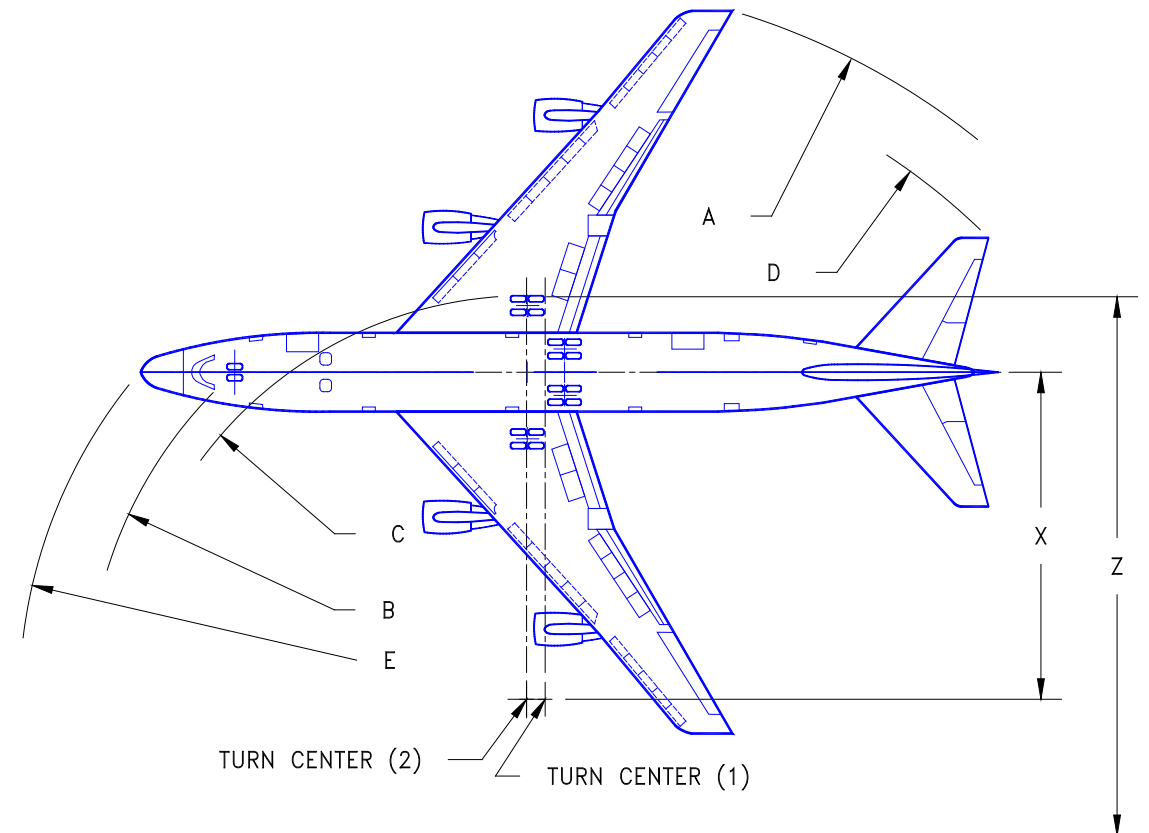

D6-58326-1

REV E

September 2023

4-11

4.3.4 Clearance Radii – Metric Units: Model 747-400 Domestic

NOTES: 1. CONSULT AIRLINE FOR OPERATING PROCEDURES

X * (METERS)	RADIUS (FEET)										Z (3) MINIMUM WIDTH FOR 180°TURN (METERS)	
	A (4) WING TIP		B (3) NOSE GEAR		C (3) WING GEAR		D TAIL TIP		E NOSE		(1)	(2)
	(1)	(2)	(1)	(2)	(1)	(2)	(1)	(2)	(1)	(2)		
15	48.2	48.8	30.5	29.2	21.3	21.3	44.9	46.1	36.6	35.2	51.8	50.5
20	52.7	53.3	33.3	32.1	26.3	26.3	48.0	49.1	38.9	37.6	59.6	58.4
25	57.6	59.7	36.6	35.5	31.3	31.3	51.3	52.4	41.7	40.5	67.9	66.8
30	62.2	62.8	40.2	39.3	36.3	36.3	55.0	56.0	44.9	43.7	76.5	75.6
35	67.1	67.7	44.2	43.3	41.3	41.3	58.8	59.8	48.3	47.3	85.5	84.6
40	71.9	72.2	48.3	47.5	46.3	46.3	62.8	63.7	52.1	51.1	94.6	93.8
45	76.8	77.1	52.6	51.8	51.3	51.3	66.9	67.8	56.0	55.1	103.9	103.1

* X = DISTANCE BETWEEN AIRPLANE CENTERLINE AND TURN CENTER

- (1) BODY GEAR STEERING INOPERATIVE
- (2) WITH BODY GEAR STEERING
- (3) MEASURED TO OUTSIDE TIRE FACES

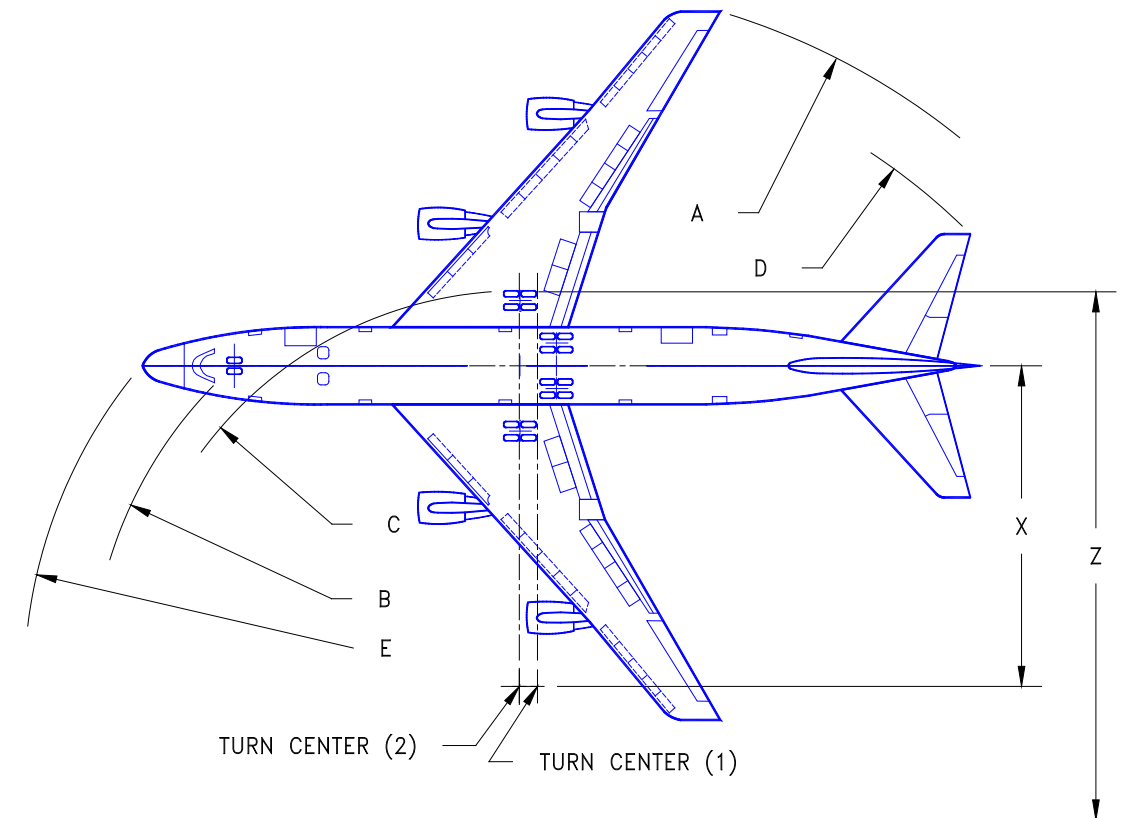

4.4 VISIBILITY FROM COCKPIT IN STATIC POSITION: MODEL 747-400

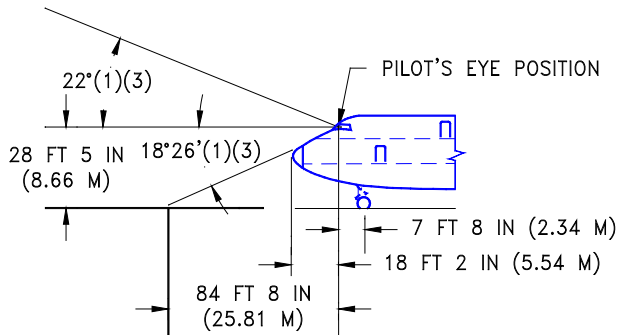

NOT TO BE USED FOR
LANDING APPROACH
VISIBILITY

VISUAL ANGLES IN VERTICAL PLANE
THROUGH PILOT'S EYE POSITION

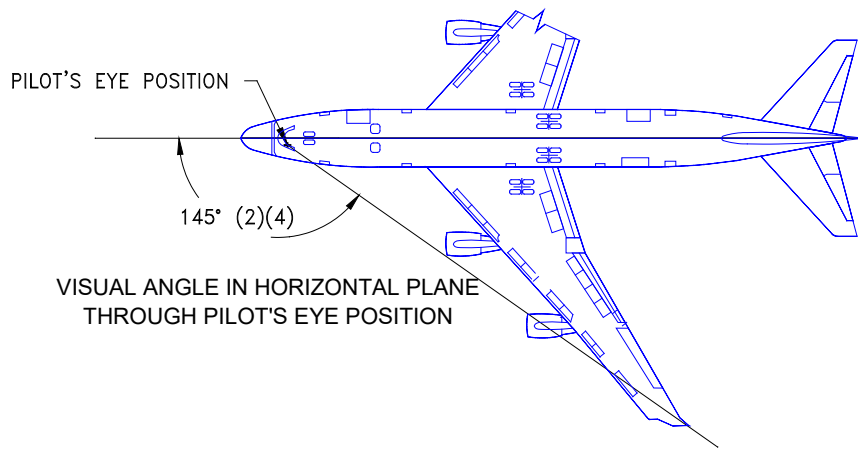

VISUAL ANGLE IN HORIZONTAL PLANE
THROUGH PILOT'S EYE POSITION

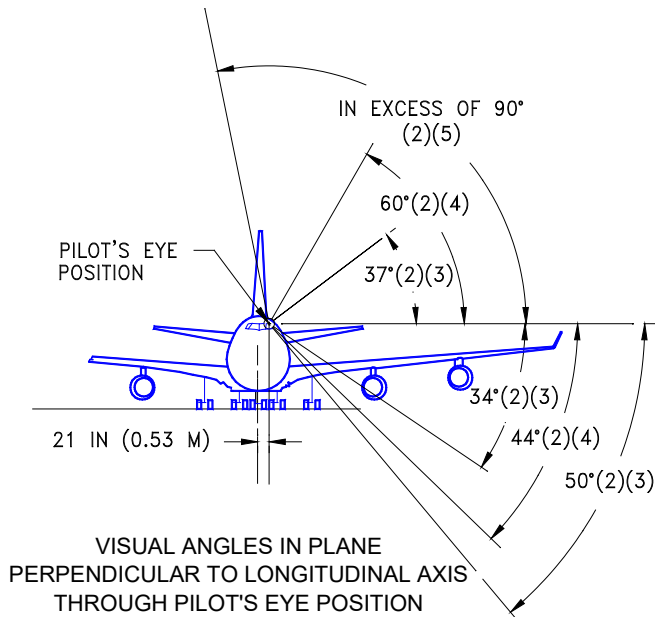

VISUAL ANGLES IN PLANE
PERPENDICULAR TO LONGITUDINAL AXIS
THROUGH PILOT'S EYE POSITION

NOTES:

- (1) VISUAL ANGLES THROUGH WINDSHIELD
- (2) VISUAL ANGES THROUGH SIDE WINDOW
- (3) VISUAL ANGLES FROM NORMAL POSITION
- (4) VISUAL ANGLES FROM ALERT POSITION, HEAD MOVED OUTBOARD 5 IN (0.13 M)
- (5) VISUAL ANGLES WITH HEAD MOVED 7 IN (0.18 M) OUTBOARD
- * HEAD IS ROTATED ABOUT A POINT 3 IN (0.08 M) AFT OF PILOT'S EYE POSITION

4.5 RUNWAY AND TAXIWAY TURN PATHS

4.5.1 Runway and Taxiway Turnpaths - Runway-to-Taxiway, 90 Degrees: Model 747-400

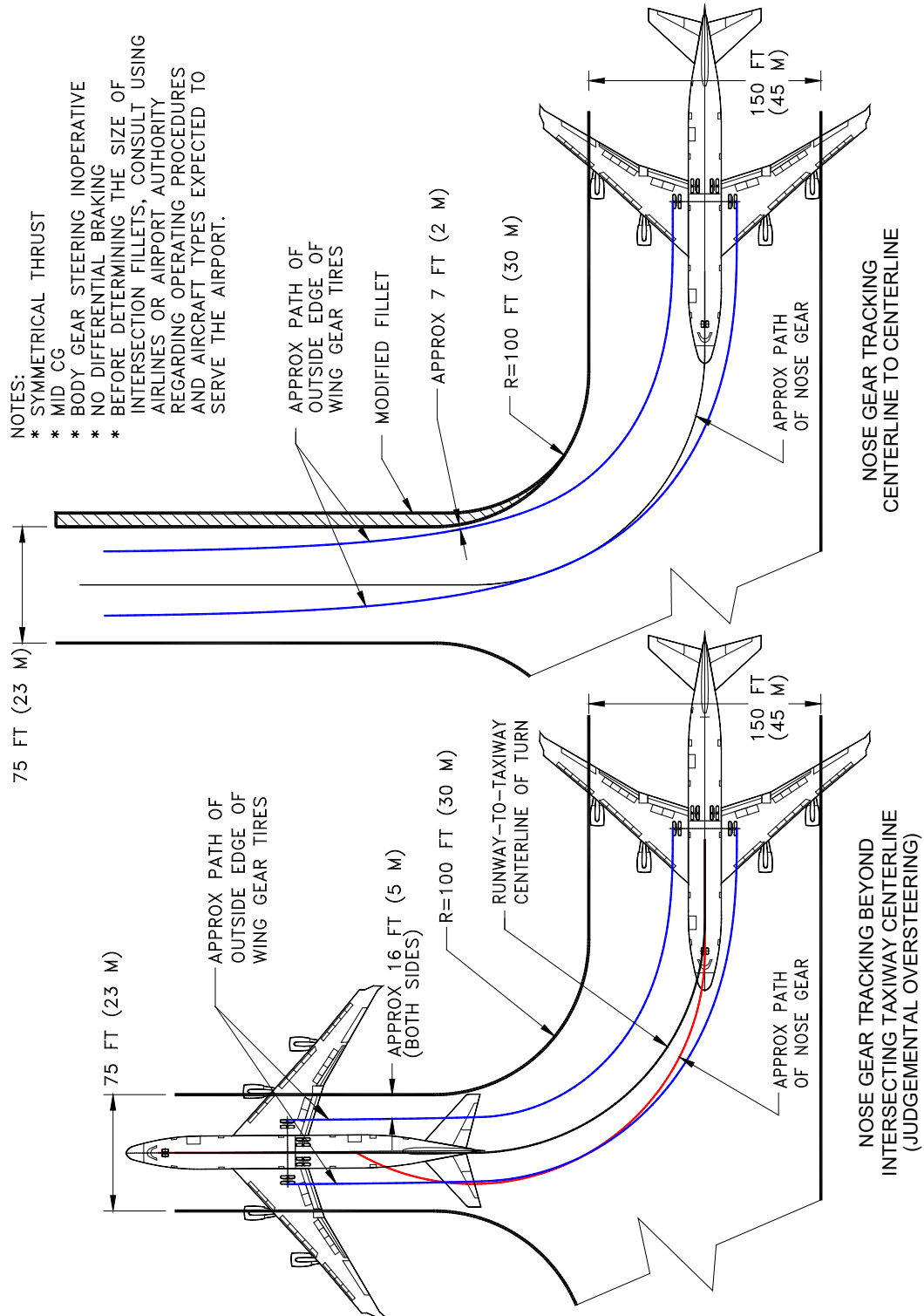

D6-58326-1

4.5.2 Runway and Taxiway Turnpaths - Runway-to-Taxiway, More Than 90 Degrees, Nose Gear Tracks Centerline: Model 747-400

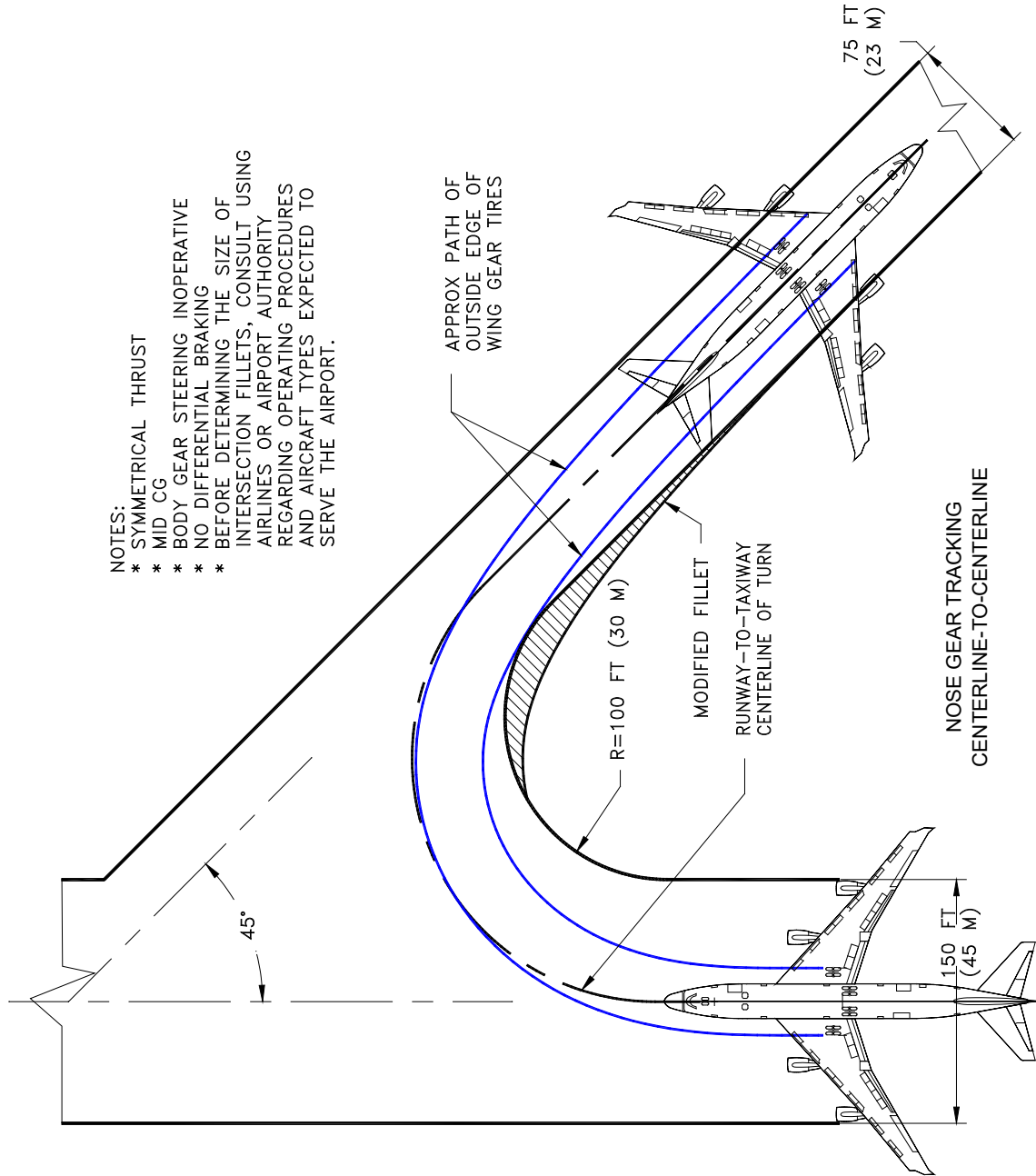

D6-58326-1

4.5.3 Runway and Taxiway Turnpaths - Runway-to-Taxiway, More Than 90 Degrees, Judgmental Oversteering: Model 747-400

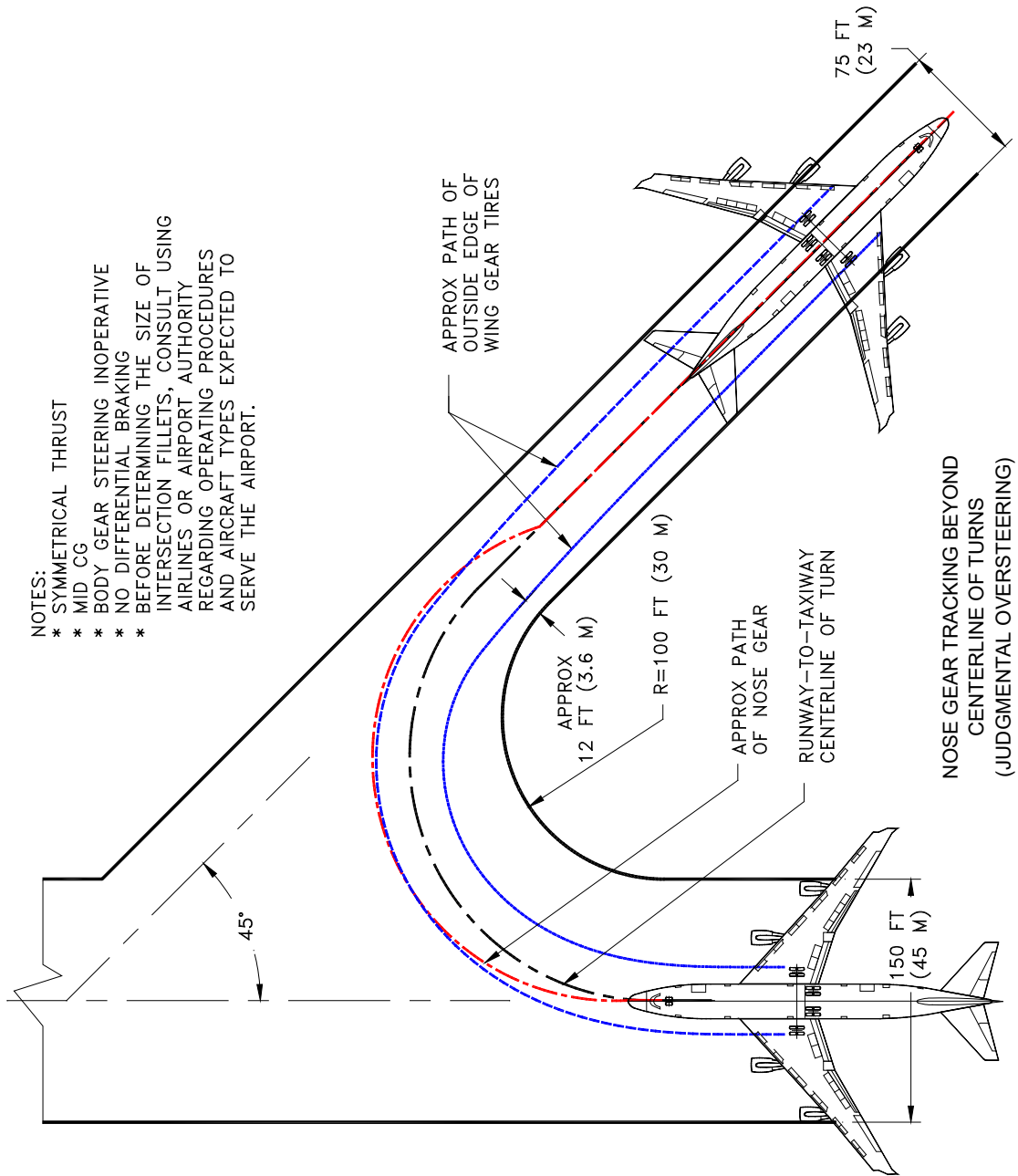

D6-58326-1

4.5.4 Runway and Taxiway Turnpaths - Taxiway-to-Taxiway, 90 Degrees: Model 747-400

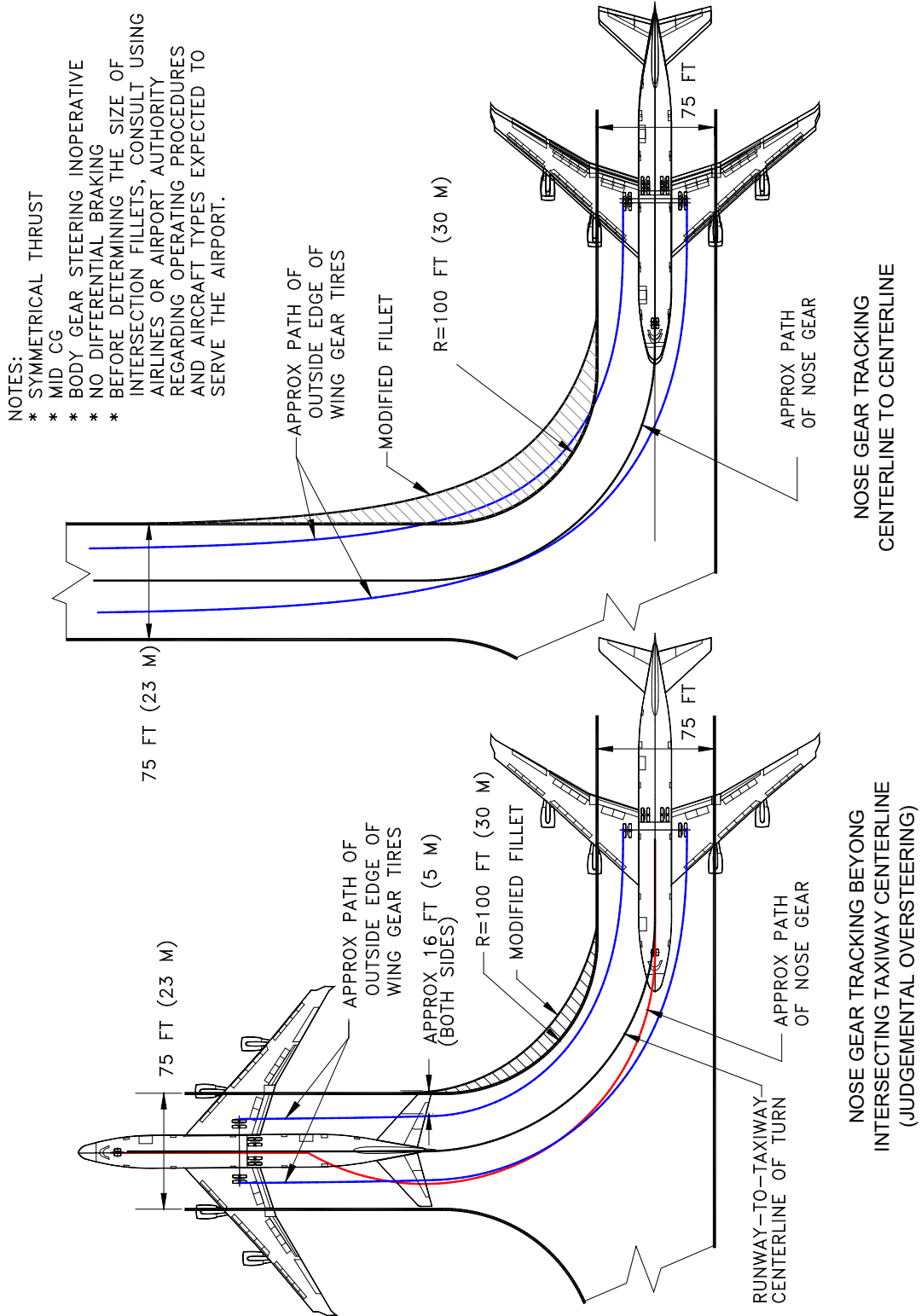

D6-58326-1

4.5.5 Runway and Taxiway Turnpaths - Taxiway-to-Taxiway, 90 Degrees, ICAO Recommendation: Model 747-400

- NOTES:
- * SYMMETRICAL THRUST
 - * MID CG
 - * BODY GEAR STEERING INOPERATIVE
 - * NO DIFFERENTIAL BRAKING
 - * BEFORE DETERMINING THE SIZE OF INTERSECTION FILLETS, CONSULT USING AIRLINES' OR AIRPORT AUTHORITY REGARDING OPERATING PROCEDURES AND AIRCRAFT TYPES EXPECTED TO SERVE THE AIRPORT.

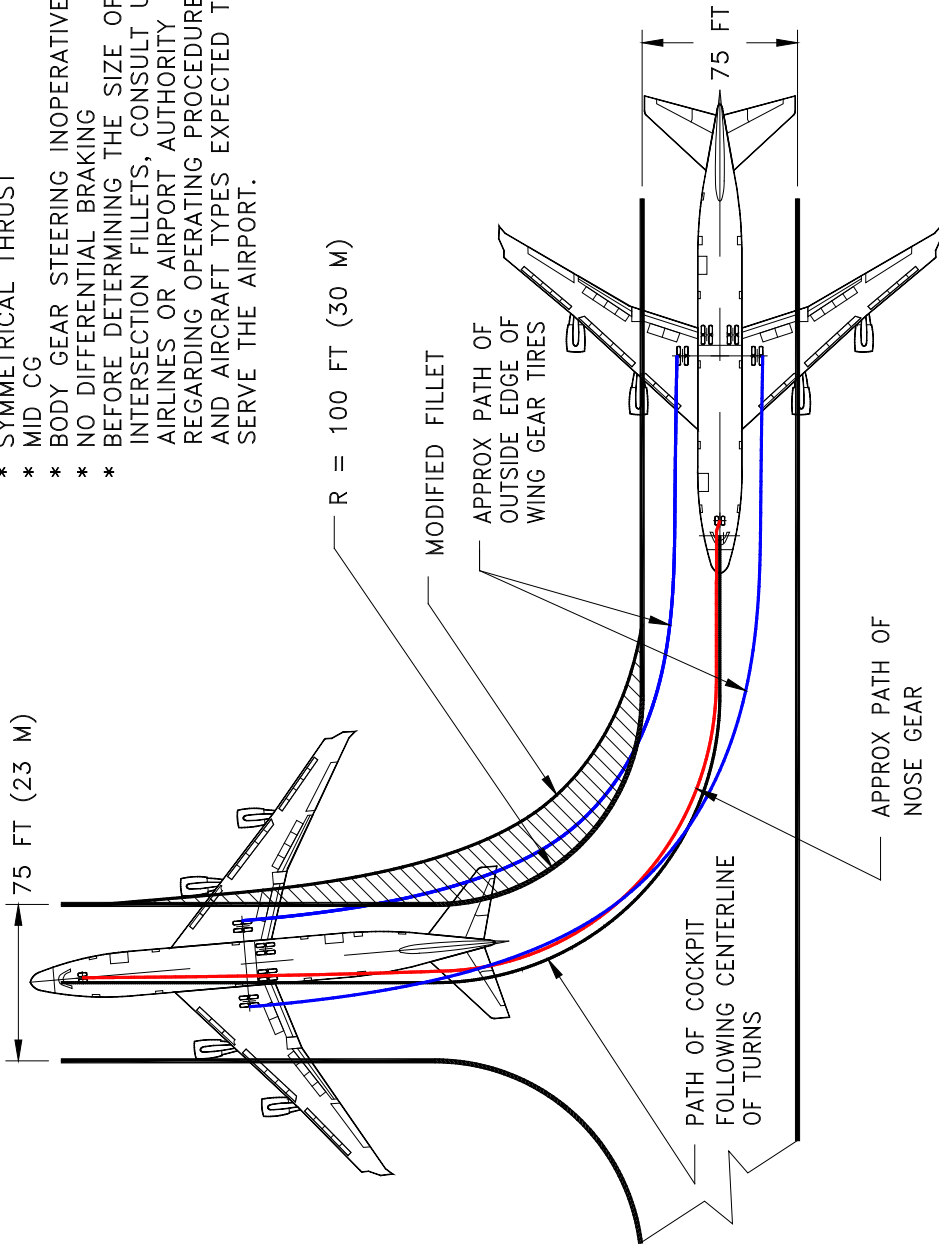

COCKPIT FOLLOWING CENTERLINE OF TURNS
(ICAO RECOMMENDATION)

4.6 RUNWAY HOLDING BAY: MODEL 747-400

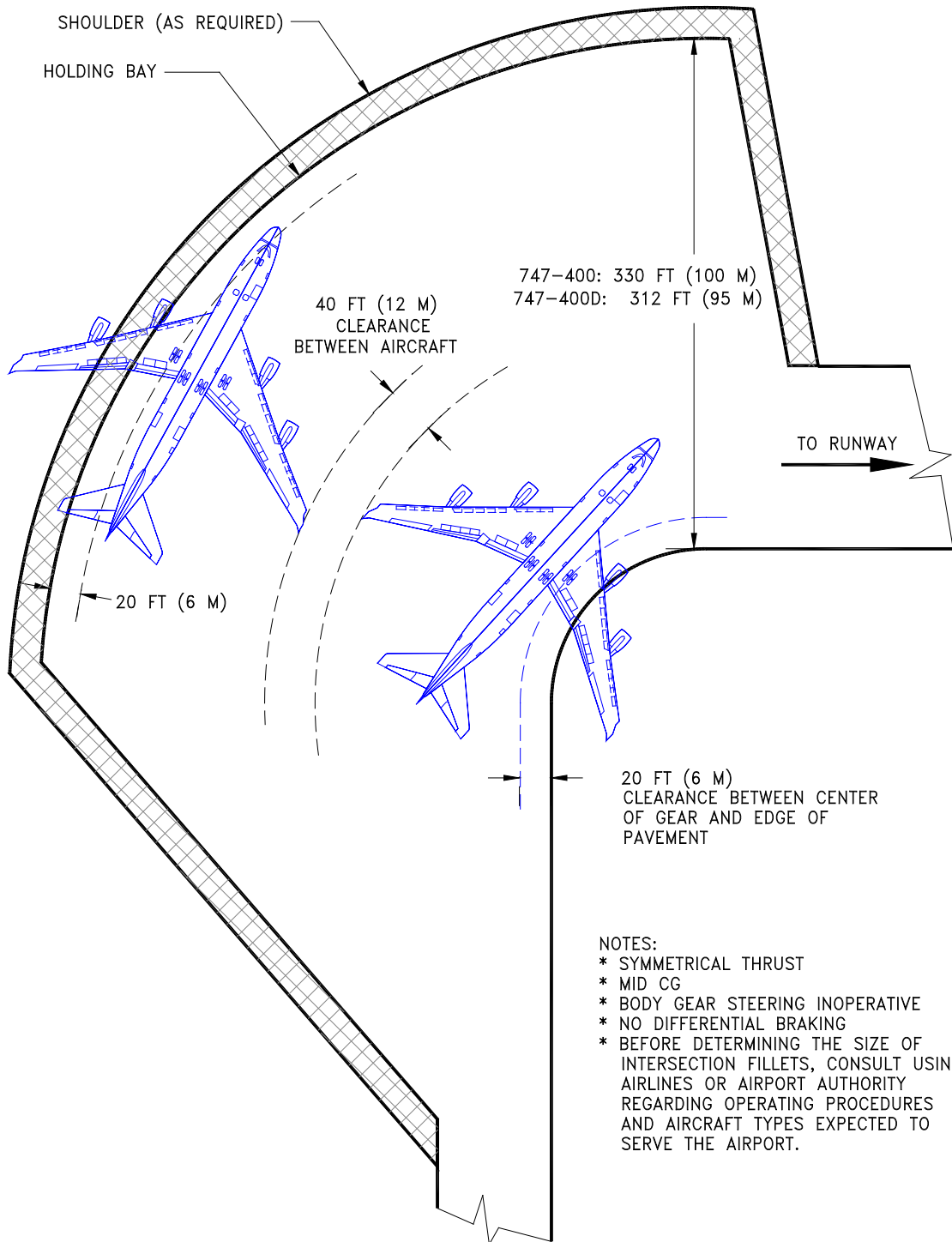

D6-58326-1

REV E

September 2023

4-19

5.0 TERMINAL SERVICING

During turnaround at the terminal, certain services must be performed on the aircraft, usually within a given time, to meet flight schedules. This section shows service vehicle arrangements, schedules, locations of service points, and typical service requirements. The data presented in this section reflect ideal conditions for a single airplane. Service requirements may vary according to airplane condition and airline procedure.

Section 5.1 shows typical arrangements of ground support equipment during turnaround. As noted, if the auxiliary power unit (APU) is used, the electrical, air start, and air-conditioning service vehicles would not be required. Passenger loading bridges or portable passenger stairs could be used to load or unload passengers.

Sections 5.2 and 5.3 show typical service times at the terminal. These charts give typical schedules for performing service on the airplane within a given time. Service times could be rearranged to suit availability of personnel, airplane configuration, and degree of service required.

Section 5.4 shows the locations of ground service connections in graphic and in tabular forms. Typical capacities and service requirements are shown in the tables. Services with requirements that vary with conditions are described in subsequent sections.

Section 5.5 shows typical sea level air pressure and flow requirements for starting different engines. The curves are based on an engine start time of 90 seconds.

Section 5.6 shows pneumatic requirements for heating and cooling (air conditioning) using high pressure air to run the air cycle machine. The curves show airflow requirements to heat or cool the airplane within a given time and ambient conditions. Maximum allowable pressure and temperature for air cycle machine operation are 60 psia and 450°F, respectively.

Section 5.7 shows pneumatic requirements for heating and cooling the airplane, using low pressure conditioned air. This conditioned air is supplied through an 8-in ground air connection (GAC) directly to the passenger cabin, bypassing the air cycle machines.

Section 5.8 shows ground towing requirements for various ground surface conditions.

5.1 AIRPLANE SERVICING ARRANGEMENT - TYPICAL TURNAROUND

5.1.1 Airplane Servicing Arrangement - Typical Turnaround: Model 747-400, -400 Domestic, -400ER

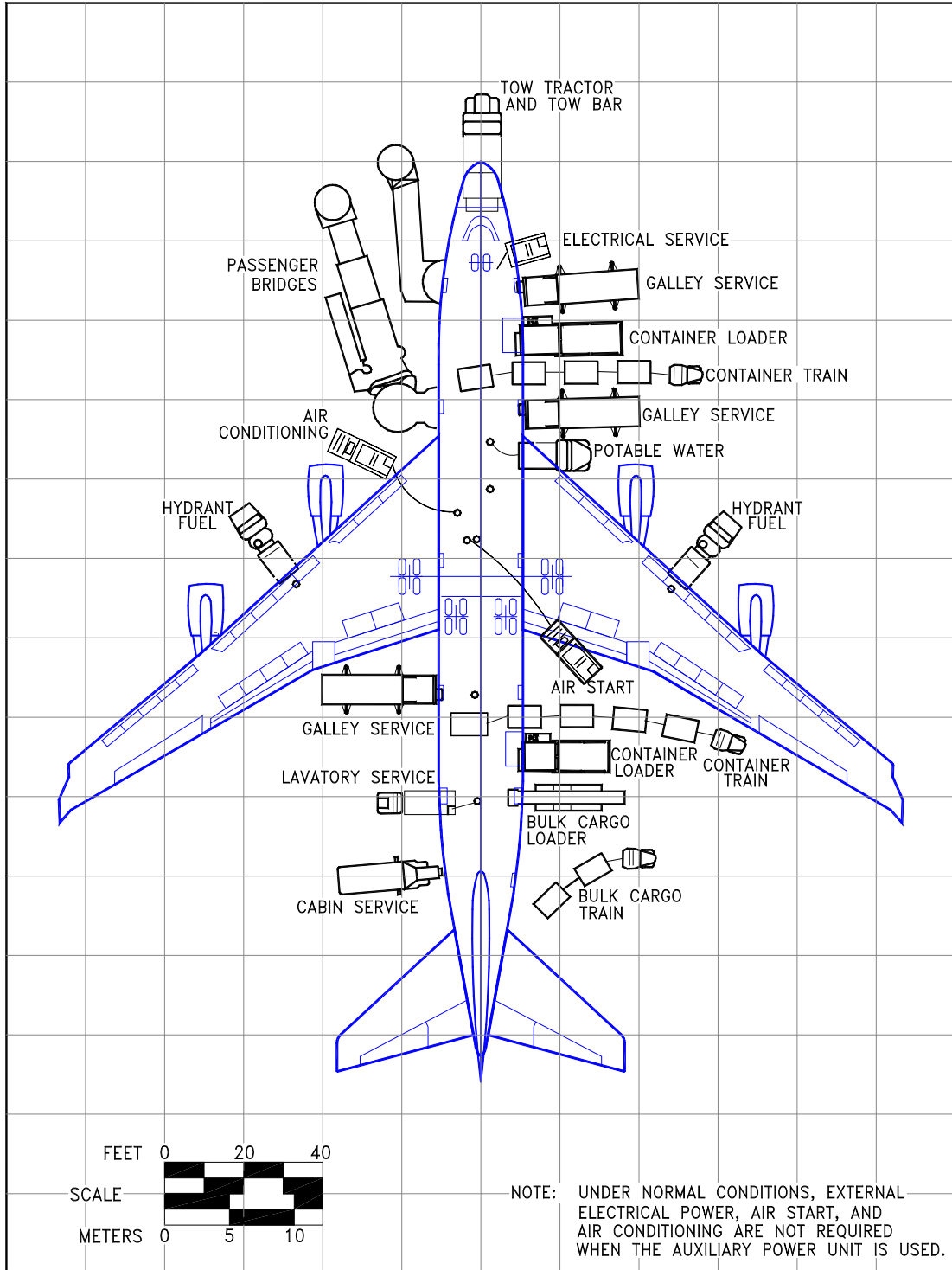

D6-58326-1

REV E

September 2023

5-2

5.1.2 Airplane Servicing Arrangement - Typical Turnaround: Model 747-400 Combi

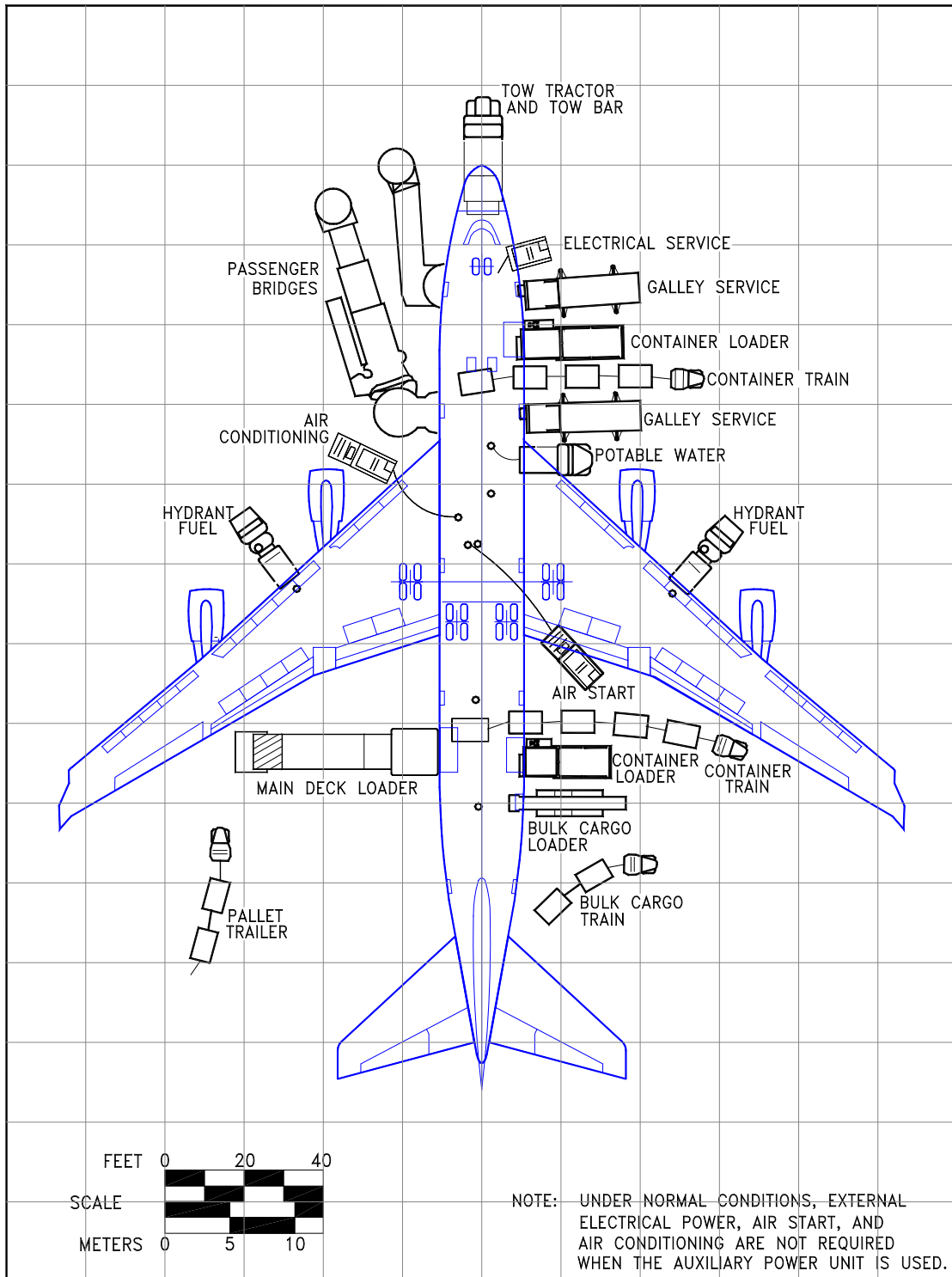

D6-58326-1

REV E

September 2023

5-3

5.1.3 Airplane Servicing Arrangement - Typical Turnaround: Model 747-400 Freighter, -400ER Freighter

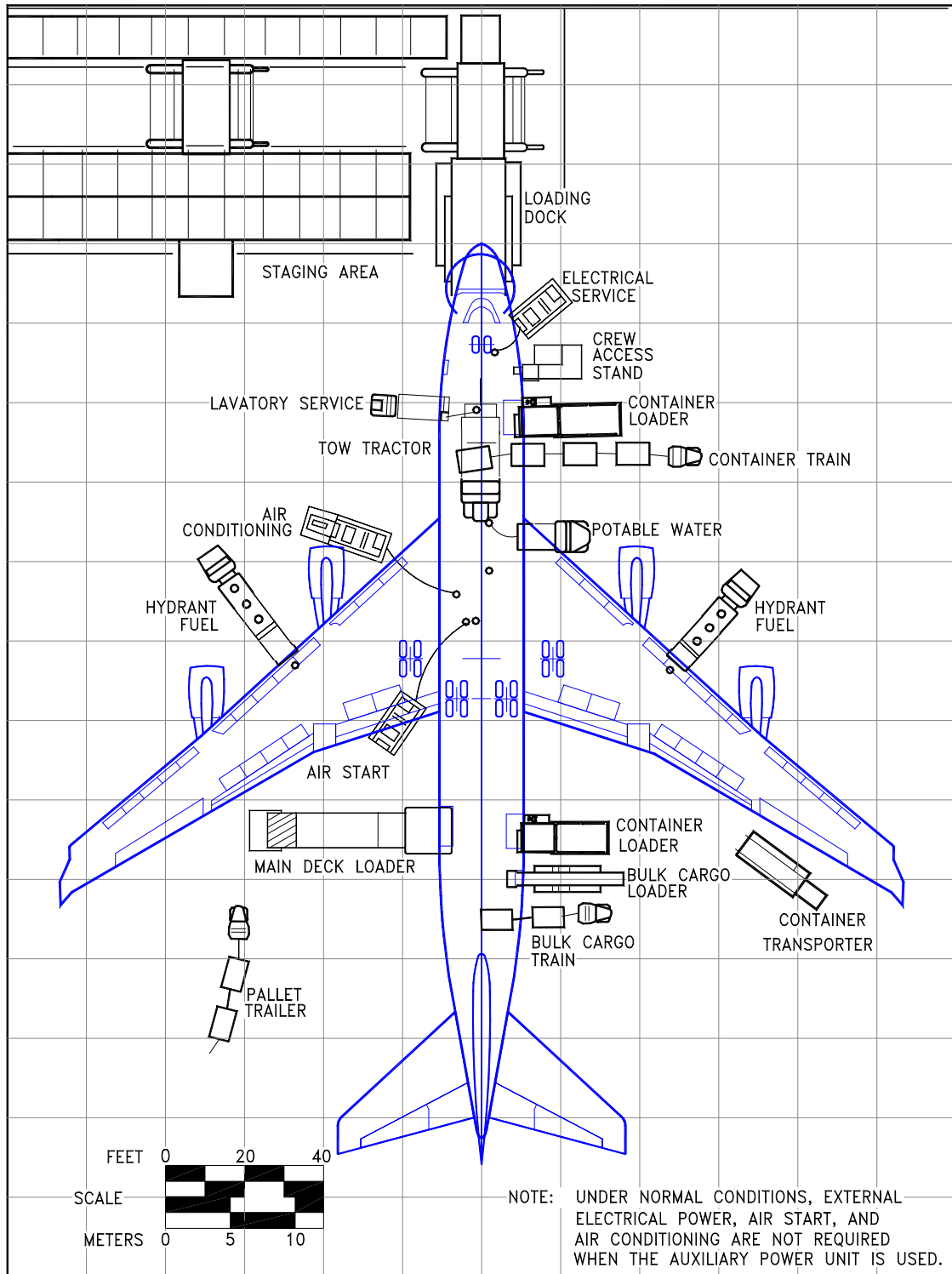

D6-58326-1

5.2 TERMINAL OPERATIONS - TURNAROUND STATION

5.2.1 Terminal Operations - Turnaround Station – All Passenger: Model 747-400, -400 Combi, -400 Domestic

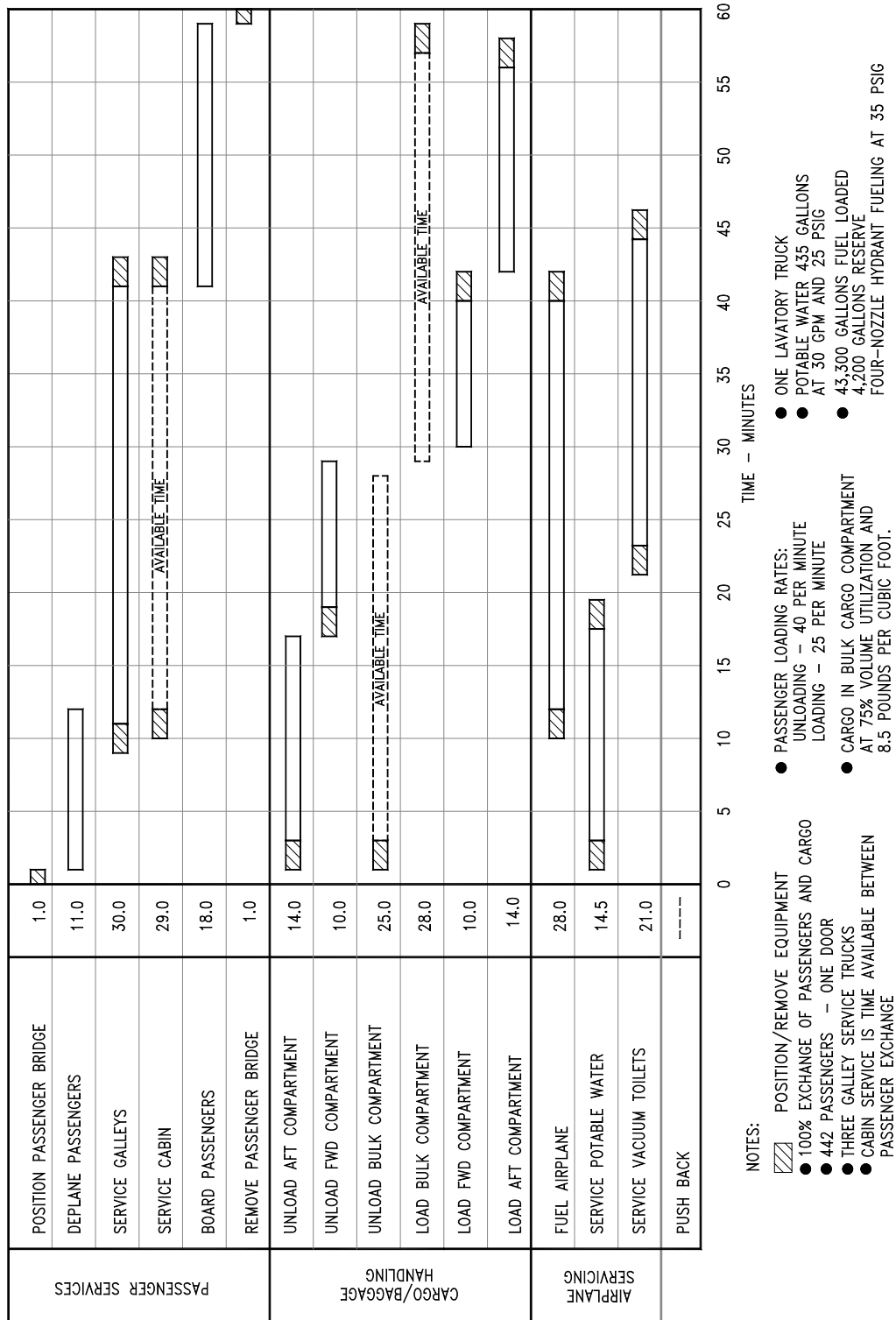

D6-58326-1

5.2.2 Terminal Operations - Turnaround Station – All Passenger: Model 747-400ER

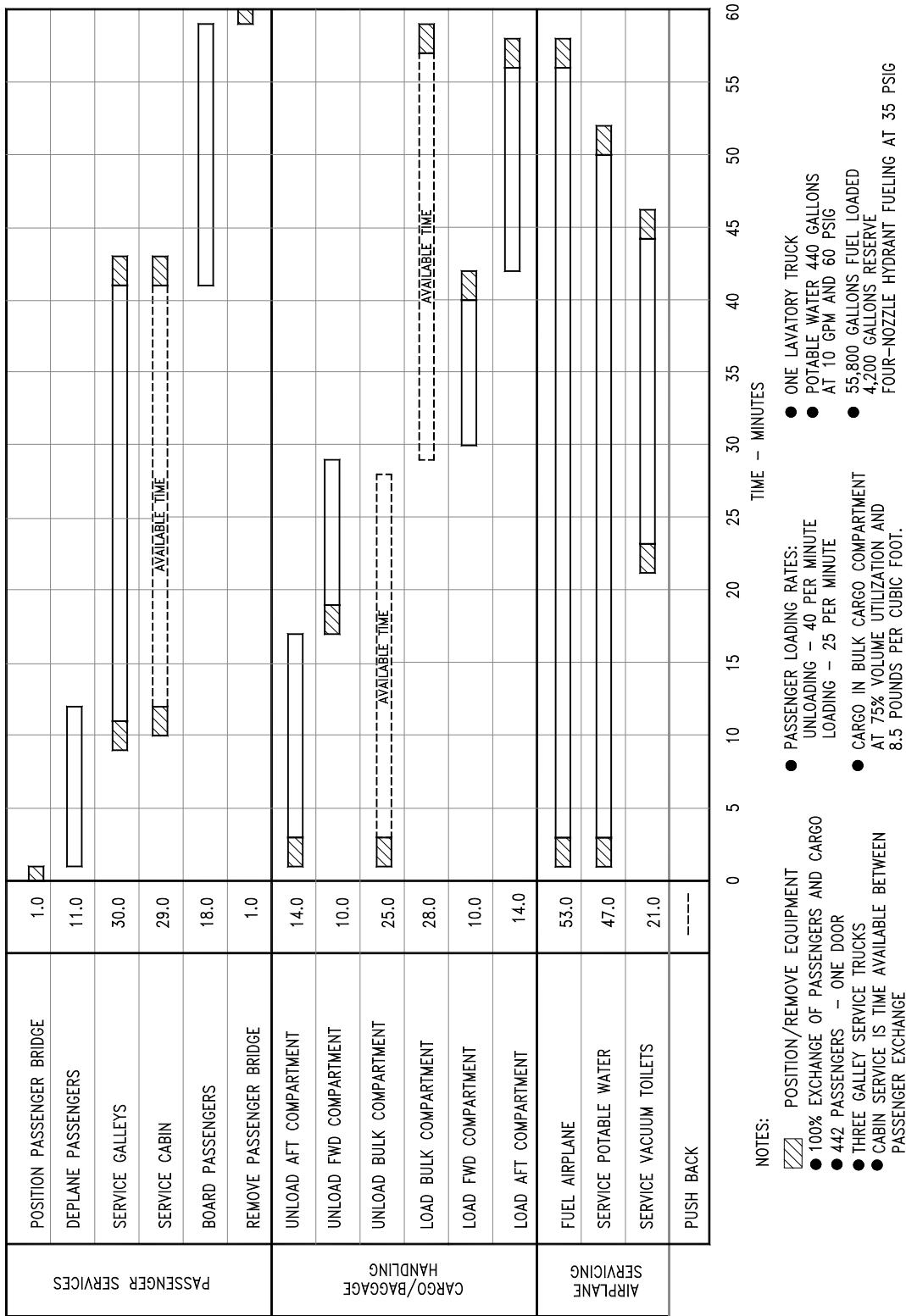

D6-58326-1

5.2.3 Terminal Operations - Turnaround Station – Passenger/Cargo: Model 747-400 Combi

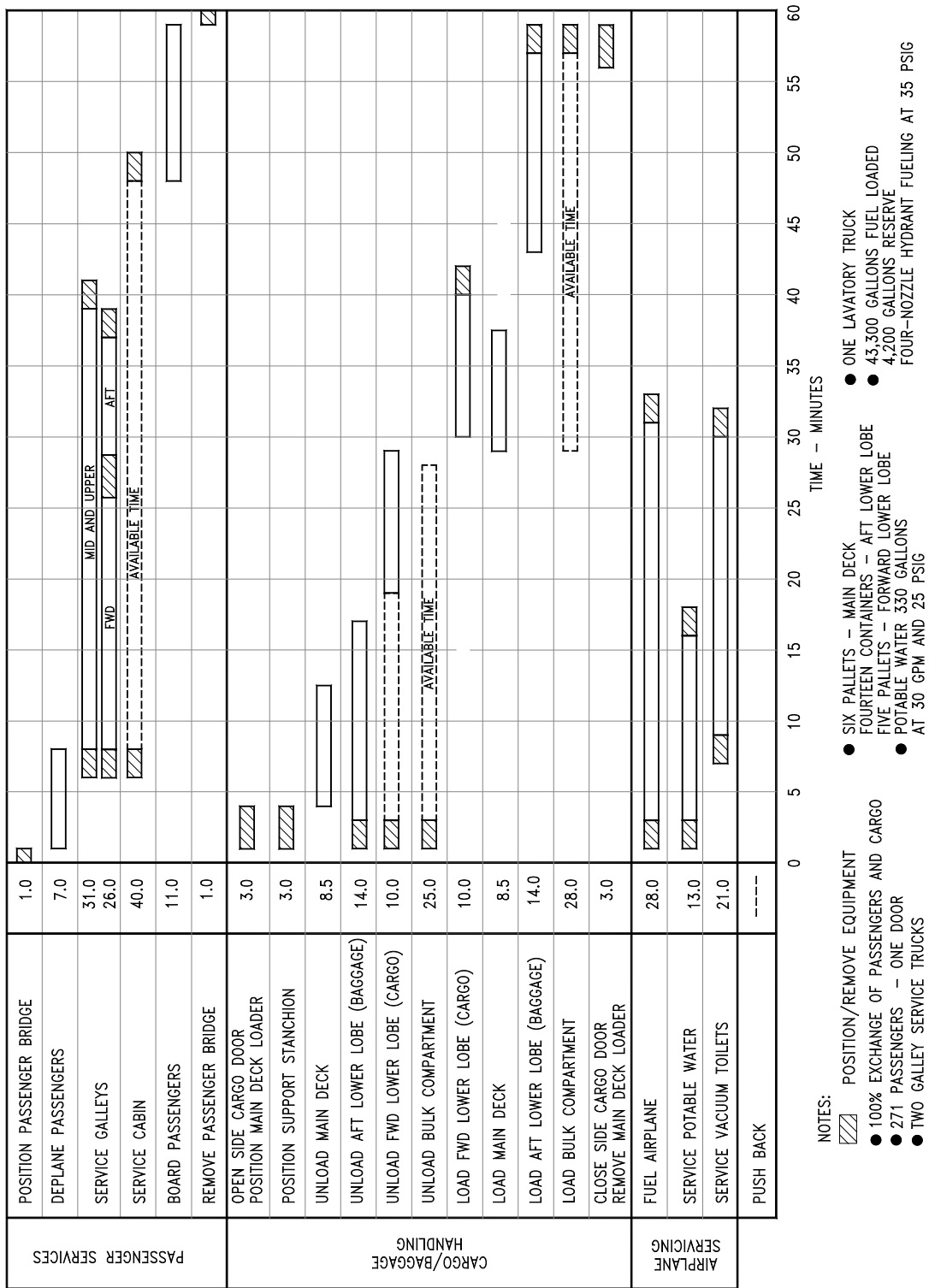

5.2.4 Terminal Operations – Turnaround Station – All Cargo, Nose Door Loading: Model 747-400 Freighter, -400ER Freighter

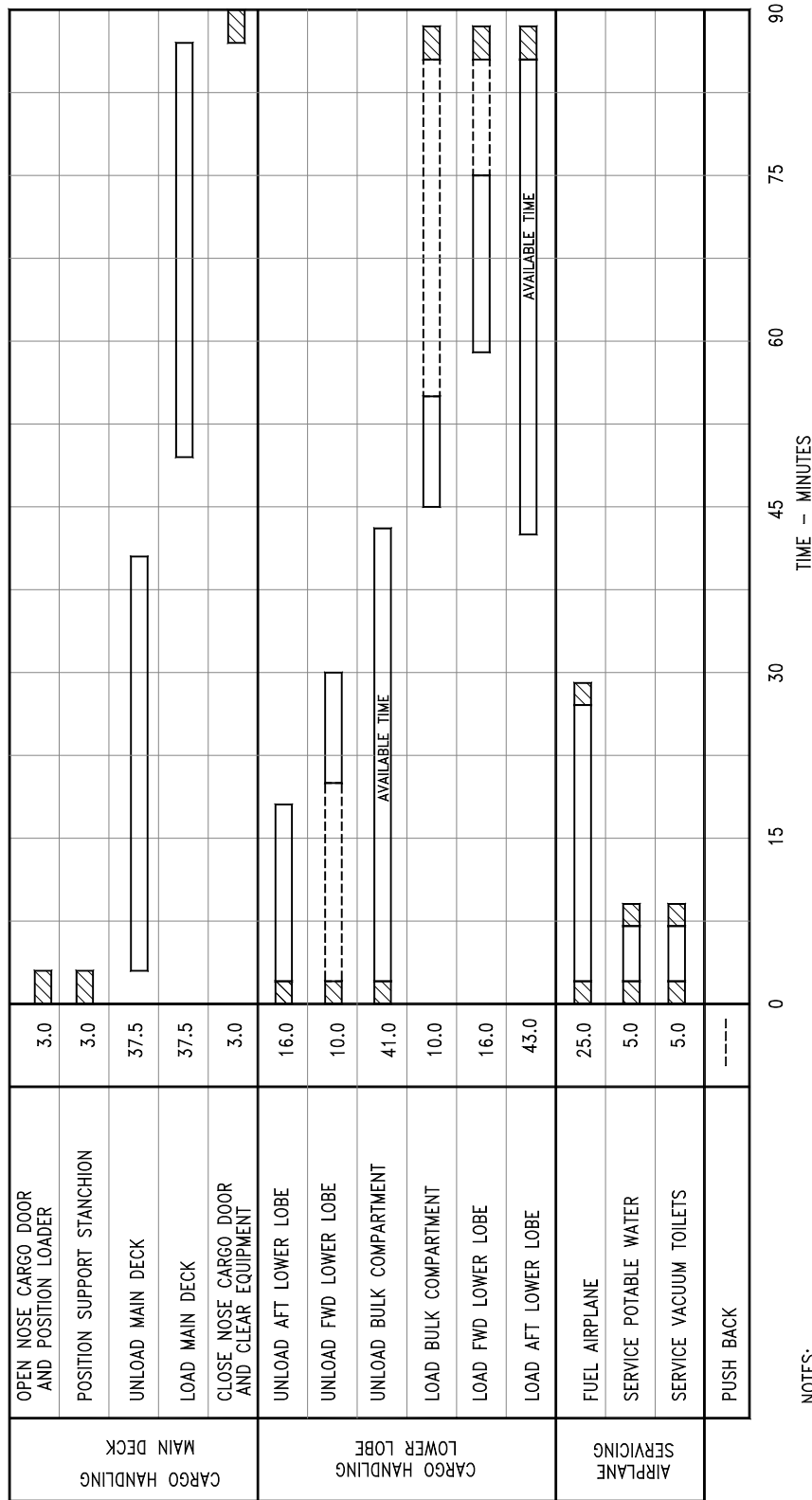

- NOTES:
- ▨ POSITION/REMOVE EQUIPMENT
 - MAIN DECK CARGO – (30) 96 x 125-IN ULD'S
 - 100% CARGO EXCHANGE
 - 16 CONTAINERS – AFT LOWER LOBE
 - 5 PALLETS – FWD LOWER LOBE
 - 40,000 GALLONS FUEL LOADED
 - 4,200 GALLONS RESERVE
 - 4-NOZZLE HYDRANT FUELING AT 35 PSIG
 - ONE TOILET TRUCK – FORWARD TOILET
 - POTABLE WATER – 30 GALLONS

5.2.6 Terminal Operations – Turnaround Station – All Cargo, Nose and Side Cargo Door Loading: Model 747-400 Freighter, -400ER Freighter

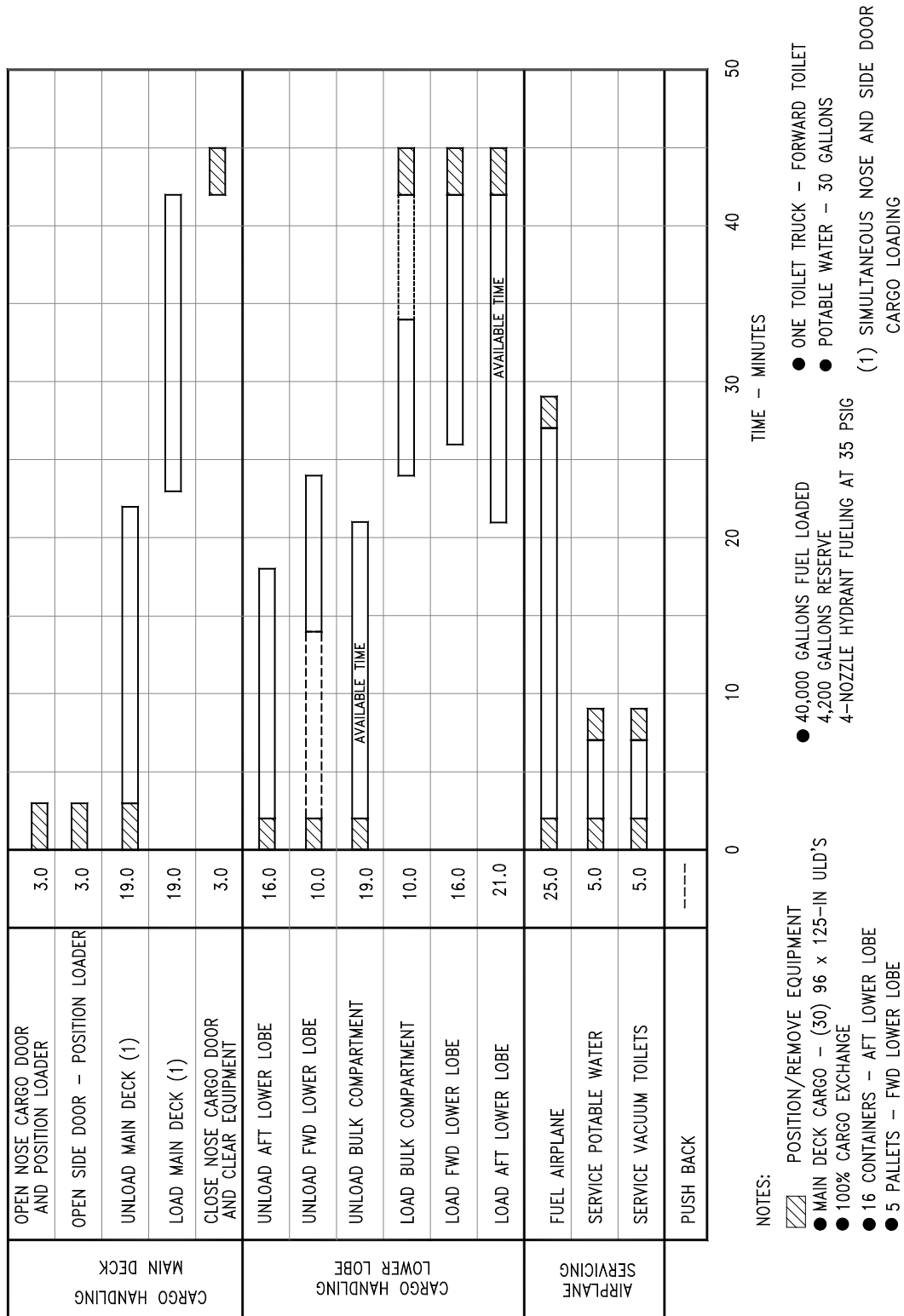

D6-58326-1

5.3 TERMINAL OPERATIONS - EN ROUTE STATION

5.3.1 Terminal Operations - En Route Station - All Passenger: Model 747-400, -400 Combi, -400 Domestic

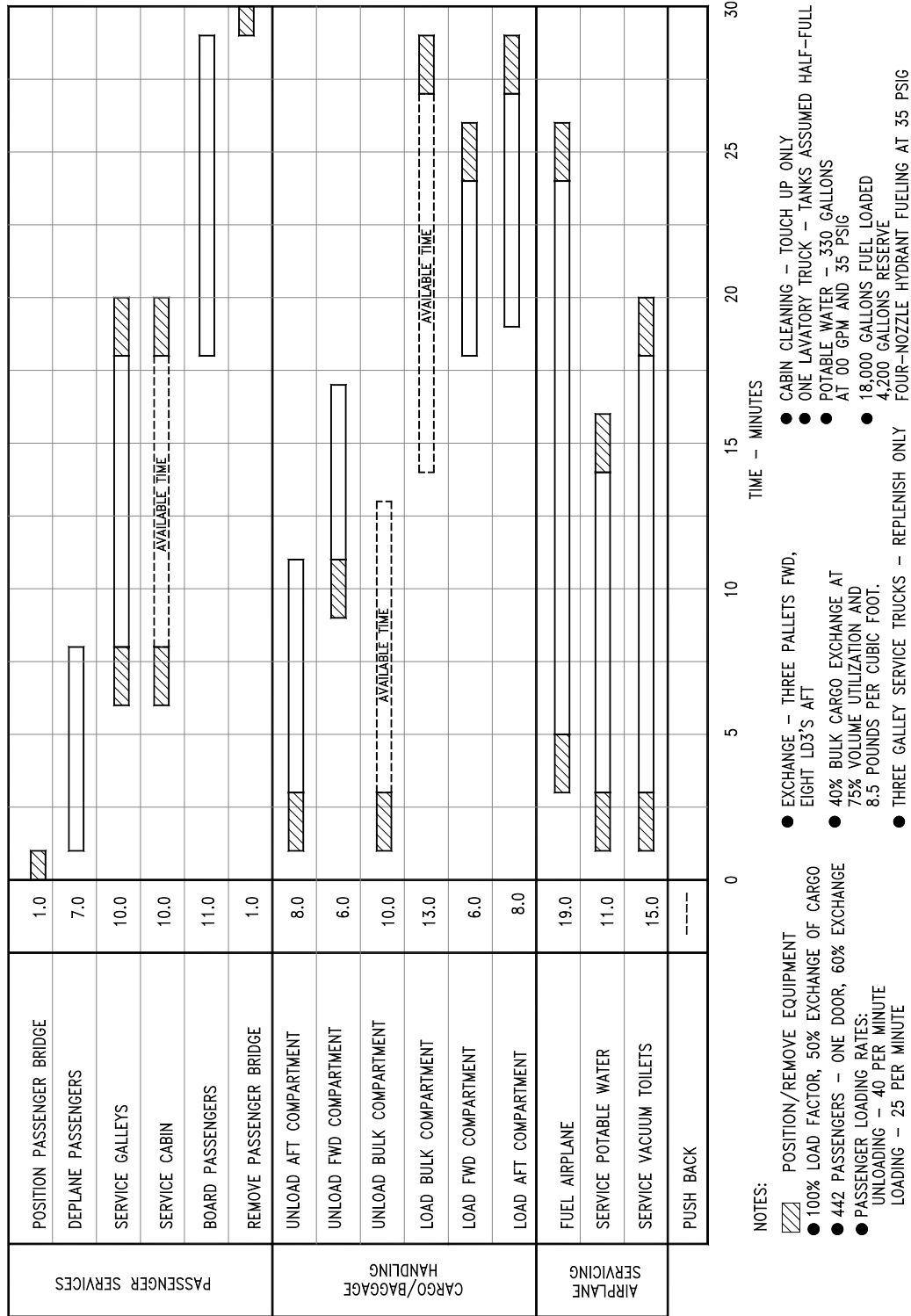

5.4 GROUND SERVICING CONNECTIONS

5.4.1 Ground Service Connections: Model 747-400

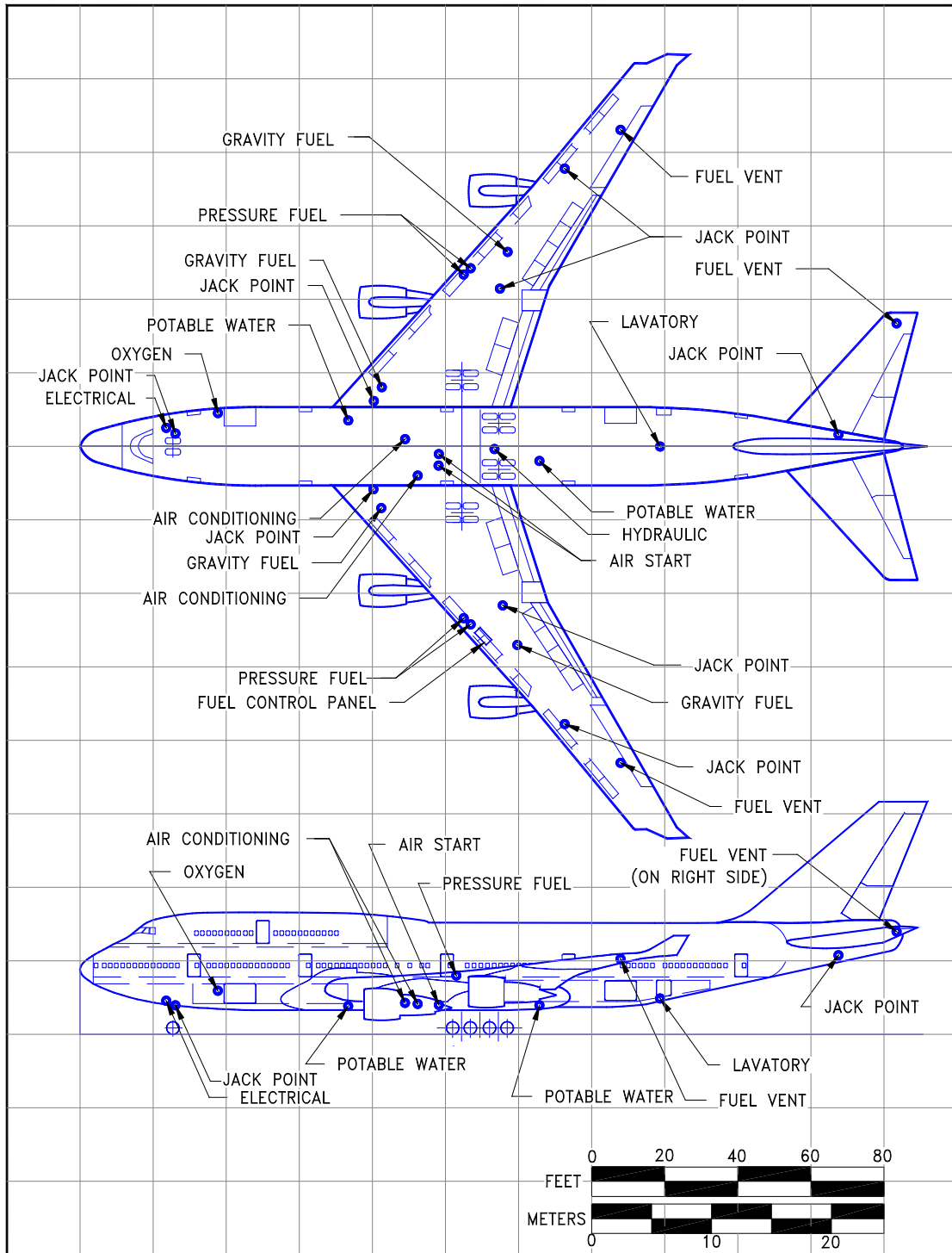

D6-58326-1

5.4.2 Ground Service Connections: Model 747-400

SYSTEM	DISTANCE AFT OF		DISTANCE FROM AIRPLANE CENTERLINE				HEIGHT ABOVE GROUND			
	NOSE		LH SIDE		RH SIDE		MINIMUM		MAXIMUM	
	FT-IN	M	FT-IN	M	FT-IN	M	FT-IN	M	FT-IN	M
ELECTRICAL TWO CO-LOCATED CONNECTORS - 90 KVA, 200/115 V AC 400 HZ, 3-PHASE EA.	26 - 9	8.15	-	-	3 - 4	1.02	7 - 10	2.39	9 - 4	2.85
FUEL FOUR UNDER-WING PRESSURE CONNECTORS (2 ON EACH WING) MAX FUELING RATE 500 US GPM (1,890 LPM) PER NOZZLE OR 2000 US GPM (7570 LPM) TOTAL MAX FUEL PRESSURE 50 PSIG (3.52 KG/CM ²) OVERWING GRAVITY FUEL CONNECTIONS FUELING CONTROL PANEL	104 - 7 105 - 7	31.89 32.18	45 - 8 46 - 9	13.91 14.26	45 - 8 46 - 9	13.91 14.26	14 - 9 14 - 9	4.50 4.50	15 - 10 15 - 10	4.84 4.84
WING FUEL VENT	146 - 9	44.73	89 - 4	27.23	89 - 4	27.23	16 - 10	5.12	19 - 3	5.86
TAIL FUEL VENT	221 - 3	67.44	-	-	29 - 10	9.09	27 - 1	8.24	28 - 9	8.75
TANK CAPACITIES:	SEE BELOW TABLE FOR TANK CAPACITIES									

FUEL TANK	VOLUME	RB211-524G, RB211-524H PW 4058, PW 4062	CF6-80C2B1 CF6-80C2B5
RESERVE NO 2 & 3	U.S. GALLONS	1,298 EACH	1,322 EACH
	LITERS	4,913 EACH	5,004 EACH
MAIN NO 1 & 2	U.S. GALLONS	4,506 EACH	4,372 EACH
	LITERS	17,055 EACH	16,548 EACH
MAIN NO 2 & 3	U.S. GALLONS	12,546 EACH	12,546 EACH
	LITERS	47,486 EACH	47,486 EACH
CENTER WING	U.S. GALLONS	17,164	17,164
	LITERS	64,960	64,960
HORIZONTAL STABILIZER	U.S. GALLONS	3,300	3,300
	LITERS	12,490	12,490
BODY FUEL TANKS (747-400ER ONLY)	U.S. GALLONS	3,060 EACH	3,060 EACH
	LITERS	11,582 EACH	11,582 EACH
MANIFOLD, LINES, & MISC	U.S. GALLONS	121 (-400), 176 (-400ER)	121 (-400), 176 (-400ER)
	LITERS	458 (-400), 666 (-400ER)	458 (-400), 666 (-400ER)
TOTAL USABLE (747-400 ONLY)	U.S. GALLONS	57,340	57,120
	LITERS	217,032	216,199
TOTAL USABLE (747-400ER ONLY)	U.S. GALLONS	63,460	63,240
	LITERS	240,196	239,363

D6-58326-1

5.4.3 Ground Servicing Connections: Model 747-400

SYSTEM	DISTANCE AFT OF		DISTANCE FROM AIRPLANE CENTERLINE				HEIGHT ABOVE GROUND			
	NOSE		LH SIDE		RH SIDE		MINIMUM		MAXIMUM	
	FT-IN	M	FT-IN	M	FT-IN	M	FT-IN	M	FT-IN	M
LAVATORY ONE SERVICE PANEL: THREE SERVICE CONNECTIONS DRAIN: ONE 4-IN (10.2 CM) FLUSH: TWO 1-IN (2.5 CM) FLUSH REQS: FLOW: 10 GPM (38 LPM), 30 PSIG (2.11 KG/CM ²) TOTAL CAPACITY, 4 TANKS 300 US GAL (1,140 L)	160 - 0	48.77	0	0	0	0	8 - 9	2.67	9 - 11	3.03
PNEUMATIC TWO 3-IN (7.6 CM) HIGH-PRESSURE PORTS	96 - 6	29.42	2 - 0	0.61	-	-	6 - 7	2.01	7 - 5	2.27
	96 - 6	29.42	3 - 0	0.91	-	-	6 - 7	2.01	7 - 5	2.27
TWO 8-IN (.20 M) GROUND CONDITIONED AIR CONNECTIONS	89 - 0	27.13	-	-	1 - 10	0.55	7 - 4	2.24	8 - 3	2.52
	93 - 4	28.45	7 - 11	2.40	-	-	7 - 0	2.13	7 - 11	2.40
TANK CAPACITIES: POTABLE WATER - ONE CONNECTION, SIZE 3/4 IN (1.95 CM), CAPACITY - 330 U.S GAL (1,250 L), MAX FILL PRESSURE - 30 PSIG (2.11 KG/SQ CM), FILL RATE - 30 GPM (113.5 LPM) DRAIN SIZE 1 IN (2.54 CM) SECOND CONNECTION (ON 747-400ER ONLY)	127 - 2	38.76	2 - 10	0.87	-	-	7 - 3	2.20	8 - 2	2.48
HYDRAULIC ONE SERVICE PANEL 4 RESERVOIRS ENG 1 - 9.5 U.S. GAL (35.9 L) ENG 2 - 5.5 U.S. GAL (20.8 L) ENG 3 - 5.5 U.S. GAL (20.8 L) ENG 4 - 9.5 U.S. GAL (35.9 L) 150 PSI (10.6 KG/CM ²) MAX	114 - 0	34.75	0 - 10	0.25	-	-	7 - 0	2.13	7 - 0	2.13
OXYGEN ONE SERVICE CONNECTION - SIZE 3/16 IN (0.48 CM) 1850 PSIG (130 KG/CM ²) MAX	39 - 2	11.94	-	-	8 - 5	2.55	13 - 5	4.09	14 - 10	4.51

D6-58326-1

5.5 ENGINE STARTING PNEUMATIC REQUIREMENTS

5.5.1 Engine Start Pneumatic Requirements - Sea Level: Model 747-400 (CF6-80C2B1 Engines, Garrett Starter)

- NOTES:
- ALTITUDE – SEA LEVEL
 - GARRETT STARTER MODEL ATS100-350L
 - USE OF TWO GROUND CONNECTIONS IS ASSUMED
 - PROVIDES MINIMUM ENGINE STARTING REQUIREMENTS

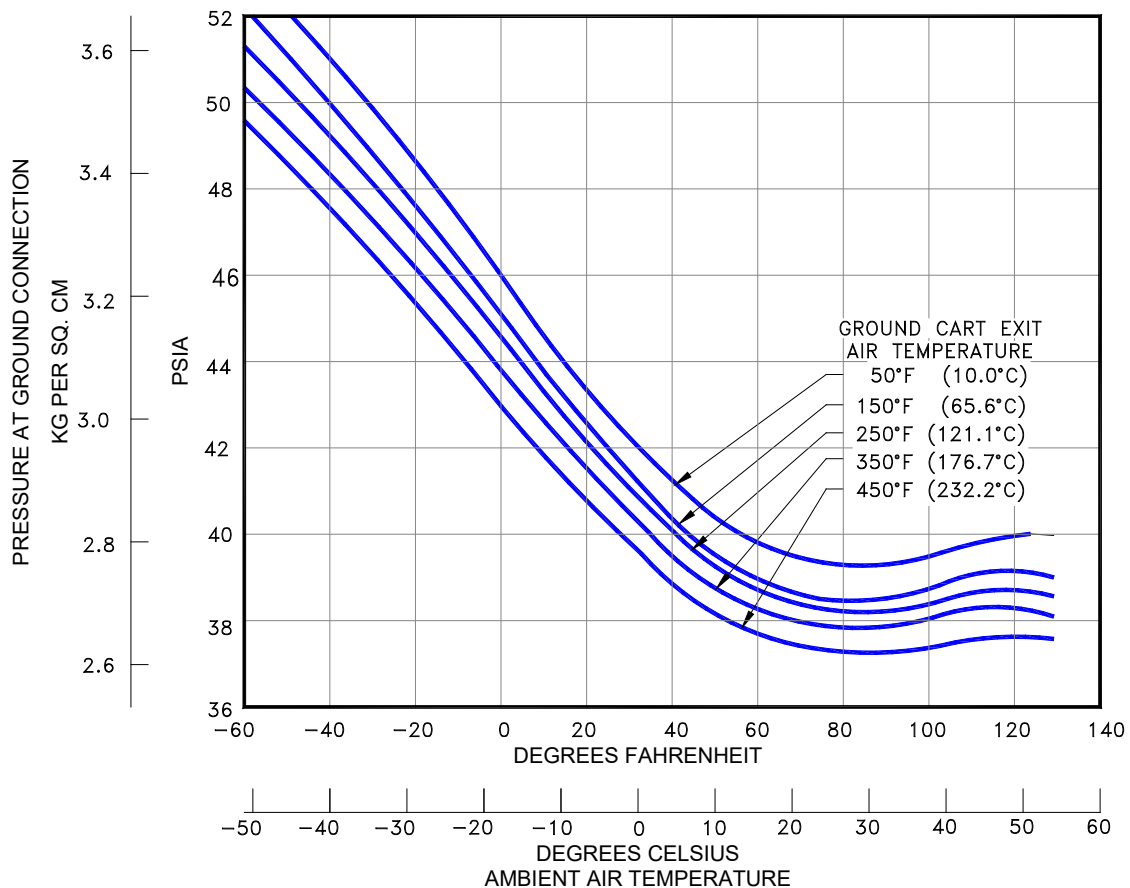
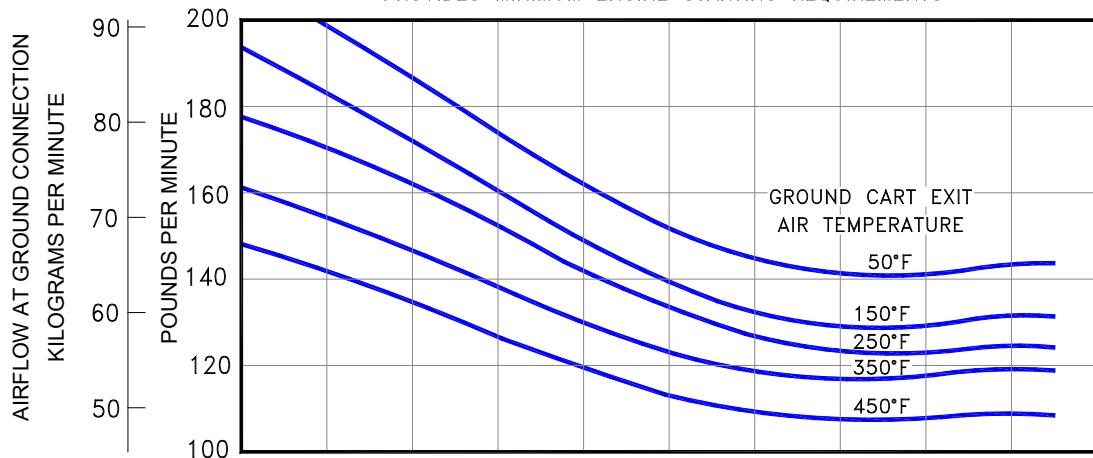

D6-58326-1

5.5.2 Engine Start Pneumatic Requirements - Sea Level: Model 747-400 (CF6-80C2B1 Engines, Hamilton Standard Starter)

- NOTES:
- ALTITUDE – SEA LEVEL
 - HAMILTON STANDARD STARTER MODEL PS600–6
 - USE OF TWO GROUND CONNECTIONS IS ASSUMED
 - PROVIDES MINIMUM ENGINE STARTING REQUIREMENTS

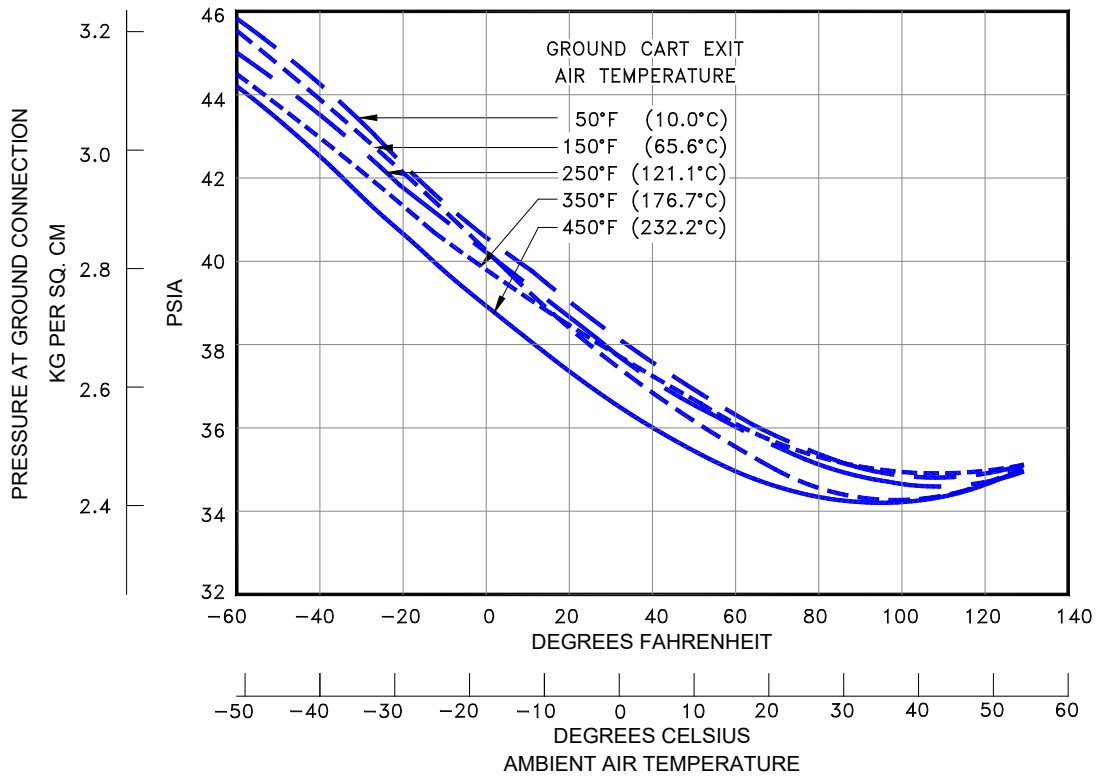
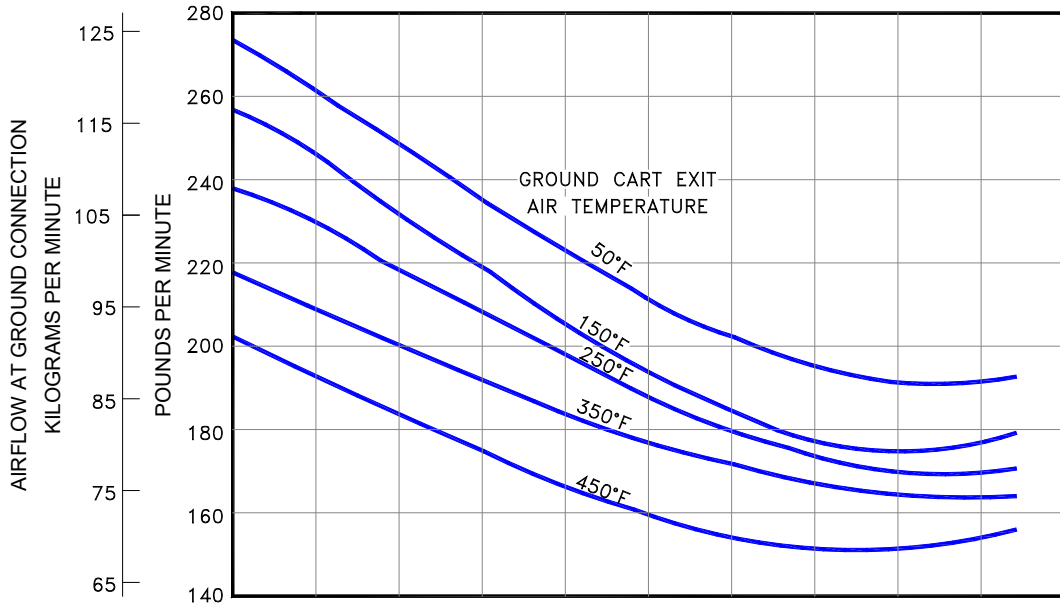

D6-58326-1

5.5.3 Engine Start Pneumatic Requirements - Sea Level: Model 747-400 (PW 4056 Engines, Garrett Starter)

- NOTES:
- ALTITUDE – SEA LEVEL
 - GARRETT STARTER MODEL ATS200–58
 - USE OF TWO GROUND CONNECTIONS IS ASSUMED
 - PROVIDES MINIMUM ENGINE STARTING REQUIREMENTS

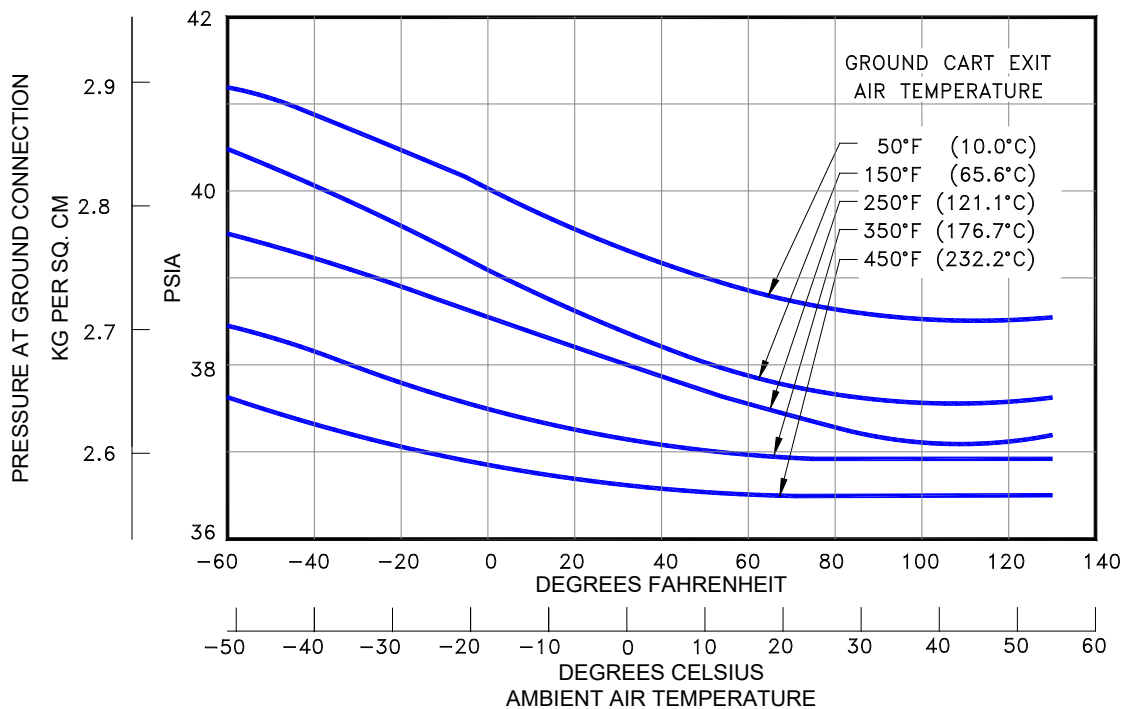
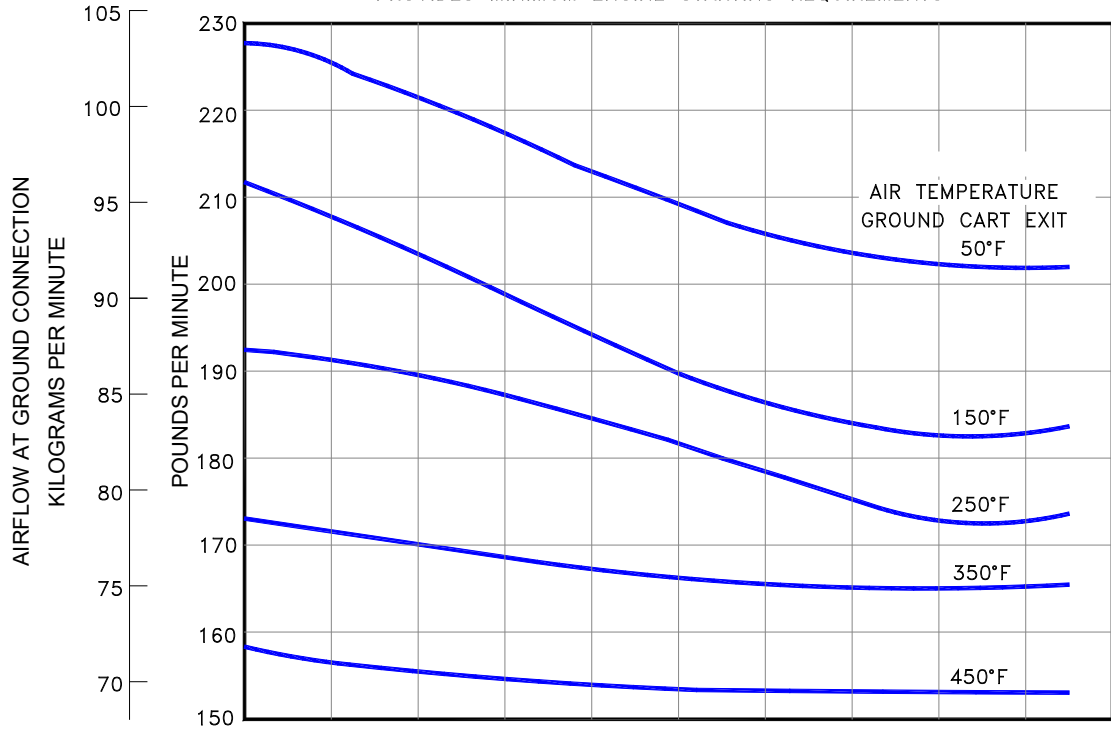

D6-58326-1

5.5.4 Engine Start Pneumatic Requirements - Sea Level: Model 747-400 (PW 4056 Engines, Hamilton Standard Starter)

NOTES:

- ALTITUDE – SEA LEVEL
- HAMILTON STANDARD STARTER MODEL PS700-5
- USE OF TWO GROUND CONNECTIONS IS ASSUMED
- PROVIDES MINIMUM ENGINE STARTING REQUIREMENTS

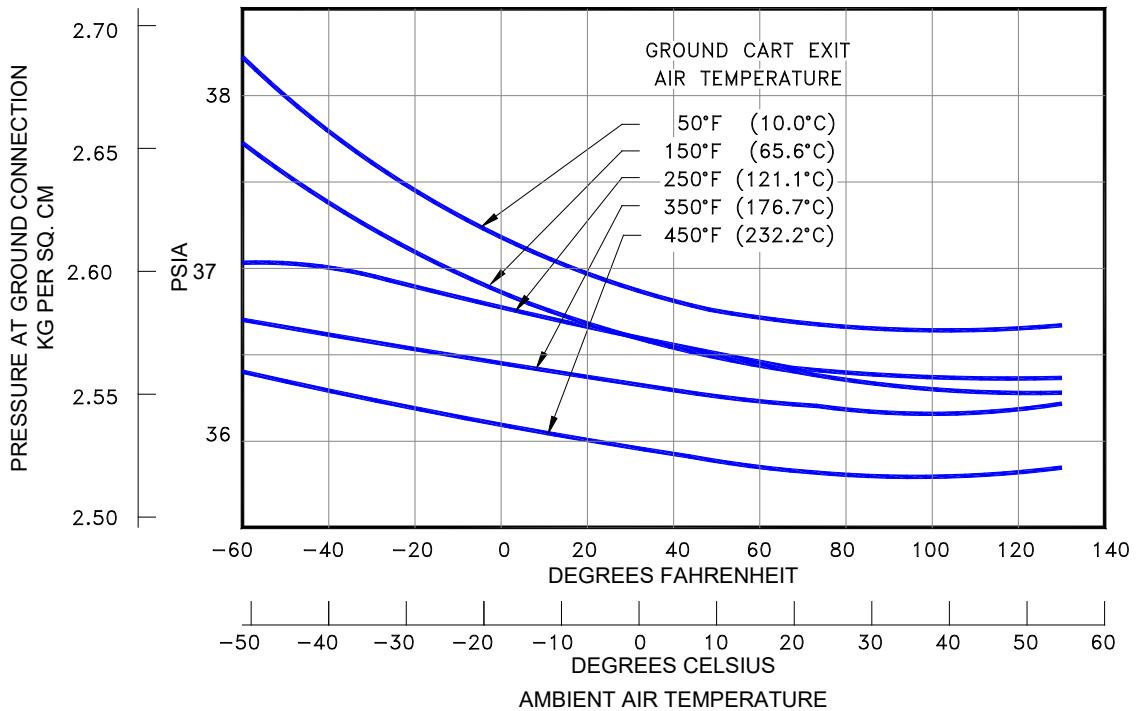
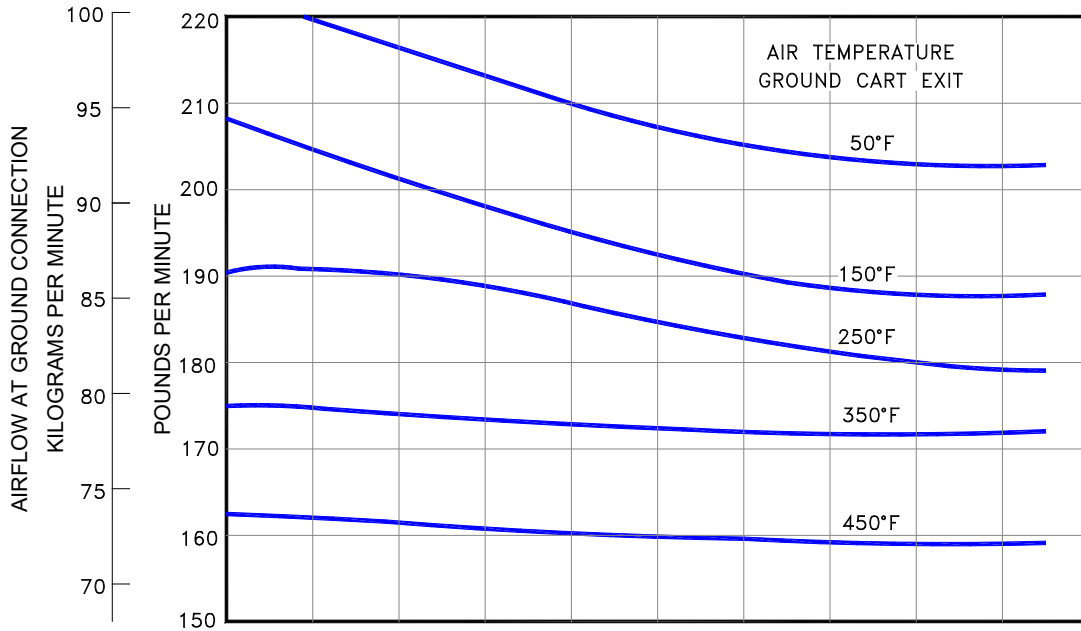

5.5.5 Engine Start Pneumatic Requirements - Sea Level: Model 747-400 (RB211-524G Engines)

NOTES:

- ALTITUDE – SEA LEVEL
- HAMILTON STANDARD STARTER MODEL PS600-3
- USE OF TWO GROUND CONNECTIONS IS ASSUMED
- PROVIDES MINIMUM ENGINE STARTING REQUIREMENTS

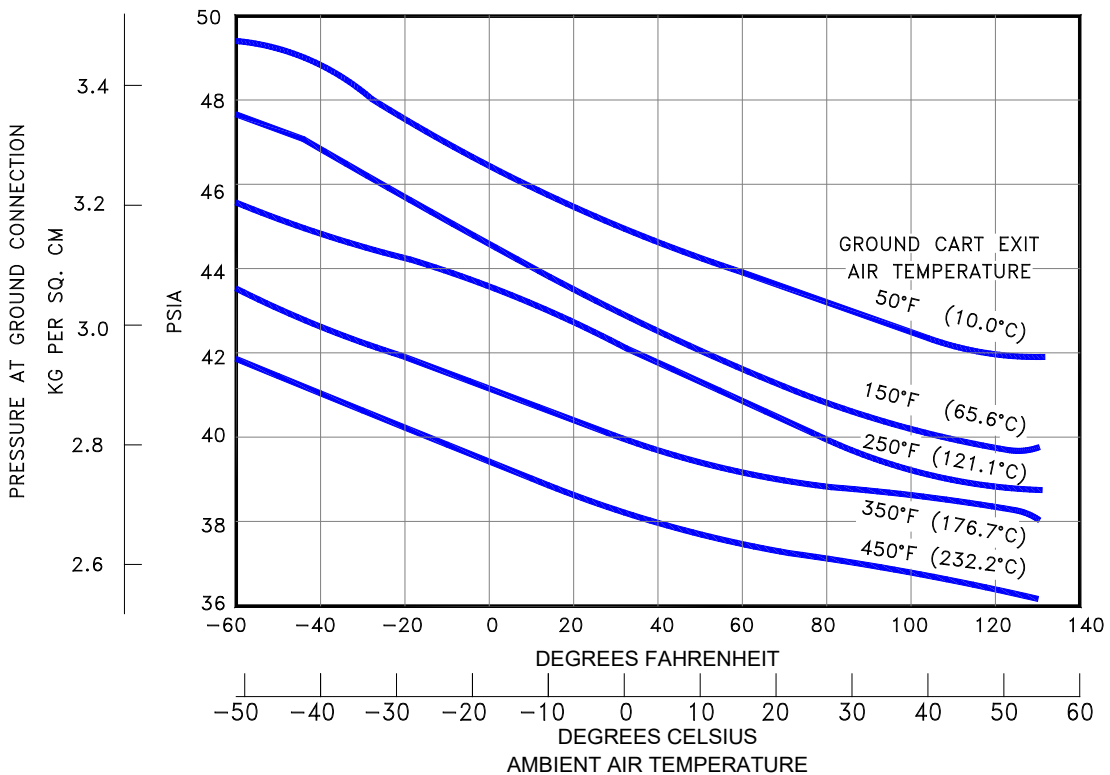
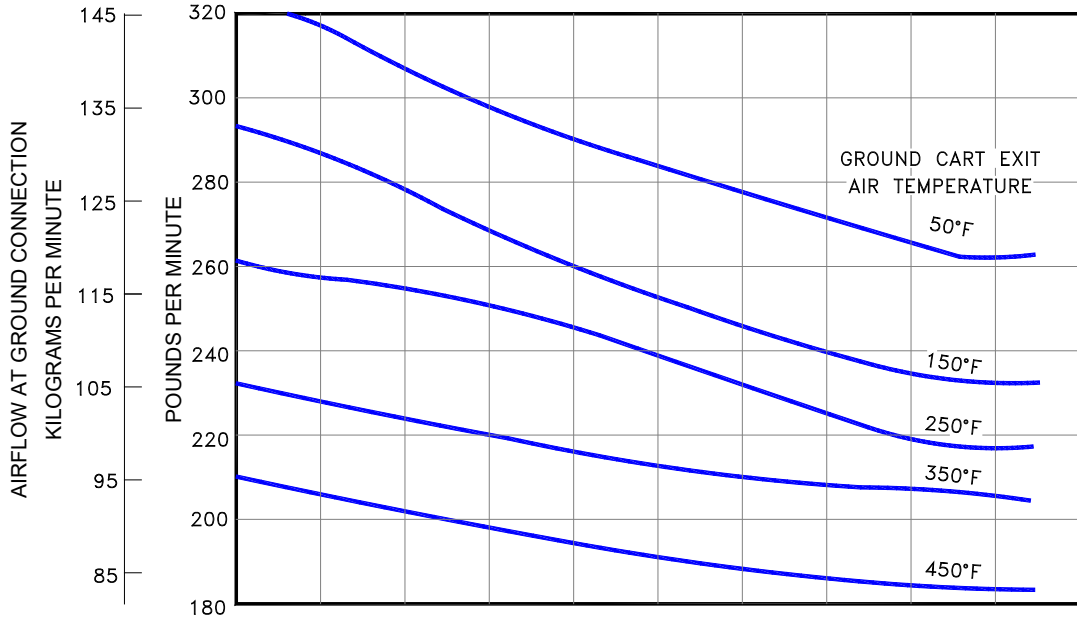

D6-58326-1

5.6 GROUND PNEUMATIC POWER REQUIREMENTS

5.6.1 Ground Pneumatic Power Requirements - Heating/Cooling: Model 747-400

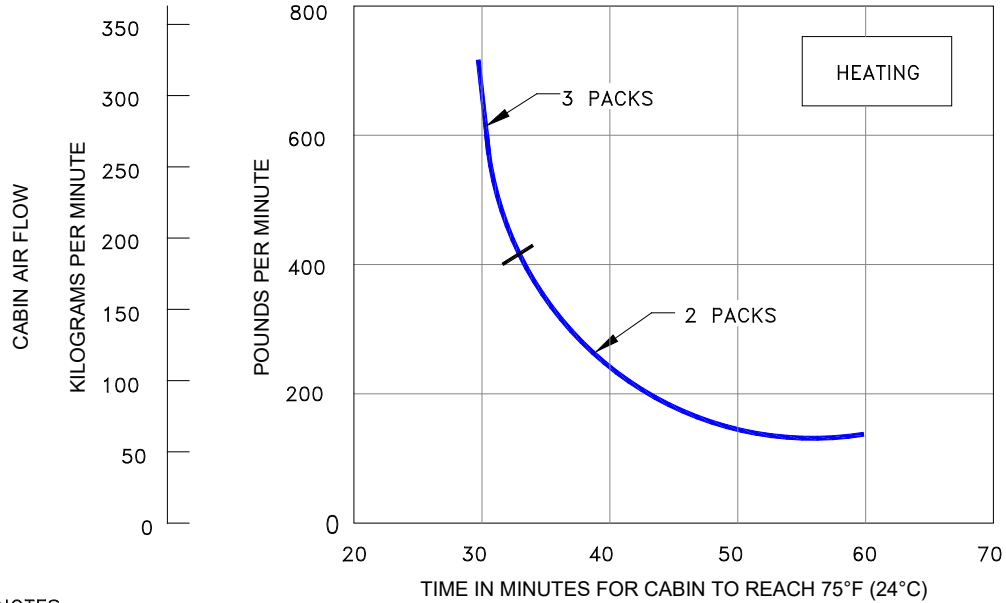

NOTES:

- AMBIENT AND INITIAL CABIN TEMP. -25°F (-32°C)
- PACK OUTLET TEMP. 160°F (71°C)
- RECIRCULATING FANS OFF
- NO PASSENGERS
- DOORS CLOSED
- NO GALLEY LOAD
- NO LIGHTING LOAD

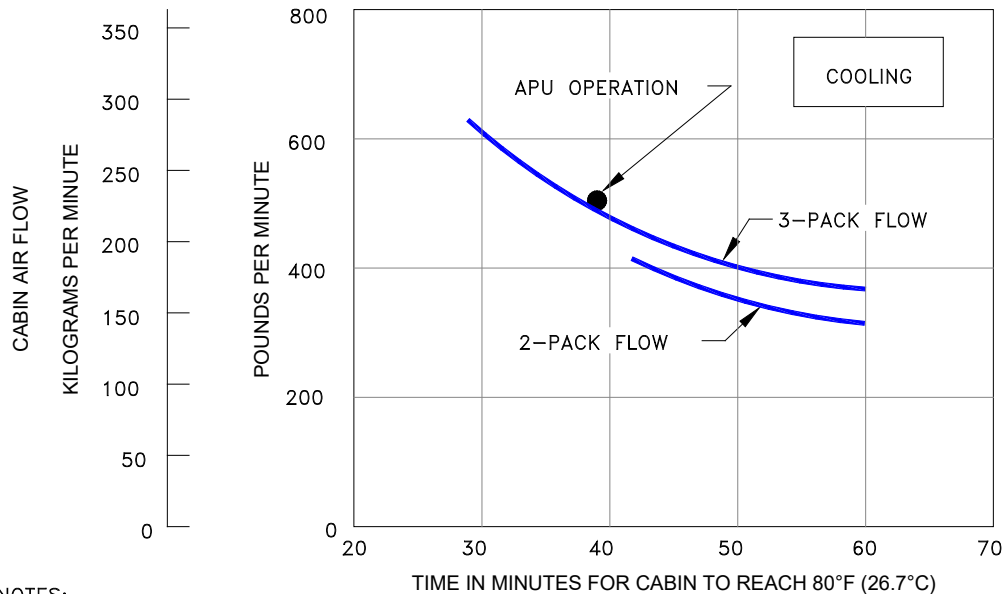

NOTES:

- INITIAL CABIN TEMP. AT 115°F (46.1°C)
- OUTSIDE AIR TEMP. AT 100°F (37.8°C)
- TEMP. AT GROUND CONNECTION 400°F (204.4°C)
- NO PASSENGERS
- DOORS CLOSED
- NO GALLEY LOAD
- NO LIGHTING LOAD

D6-58326-1

5.7 CONDITIONED AIR REQUIREMENTS

5.7.1 Conditioned Air Flow Requirements: Model 747-400

CONDITIONS:

ALL DOORS AND HATCHES CLOSED

- ① 75°F (23.9°C) CABIN TEMP. 590 OCCUPANTS: 28,000 BTU/HR (7,050 KCAL/HR) SOLAR LOAD AND 75,000 BTU/HR (18,900 KCAL/HR) ELECTRICAL LOAD
- ② 80°F (26.7°C) CABIN TEMP. HEAT LOADS SAME AS ①, ABOVE
- ③ 75°F (23.9°C) CABIN TEMP. 3 OCCUPANTS 28,000 BTU/HR (7,050 KCAL/HR) SOLAR LOAD
- ④ 80°F (26.7°C) CABIN TEMP. HEAT LOADS SAME AS ③, ABOVE
- ⑤⑥⑦ 75°F (23.9°C) CABIN TEMP. NO OCCUPANTS OR HEAT LOADS

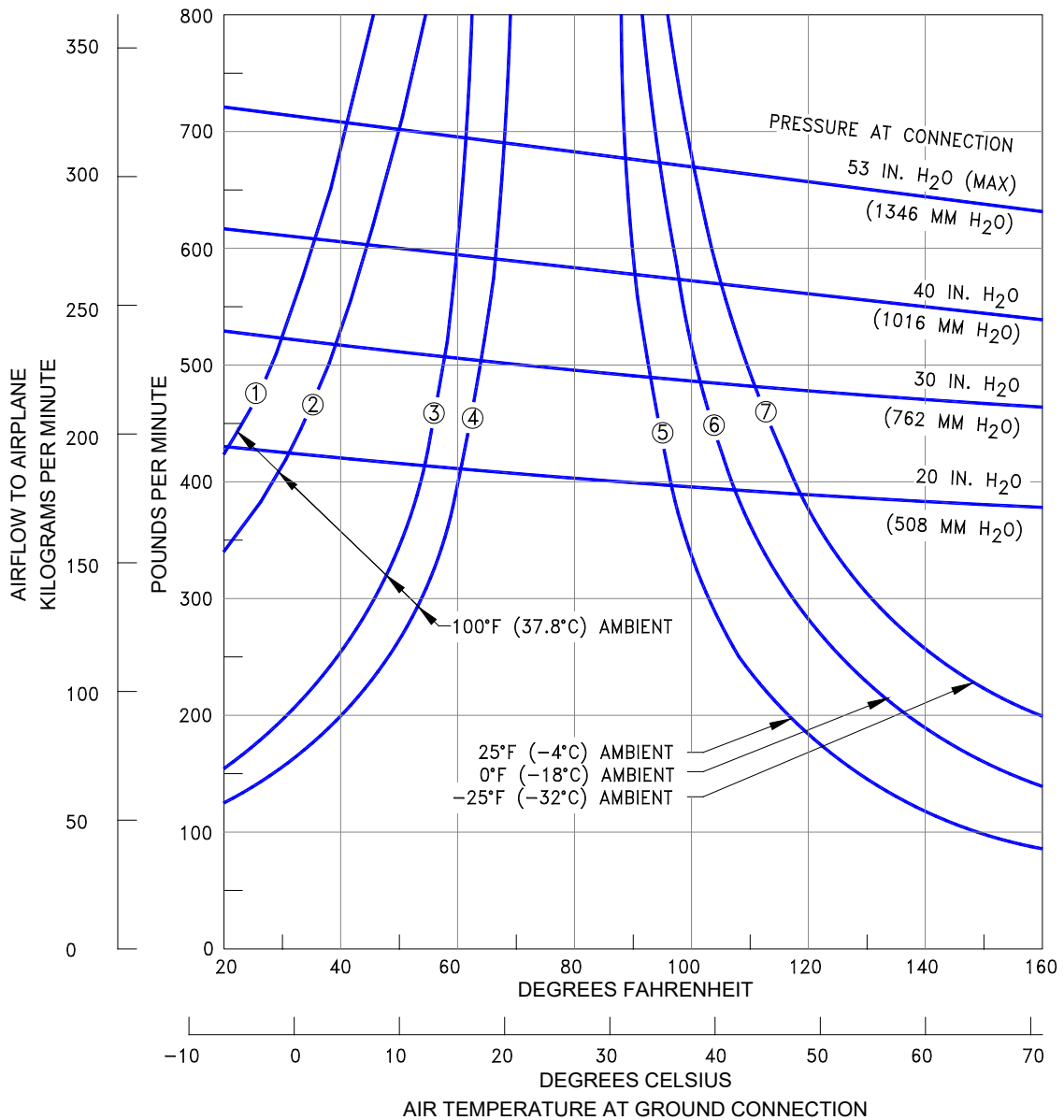

D6-58326-1

REV E

September 2023

5-22

5.8 GROUND TOWING REQUIREMENTS

5.8.1 Ground Towing Requirements - English Units: Model 747-400

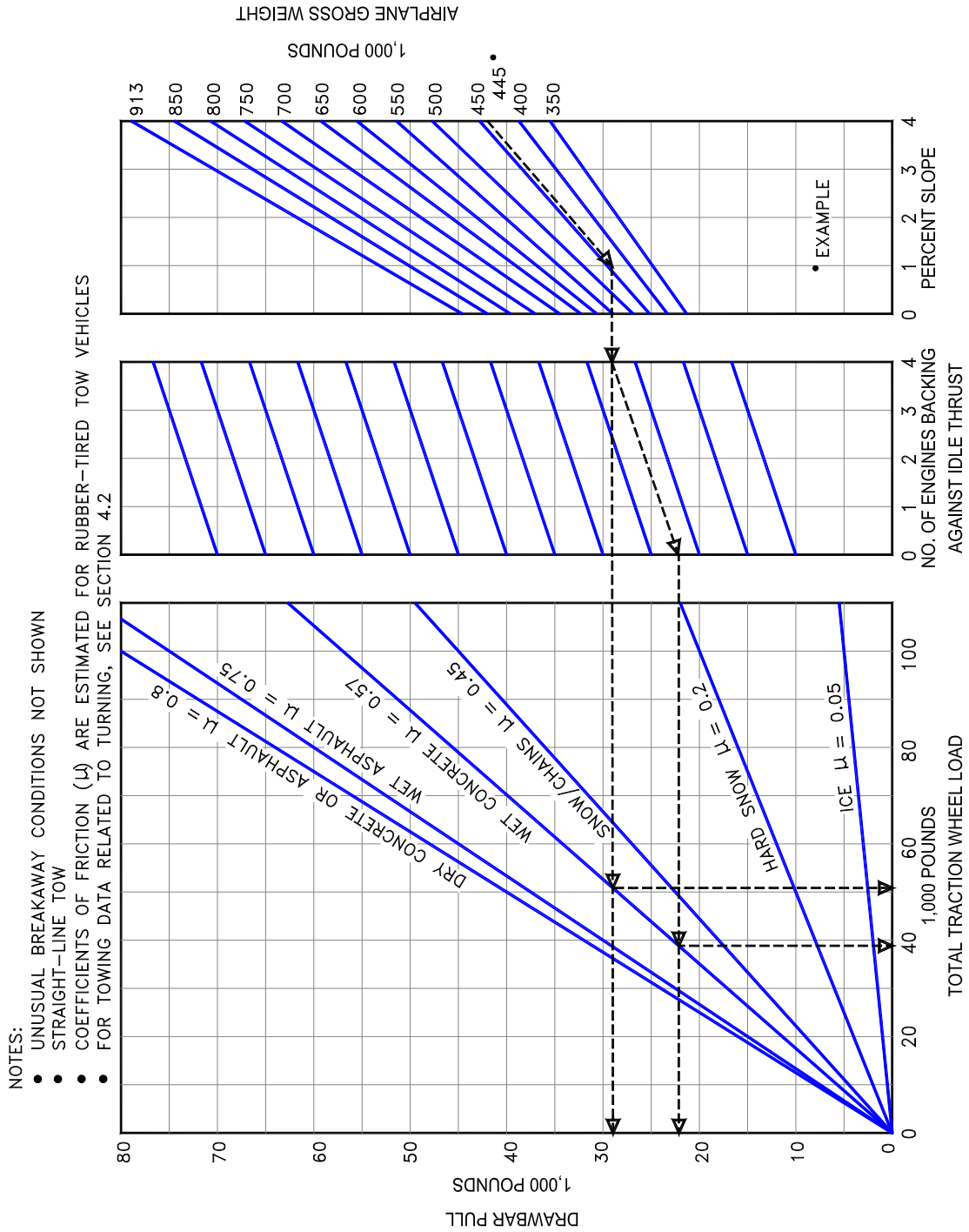

D6-58326-1

5.8.2 Ground Towing Requirements - Metric Units: Model 747-400

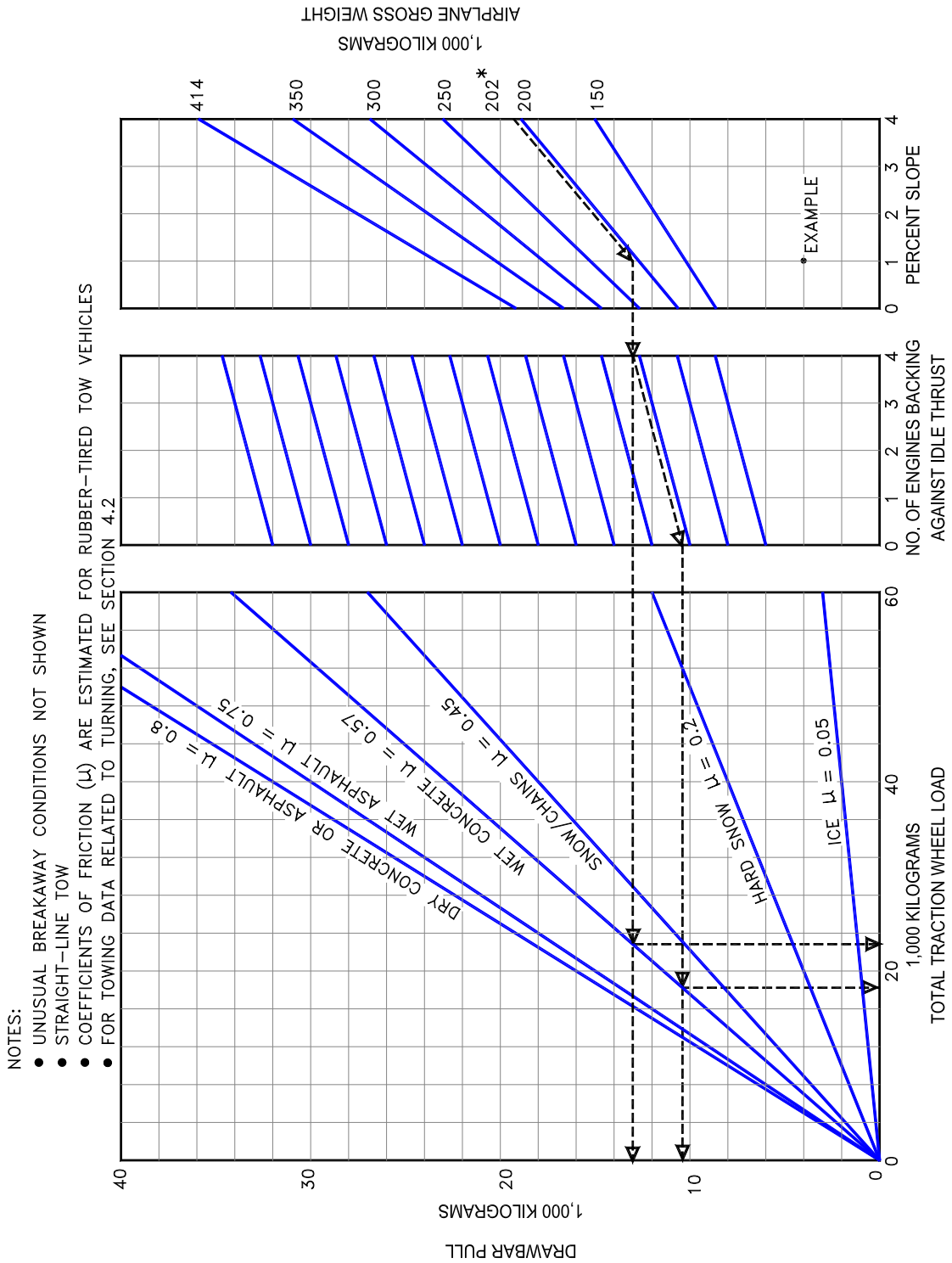

D6-58326-1

6.0 JET ENGINE WAKE AND NOISE DATA

6.1 JET ENGINE EXHAUST VELOCITIES AND TEMPERATURES

This section shows exhaust velocity and temperature contours aft of the 747-400 airplane. The contours were calculated from a standard computer analysis using three-dimensional viscous flow equations with mixing of primary, fan, and free-stream flow. The presence of the ground plane is included in the calculations as well as engine tilt and toe-in. Mixing of flows from the engines is also calculated. The analysis does not include thermal buoyancy effects which tend to elevate the jet wake above the ground plane. The buoyancy effects are considered to be small relative to the exhaust velocity and therefore are not included.

The graphs show jet wake velocity and temperature contours for a representative engine. The results are valid for sea level, static, standard day conditions. The effect of wind on jet wakes was not included. There is evidence to show that a downwind or an upwind component does not simply add or subtract from the jet wake velocity, but rather carries the whole envelope in the direction of the wind. Crosswinds may carry the jet wake contour far to the side at large distances behind the airplane.

6.1.1 Jet Engine Exhaust Velocity Contours – Idle Thrust: Model 747-400

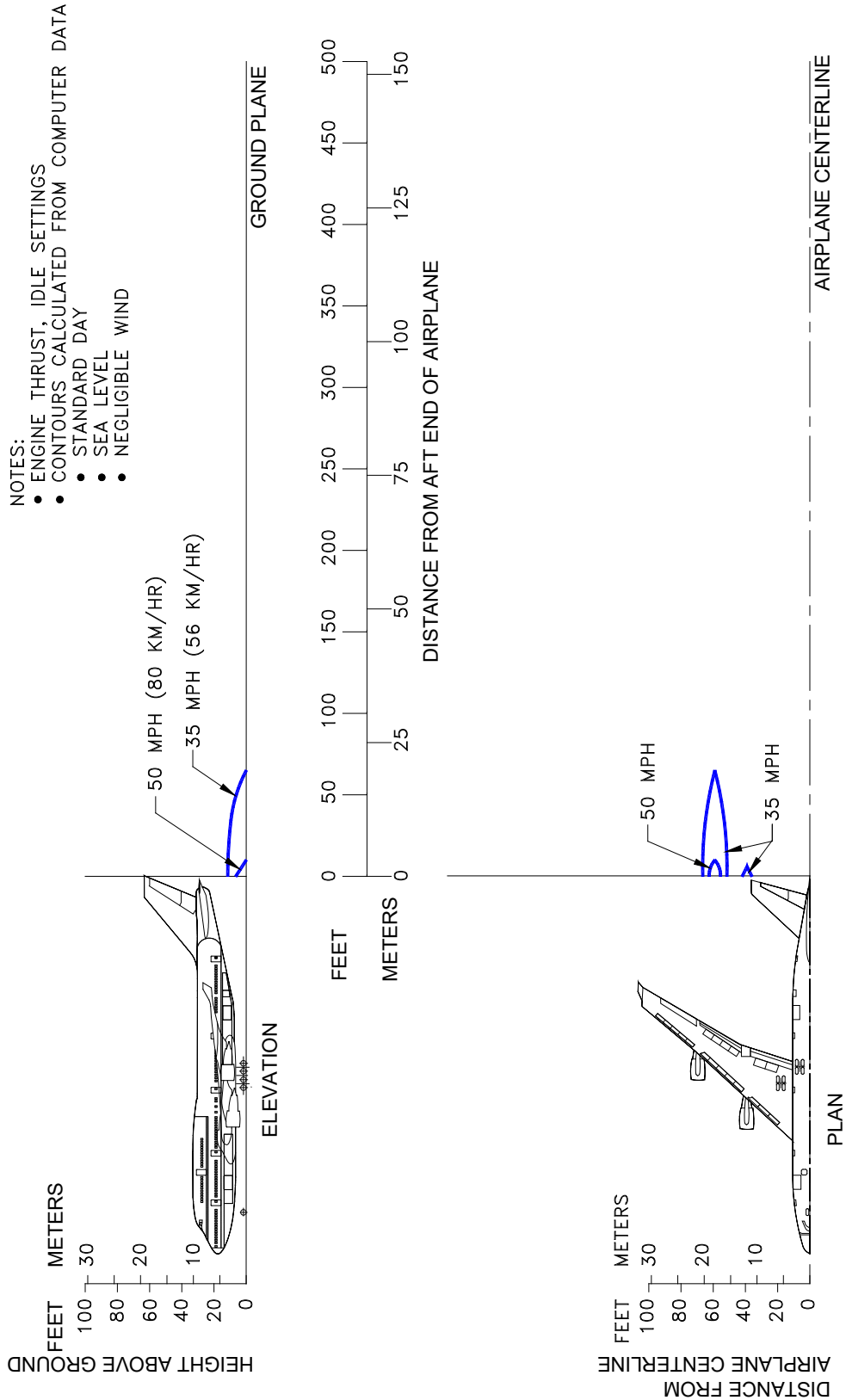

D6-58326-1

6.1.2 Jet Engine Exhaust Velocity Contours – Breakaway Thrust – Level Pavement: Model 747-400, -400 Combi, -400 Domestic, -400 Freighter

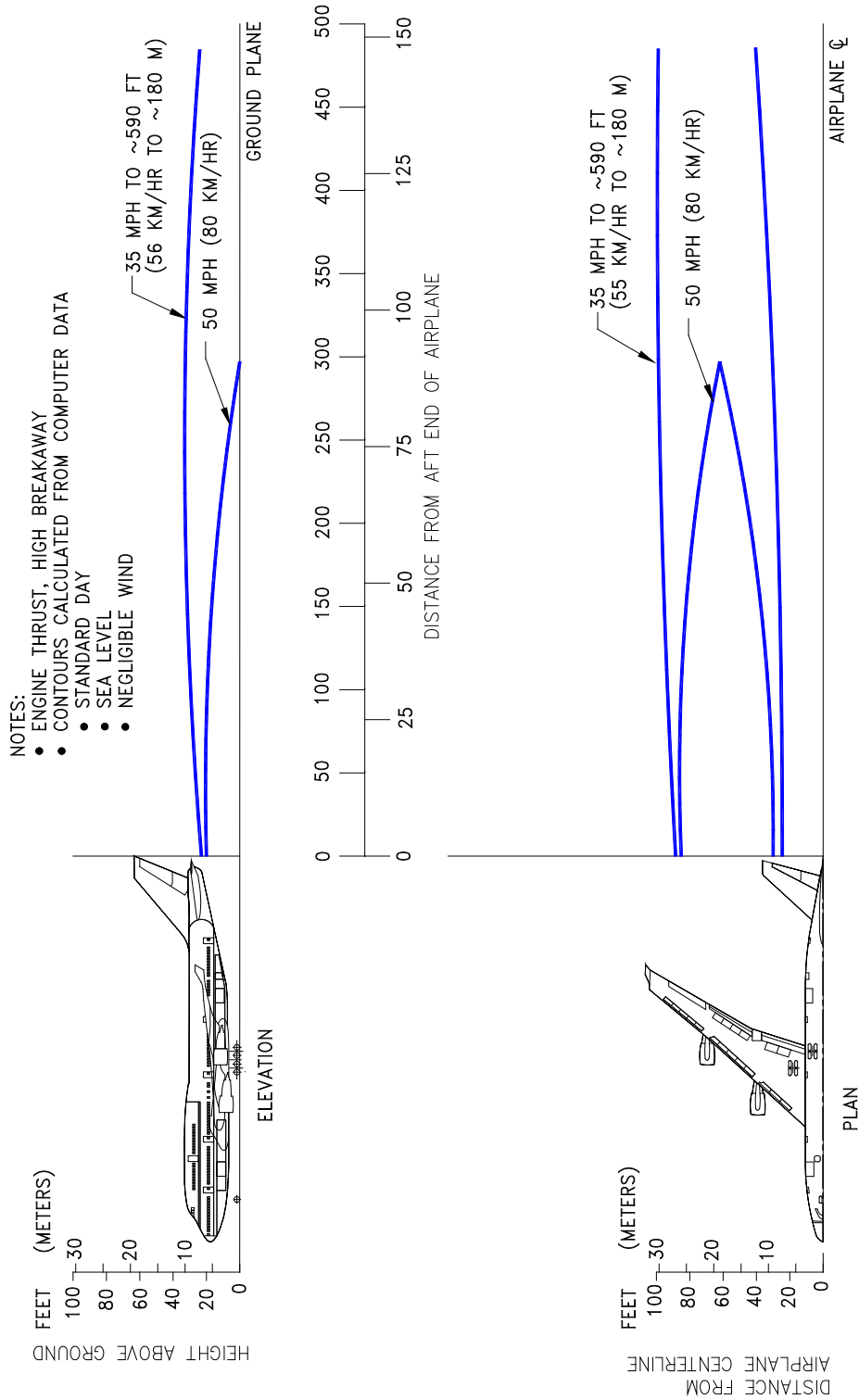

D6-58326-1

6.1.3 Jet Engine Exhaust Velocity Contours – Breakaway Thrust - Level Pavement Upslope: Model 747-400ER, -400ER Freighter

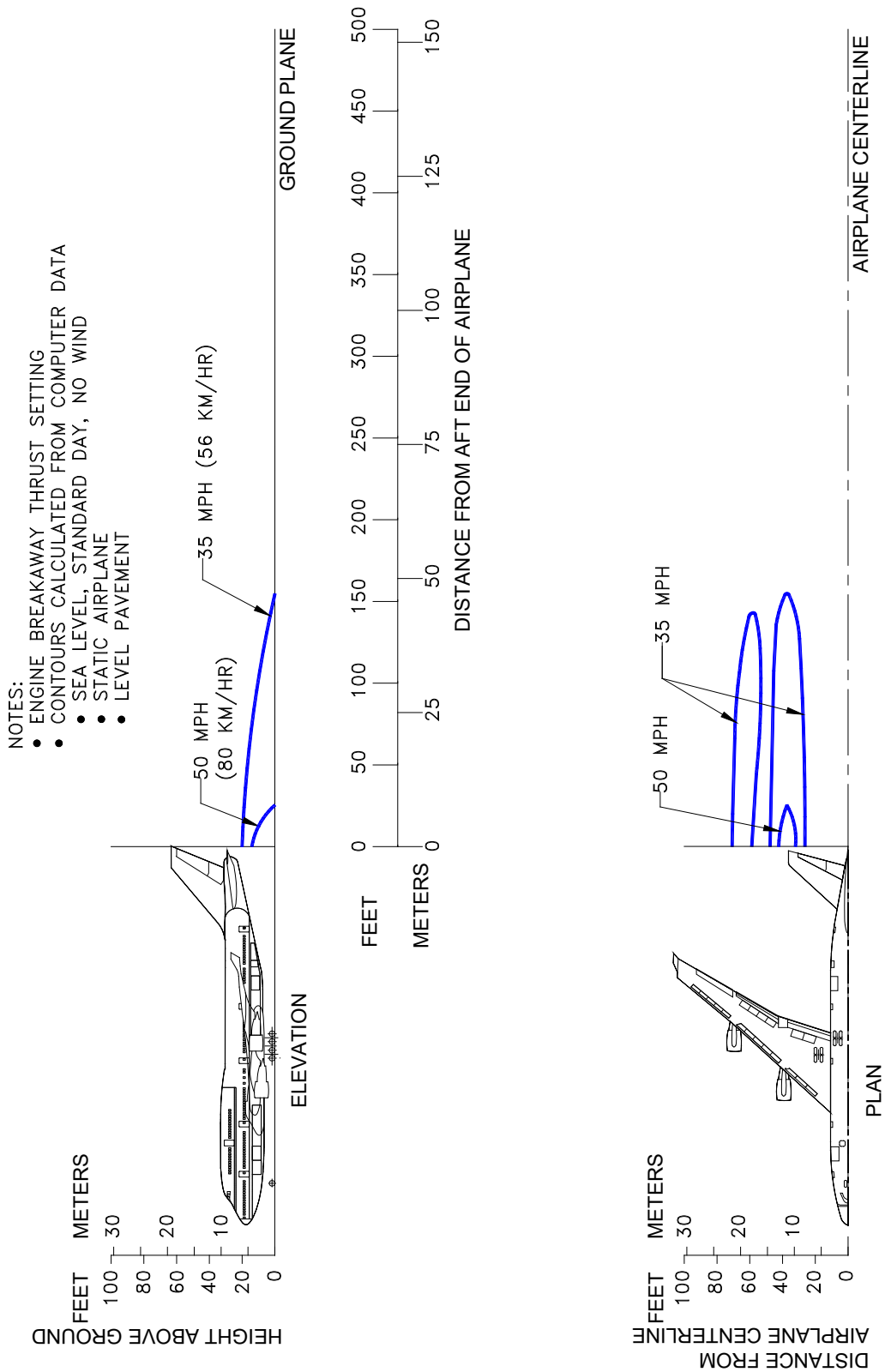

6.1.4 Jet Engine Exhaust Velocity Contours - Breakaway Thrust - 1.5% Pavement Upslope: Model 747-400ER, -400ER Freighter

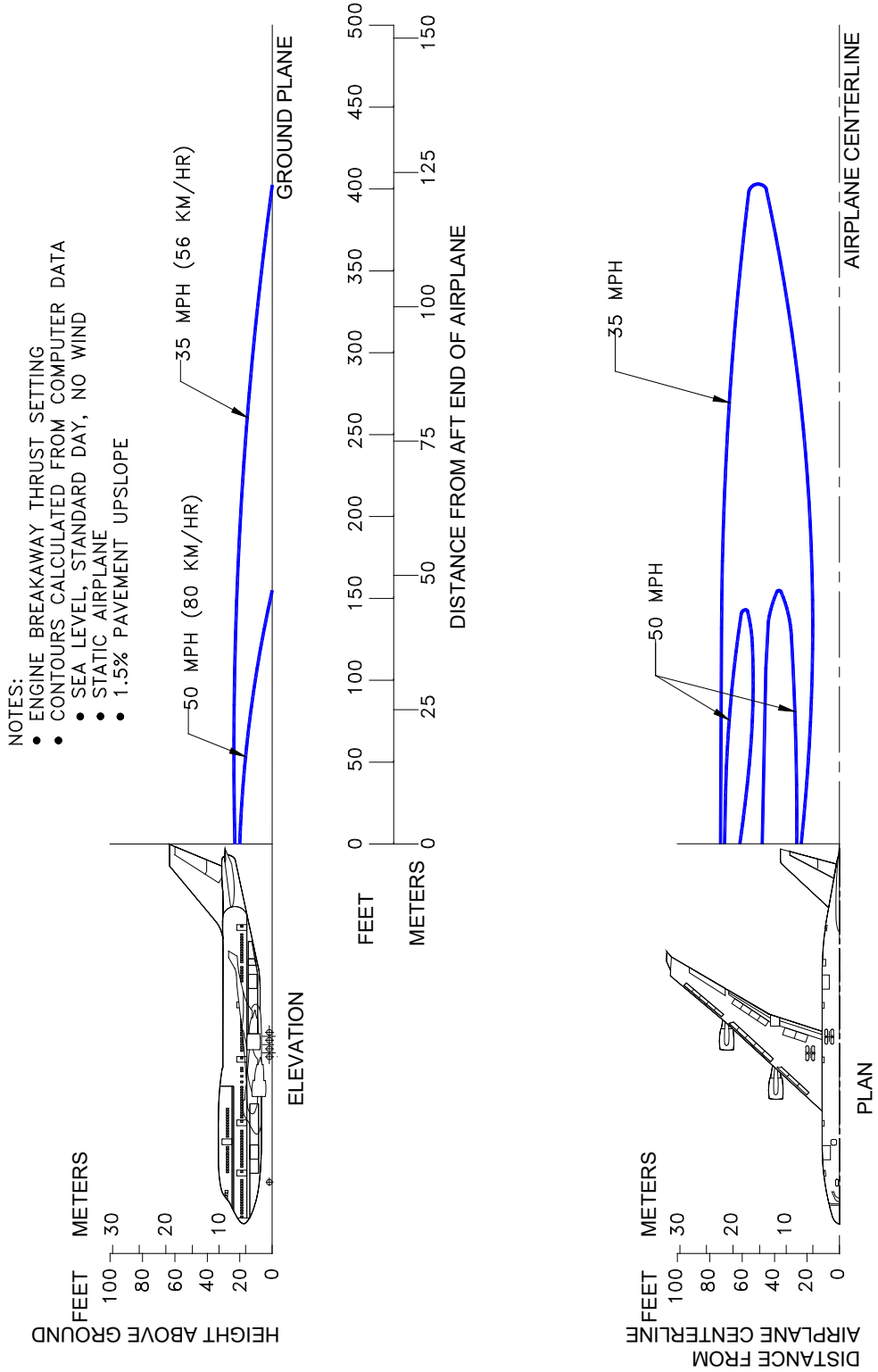

D6-58326-1

6.1.5 Jet Engine Exhaust Velocity Contours - Takeoff Thrust: Model 747-400

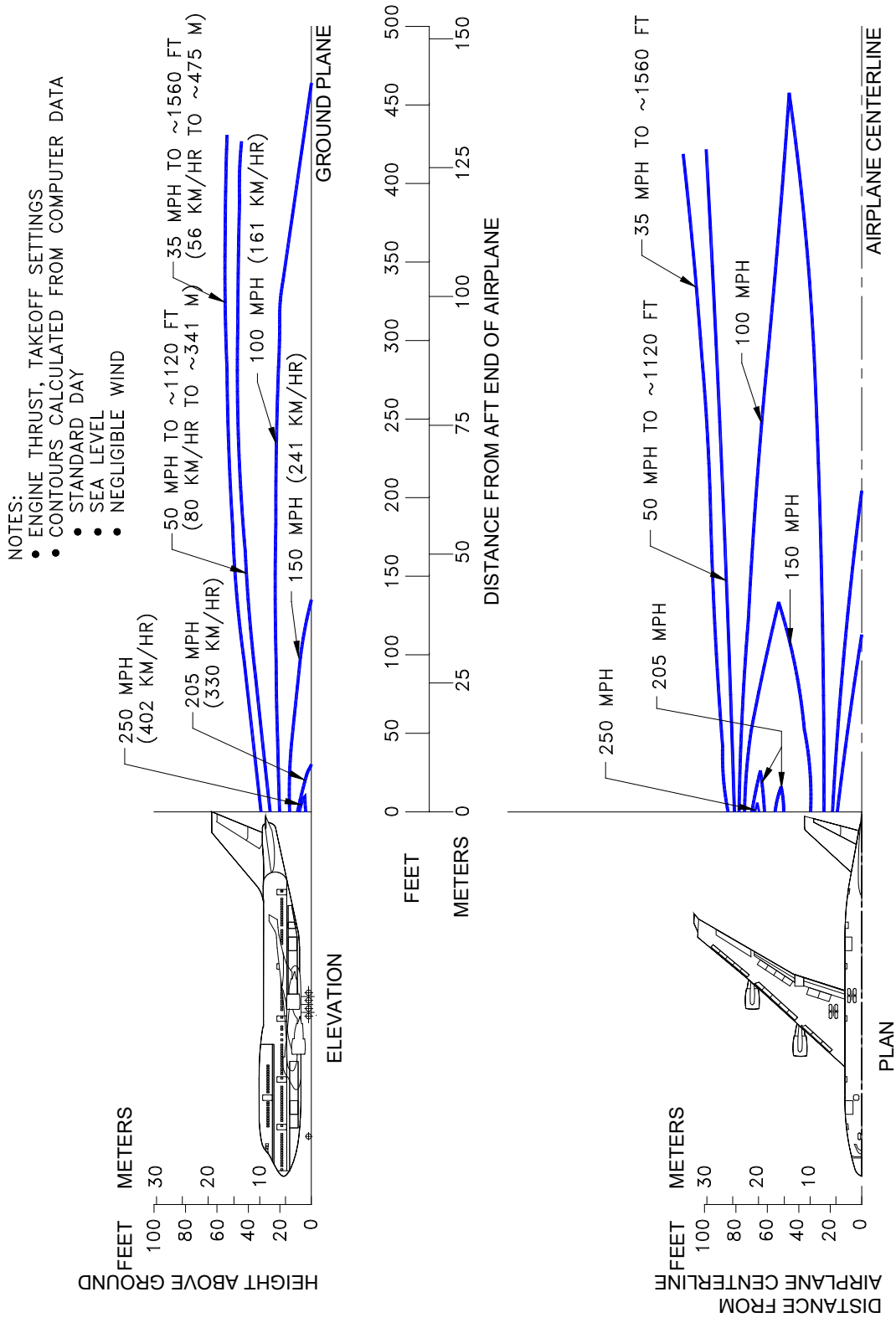

D6-58326-1

6.1.6 Jet Engine Exhaust Temperature Contours – Idle/Breakaway Thrust: Model 747-400

Temperature contours for idle/breakaway power conditions are not shown as the maximum temperature aft of the 747-400 is predicated to be less than 100° F (38° C) for standard day conditions of 59° F (15° C).

6.1.7 Jet Engine Exhaust Temperature Contours - Takeoff Thrust: Model 747-400

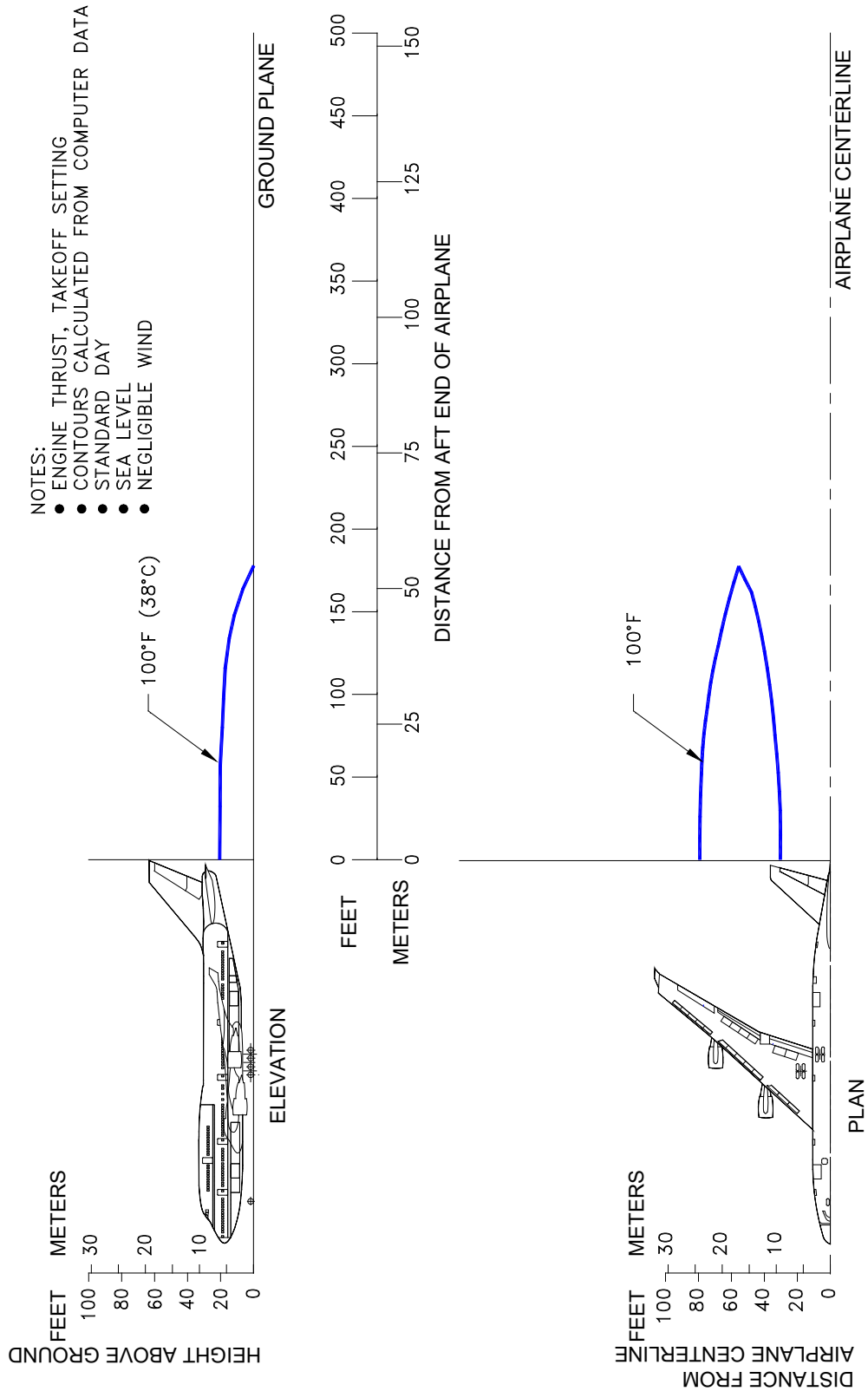

D6-58326-1

6.1.8 Inlet Hazard Areas: All Models

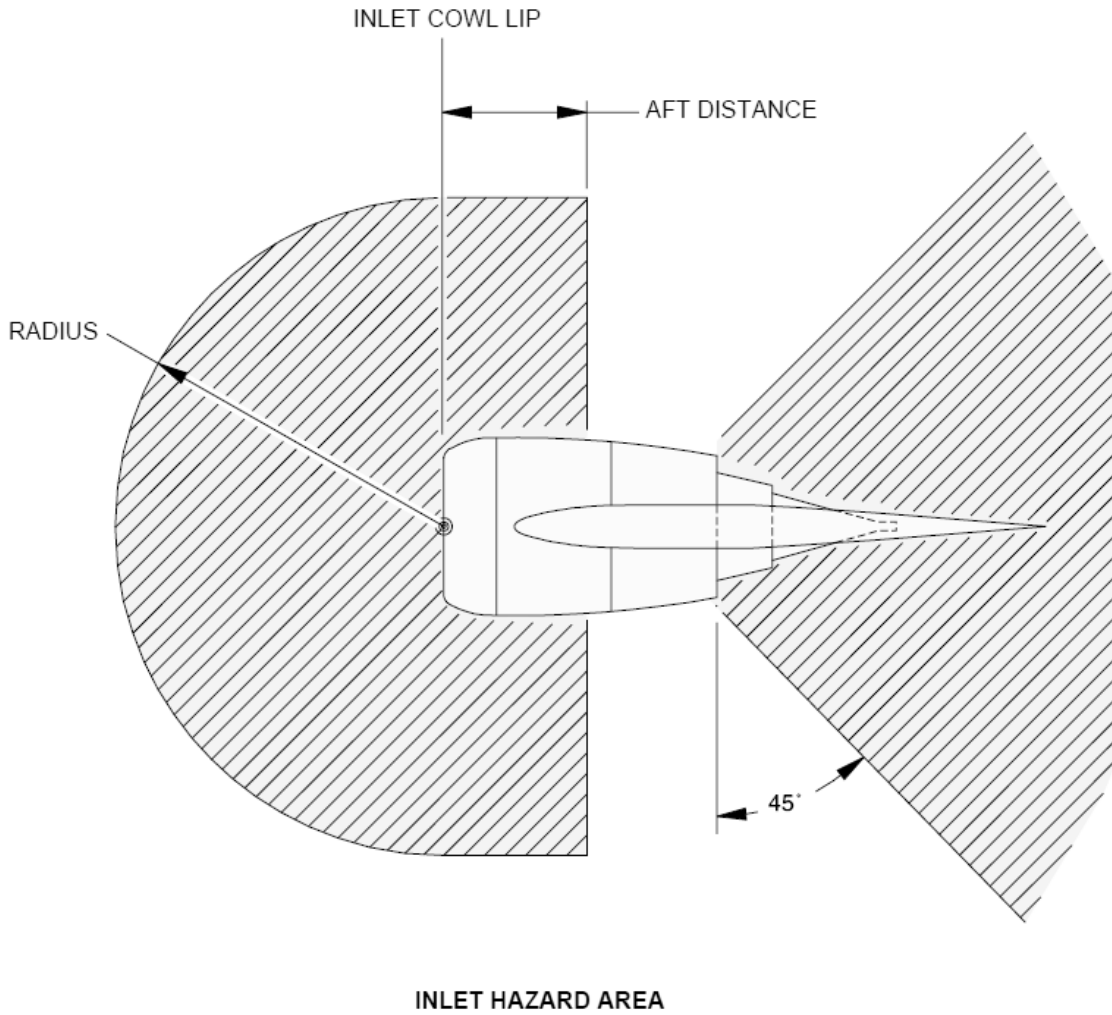

	RADIUS		AFT DISTANCE	
	IDLE THRUST	7.0 FT	2.1 M	5.0 FT
BREAKAWAY THRUST	18.0 FT	5.5 M	9.0 FT	2.7 M
TAKEOFF THRUST	18.0 FT	5.5 M	9.0 FT	2.7 M

6.2 AIRPORT AND COMMUNITY NOISE

Airport noise is of major concern to the airport and community planner. The airport is a major element in the community's transportation system and, as such, is vital to its growth. However, the airport must also be a good neighbor, and this can be accomplished only with proper planning. Since aircraft noise extends beyond the boundaries of the airport, it is vital to consider the impact on surrounding communities. Many means have been devised to provide the planner with a tool to estimate the impact of airport operations. Too often they oversimplify noise to the point where the results become erroneous. Noise is not a simple subject; therefore, there are no simple answers.

The cumulative noise contour is an effective tool. However, care must be exercised to ensure that the contours, used correctly, estimate the noise resulting from aircraft operations conducted at an airport.

The size and shape of the single-event contours, which are inputs into the cumulative noise contours, are dependent upon numerous factors. They include the following:

1. Operational Factors
 - a. Aircraft Weight-Aircraft weight is dependent on distance to be traveled, en route winds, payload, and anticipated aircraft delay upon reaching the destination.
 - b. Engine Power Settings-The rates of ascent and descent and the noise levels emitted at the source are influenced by the power setting used.
 - c. Airport Altitude-Higher airport altitude will affect engine performance and thus can influence noise.
2. Atmospheric Conditions-Sound Propagation
 - a. Wind-With stronger headwinds, the aircraft can take off and climb more rapidly relative to the ground. Also, winds can influence the distribution of noise in surrounding communities.
 - b. Temperature and Relative Humidity-The absorption of noise in the atmosphere along the transmission path between the aircraft and the ground observer varies with both temperature and relative humidity.
3. Surface Condition-Shielding, Extra Ground Attenuation (EGA)
 - a. Terrain-If the ground slopes down after takeoff or up before landing, noise will be reduced since the aircraft will be at a higher altitude above ground. Additionally, hills, shrubs, trees, and large buildings can act as sound buffers.

All these factors can alter the shape and size of the contours appreciably. To demonstrate the effect of some of these factors, estimated noise level contours for two different operating conditions are shown below. These contours reflect a given noise level upon a ground level plane at runway elevation.

Condition 1

Landing		Takeoff	
Maximum Design	Landing	Maximum Design	Takeoff
Weight		Weight	
10-knot Headwind		Zero Wind	
3° Approach		84 °F (29 °C)	
84 °F (29 °C)		Humidity 15%	
Humidity 15%			

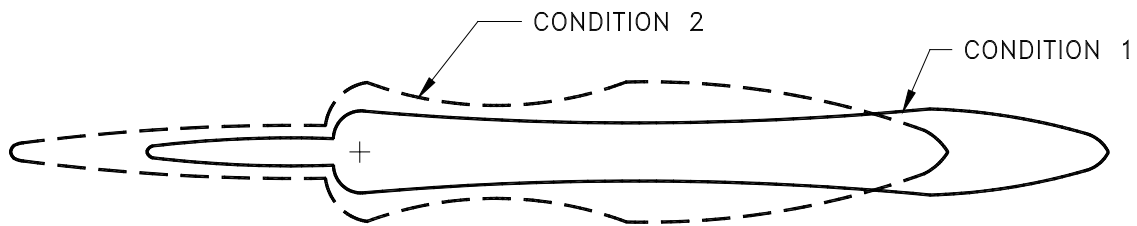

Condition 2

Landing		Takeoff	
85% of Maximum Design	Landing	80% of Maximum Design	Takeoff
Weight		Weight	
10-knot Headwind		10-knot Headwind	
3° Approach		59 °F (15 °C)	
59 °F (15 °C)		Humidity 70%	
Humidity 70%			

As indicated from these data, the contour size varies substantially with operating and atmospheric conditions. Most aircraft operations are, of course, conducted at less than maximum gross weights because average flight distances are much shorter than maximum aircraft range capability and average load factors are less than 100%. Therefore, in developing cumulative contours for planning purposes, it is recommended that the airlines serving a particular city be contacted to provide operational information.

In addition, there are no universally accepted methods for developing aircraft noise contours or for relating the acceptability of specific zones to specific land uses. It is therefore expected that noise contour data for particular aircraft and the impact assessment methodology will be changing. To ensure that the best currently available information of this type is used in any planning study, it is recommended that it be obtained directly from the Office of Environmental Quality in the Federal Aviation Administration in Washington, D.C.

It should be noted that the contours shown herein are only for illustrating the impact of operating and atmospheric conditions and do not represent the single-event contour of the family of aircraft described in this document. It is expected that the cumulative contours will be developed as required by planners using the data and methodology applicable to their specific study.

7.0 PAVEMENT DATA

7.1 GENERAL INFORMATION

A brief description of the pavement charts that follow will help in their use for airport planning. Each airplane configuration is depicted with a minimum range of six loads imposed on the main landing gear to aid in interpolation between the discrete values shown. All curves for any single chart represent data based on rated loads and tire pressures considered normal and acceptable by current aircraft tire manufacturer's standards. Tire pressures, where specifically designated on tables and charts, are at values obtained under loaded conditions as certificated for commercial use.

Section 7.2 presents basic data on the landing gear footprint configuration, maximum design taxi loads, and tire sizes and pressures.

Maximum pavement loads for certain critical conditions at the tire-to-ground interface are shown in Section 7.3, with the tires having equal loads on the struts.

Pavement requirements for commercial airplanes are customarily derived from the static analysis of loads imposed on the main landing gear struts. The chart in Section 7.4 is provided in order to determine these loads throughout the stability limits of the airplane at rest on the pavement. These main landing gear loads are used as the point of entry to the pavement design charts, interpolating load values where necessary.

The flexible pavement design curves (Section 7.5) are based on procedures set forth in Instruction Report No. S-77-1, "Procedures for Development of CBR Design Curves," dated June 1977, and as modified according to the methods described in ICAO Aerodrome Design Manual, Part 3, Pavements, 2nd Edition, 1983, Section 1.1 (The ACN-PCN Method), and utilizing the alpha factors approved by ICAO in October 2007. Instruction Report No. S-77-1 was prepared by the U.S. Army Corps of Engineers Waterways Experiment Station, Soils and Pavements Laboratory, Vicksburg, Mississippi. The line showing 10,000 coverages is used to calculate Aircraft Classification Number (ACN).

The following procedure is used to develop the curves, such as shown in Section 7.5:

1. Having established the scale for pavement depth at the bottom and the scale for CBR at the top, an arbitrary line is drawn representing 6,000 annual departures.
2. Values of the aircraft gross weight are then plotted.
3. Additional annual departure lines are drawn based on the load lines of the aircraft gross weights already established.
4. An additional line representing 10,000 coverages (used to calculate the flexible pavement Aircraft Classification Number) is also placed.

All Load Classification Number (LCN) curves (Sections 7.6 and 7.8) have been developed from a computer program based on data provided in International Civil Aviation

Organization (ICAO) document 9157-AN/901, Aerodrome Design Manual, Part 3, "Pavements," First Edition, 1977. LCN values are shown directly for parameters of weight on main landing gear, tire pressure, and radius of relative stiffness (l) for rigid pavement or pavement thickness or depth factor (h) for flexible pavement.

Rigid pavement design curves (Section 7.7) have been prepared with the Westergaard equation in general accordance with the procedures outlined in the Design of Concrete Airport Pavement (1955 edition) by Robert G. Packard, published by the Portland Cement Association, 5420 Old Orchard Road, Skokie, Illinois 60077-1083. These curves are modified to the format described in the Portland Cement Association publication XP6705-2, Computer Program for Airport Pavement Design (Program PDILB), 1968, by Robert G. Packard.

The following procedure is used to develop the rigid pavement design curves shown in Section 7.7:

1. Having established the scale for pavement thickness to the left and the scale for allowable working stress to the right, an arbitrary load line is drawn representing the main landing gear maximum weight to be shown.
2. Values of the subgrade modulus (k) are then plotted.
3. Additional load lines for the incremental values of weight on the main landing gear are drawn on the basis of the curve for $k = 300$, already established.

The rigid pavement design curves (Section 7.9) have been developed based on methods used in the FAA Advisory Circular AC 150/5320-6C, September 14, 1988. The following procedure is used to develop the curves, such as shown in Section 7.9:

1. Having established the scale for pavement flexure strength on the left and temporary scale for pavement thickness on the right, an arbitrary load line is drawn representing the main landing gear maximum weight to be shown at 5,000 coverages.
2. Values of the subgrade modulus (k) are then plotted.
3. Additional load lines for the incremental values of weight are then drawn on the basis of the subgrade modulus curves already established.

The permanent scale for the rigid-pavement thickness is then placed. Lines for other than 5,000 coverages are established based on the aircraft pass-to-coverage ratio.

The ACN/PCN system (Section 7.10) as referenced in ICAO document 9157-AN/901, Aerodrome Design Manual, Part 3, Pavements, Second Edition 1983, provides a standardized international airplane/pavement rating system replacing the various S, T, TT, LCN, AUW, ISWL, etc., rating systems used throughout the world. ACN is the Aircraft Classification Number and PCN is the Pavement Classification Number. An aircraft having an ACN equal to or less than the PCN can operate on the pavement subject to any limitation on the tire pressure. Numerically, the ACN is two times the derived single-wheel load expressed in thousands of kilograms, where the derived single wheel load is defined as the load on a single tire inflated to 181 psi (1.25 MPa) that would have the same pavement requirements as the aircraft. Computationally, the ACN/PCN system uses the PCA program PDILB for rigid pavements and S-77-1 for flexible pavements to calculate ACN values. The method of pavement evaluation is left up to the airport with the results of their evaluation presented as follows:

PCN	PAVEMENT TYPE	SUBGRADE CATEGORY	TIRE PRESSURE CATEGORY	EVALUATION METHOD
	R = Rigid	A = High	W = No Limit	T = Technical
	F = Flexible	B = Medium	X = To 254 psi (1.75 MPa)	U = Using Aircraft
		C = Low	Y = To 181 psi (1.25 MPa)	
		D = Ultra Low	Z = To 73 psi (0.5 MPa)	

Section 7.10.1 shows the aircraft ACN values for flexible pavements. The four subgrade categories are:

Code A - High Strength - CBR 15

Code B - Medium Strength - CBR 10

Code C - Low Strength - CBR 6

Code D - Ultra Low Strength - CBR 3

Section 7.10.2 shows the aircraft ACN values for rigid pavements. The four subgrade categories are:

Code A - High Strength, $k = 550 \text{ pci (150 MN/m}^3\text{)}$

Code B - Medium Strength, $k = 300 \text{ pci (80 MN/m}^3\text{)}$

Code C - Low Strength, $k = 150 \text{ pci (40 MN/m}^3\text{)}$

Code D - Ultra Low Strength, $k = 75 \text{ pci (20 MN/m}^3\text{)}$

7.2 LANDING GEAR FOOTPRINT

7.2.1 Landing Gear Footprint: Model 747-400, -400 Combi, -400 Domestic

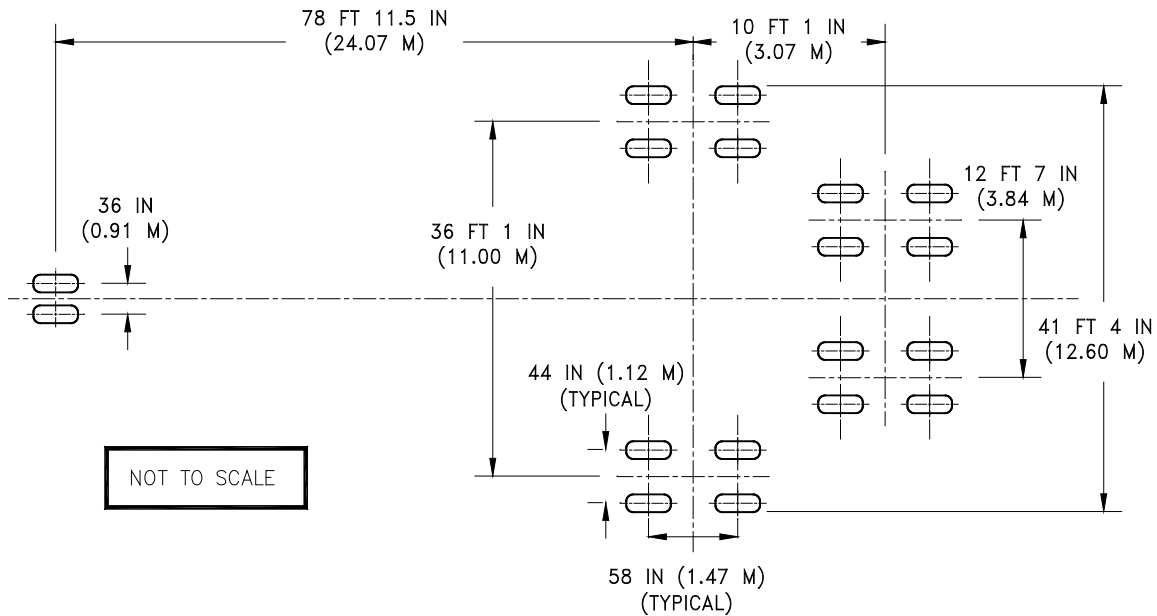

	UNITS	747-400D	747-400, 747-400COMBI		
MAXIMUM DESIGN TAXI WEIGHT	LB	603,000 TO 613,500	803,000	836,000 TO 853,000	873,000 TO 877,000
	KG	273,517 TO 278,279	364,235	379,204 TO 386,915	395,987 TO 397,801
PERCENT OF WEIGHT ON MAIN GEAR	%	SEE SECTION 7.4			
NOSE GEAR TIRE SIZE	IN.	49X17, 32 PR (1)	49X17, 32 PR (2)		
NOSE GEAR TIRE PRESSURE	PSI	150	200		
	KG/CM ²	10.55 (1)	14.06 (2)		
MAIN GEAR TIRE SIZE	IN.	H49 X 19.0 - 22, 24 PR	H49 X 19.0 - 22, 32 PR		
MAIN GEAR TIRE PRESSURE (3)	PSI	150	190	195	200
	KG/CM ²	10.55	13.36	13.71	14.06

NOTES:

- OPTION: 49X19.0-20 32PR OR 34PR AT 150 PSI (10.55 KG/CM²) OR H49X19.0-22, 24PR AT 150 PSI (10.55 KG/CM²).
- OPTION: 49X19.0-20 32PR OR 34PR AT 185 PSI (13.01 KG/CM²) OR H49X19.0-22, 32PR AT 175 PSI (12.30 KG/CM²).
- COLD, LOADED PRESSURES SHOWN. TOLERANCE = +5/-0 PSI.

D6-58326-1

REV E

September 2023

7-4

7.2.2 Landing Gear Footprint: Model 747-400 Freighter

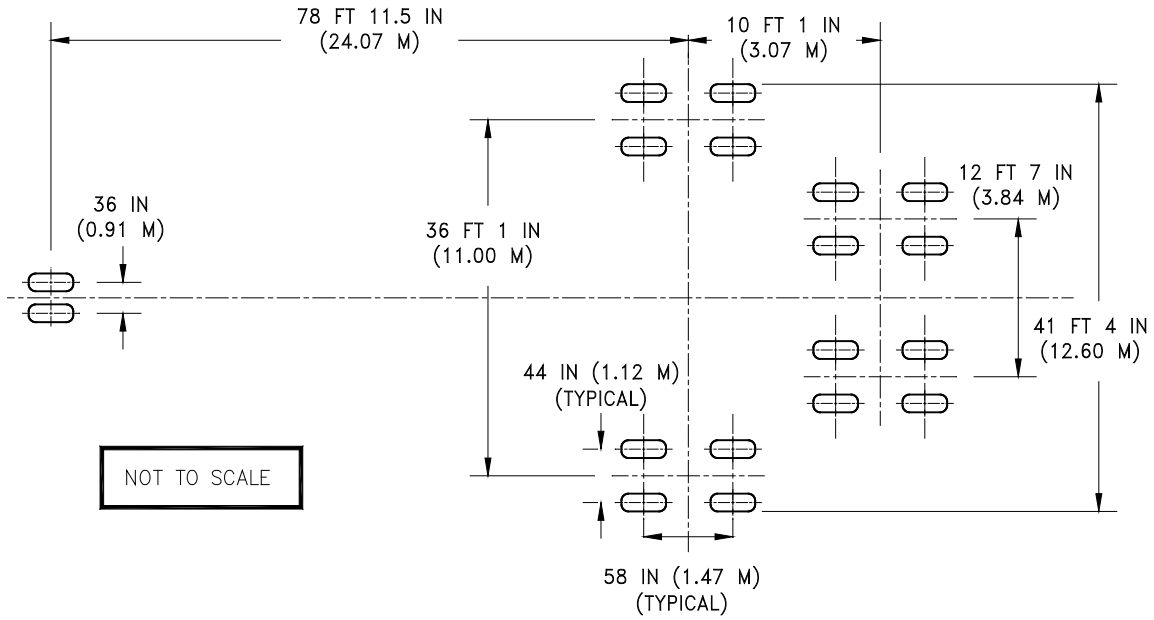

	UNITS	747-400F		
MAXIMUM DESIGN TAXI WEIGHT	LB	803,000	836,000 TO 853,000	873,000 TO 877,000
	KG	364,235	379,204 TO 386,915	375,987 TO 397,801
PERCENT OF WEIGHT ON MAIN GEAR	%	SEE SECTION 7.4		
NOSE GEAR TIRE SIZE	IN.	H49 X 19.0 - 22, 32PR		
NOSE GEAR TIRE PRESSURE	PSI	175		
	KG/CM ²	12.30		
MAIN GEAR TIRE SIZE	IN.	H49 X 19.0 - 22, 32 PR		
MAIN GEAR TIRE PRESSURE	PSI	190	195	200
	KG/CM ²	13.36	13.71	14.06

D6-58326-1

REV E

September 2023

7-5

7.2.3 Landing Gear Footprint: Model 747-400ER, -400ER Freighter

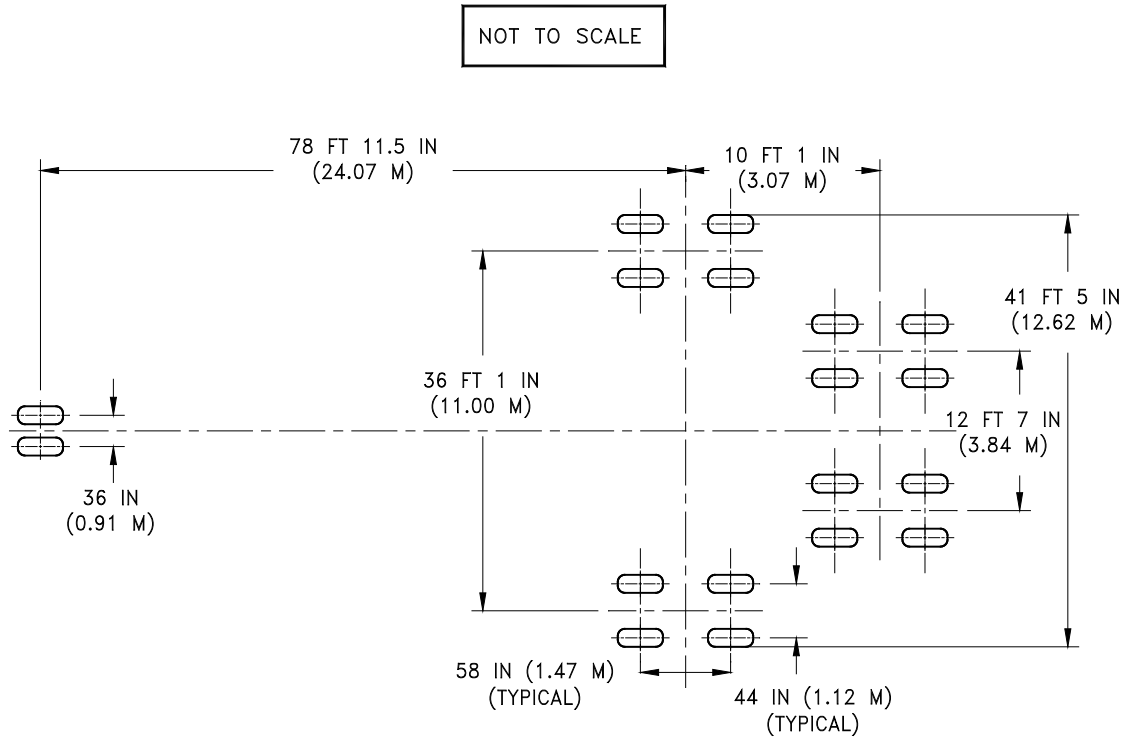

	UNITS	747-400ER	747-400ER FREIGHTER
MAXIMUM DESIGN TAXI WEIGHT	LB	913,000	913,000
	KG	414,130	414,130
PERCENT OF WEIGHT ON MAIN GEAR	%	SEE SECTION 7.4	
NOSE GEAR TIRE SIZE	IN.	50 X 20.0 R 22, 34 PR	50 X 20.0 R22, 34 PR
NOSE GEAR TIRE PRESSURE	PSI	190	190
	KG/CM ²	13.36	13.36
MAIN GEAR TIRE SIZE	IN.	50 X 20.0 R 22, 34 PR	50 X 20.0 R22, 34 PR
MAIN GEAR TIRE PRESSURE	PSI	230	230
	KG/CM ²	16.17	16.17

D6-58326-1

REV E

September 2023

7-6

7.3 MAXIMUM PAVEMENT LOADS: MODEL 747-400

- V_{NG} = MAXIMUM VERTICAL NOSE GEAR GROUND LOAD AT MOST FORWARD CENTER OF GRAVITY
 V_{MG} = MAXIMUM VERTICAL MAIN GEAR GROUND LOAD AT MOST AFT CENTER OF GRAVITY
 H = MAXIMUM HORIZONTAL GROUND LOAD FROM BRAKING

- NOTES:** 1. ALL LOADS CALCULATED USING AIRPLANE MAXIMUM DESIGN TAXI WEIGHT
 2. ALL CALCULATED VALUES AND CONVERSIONS ROUNDED TO NEAREST 100 LB AND 50 KG.

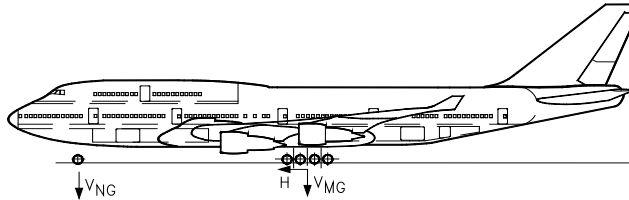

AIRPLANE MODEL	UNITS	MAX DESIGN TAXI WEIGHT	V_{NG}		V_{MG} PER STRUT (4)	H PER STRUT (4)	
			STATIC AT MOST FWD C.G.	STATIC + BRAKING 10 FT/SEC ² DECEL	MAX LOAD AT STATIC AFT C.G.	STEADY BRAKING 10 FT/SEC ² DECEL	AT INSTANTANEOUS BRAKING (m = 0.8)
747-400	LB	803,000	93,300	138,200	191,500	62,300	153,200
	KG	364,250	42,350	62,700	86,850	28,300	69,500
747-400*	LB	803,000	65,900	110,800	191,500	62,300	153,200
	KG	364,250	29,900	50,250	86,850	28,300	69,500
747-400	LB	836,000	93,000	139,900	197,300	64,900	157,800
	KG	379,200	42,200	63,450	89,500	29,450	71,600
747-400*	LB	836,000	68,100	114,800	197,300	64,900	157,800
	KG	379,200	30,850	52,100	89,500	29,450	71,600
747-400	LB	853,000	92,200	139,900	200,300	66,200	160,200
	KG	386,900	41,800	63,450	90,850	30,050	72,650
747-400*	LB	853,000	68,600	116,300	200,300	66,200	160,200
	KG	386,900	31,100	52,750	90,850	30,050	72,650
747-400	LB	873,000	68,800	117,700	204,500	67,800	163,600
	KG	396,000	31,200	53,400	92,750	30,750	74,200
747-400	LB	877,000	64,000	114,000	204,600	68,100	163,700
	KG	397,800	29,000	51,700	92,800	30,900	74,250
747-400F	LB	873,000	80,100	116,200	204,500	67,800	163,600
	KG	396,000	36,350	52,700	92,750	30,750	74,200
747-400F*	LB	873,000	67,400	116,200	204,500	67,800	163,600
	KG	396,000	30,550	52,700	92,750	30,750	74,200
747-400F	LB	877,000	76,500	127,900	204,600	68,100	163,700
	KG	397,800	34,700	58,000	92,800	30,900	74,250
747-400F*	LB	877,000	67,400	118,800	204,600	68,100	163,700
	KG	397,800	30,550	53,900	92,800	30,900	74,250
747-400D	LB	603,000	70,100	103,800	145,200	46,800	116,200
	KG	273,500	31,800	47,100	65,900	21,250	52,700
747-400D	LB	613,500	71,300	105,600	147,800	47,600	118,200
	KG	278,300	32,350	47,900	67,050	21,600	53,600
747-400ER	LB	913,000	71,950	122,400	213,600	70,900	170,900
	KG	414,150	32,650	55,550	96,900	32,150	77,500
FREIGHTER	LB	913,000	77,300	130,950	213,600	70,900	170,900
	KG	414,150	35,050	59,400	96,900	32,150	77,500

* AIRPLANE WITH TAIL TANK FUEL

7.4 LANDING GEAR LOADING ON PAVEMENT

7.4.1 Landing Gear Loading on Pavement: Model 747-400, -400 Combi, -400 Domestic

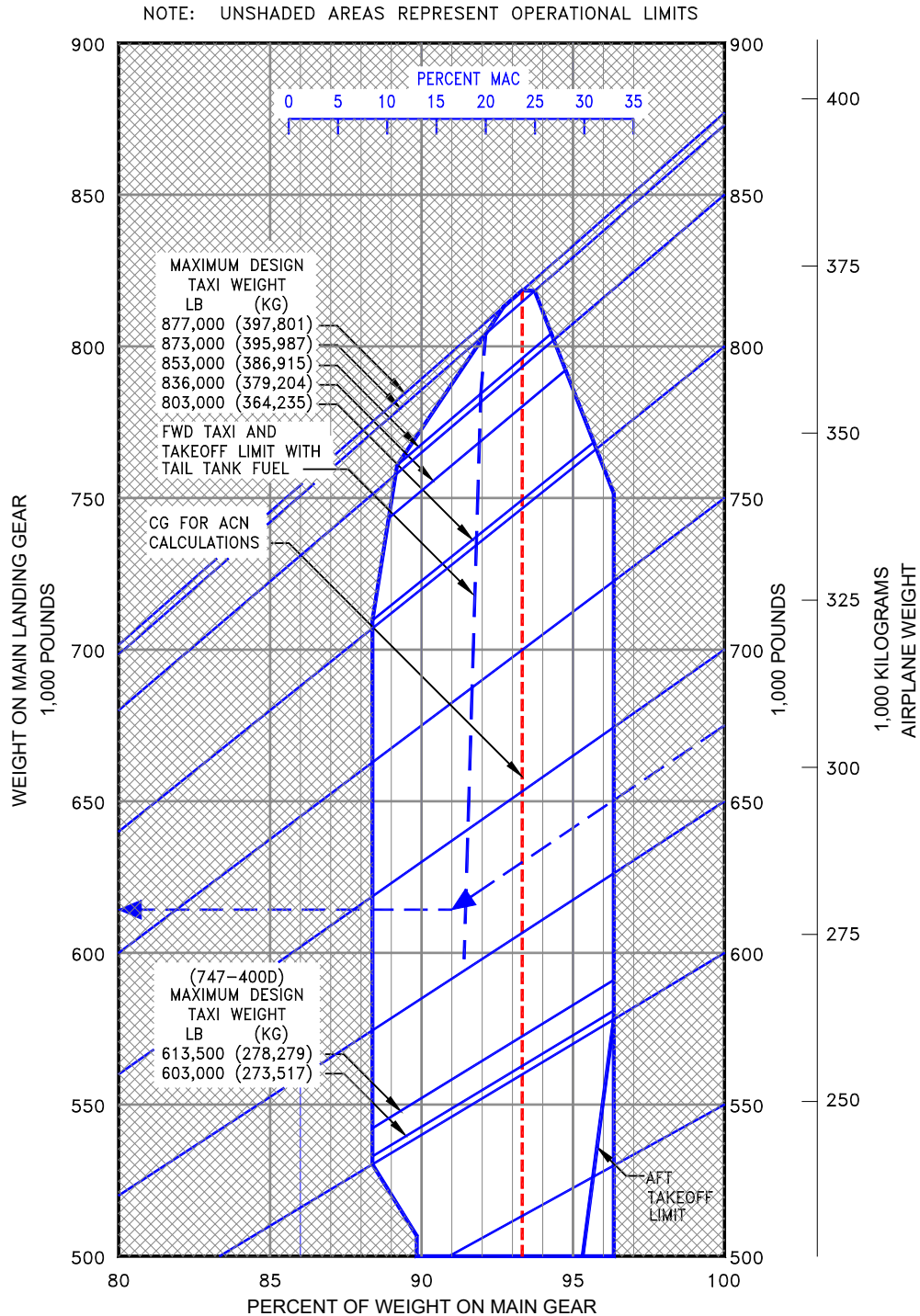

D6-58326-1

REV E

September 2023

7-8

7.4.2 Landing Gear Loading on Pavement: Model 747-400 Freighter

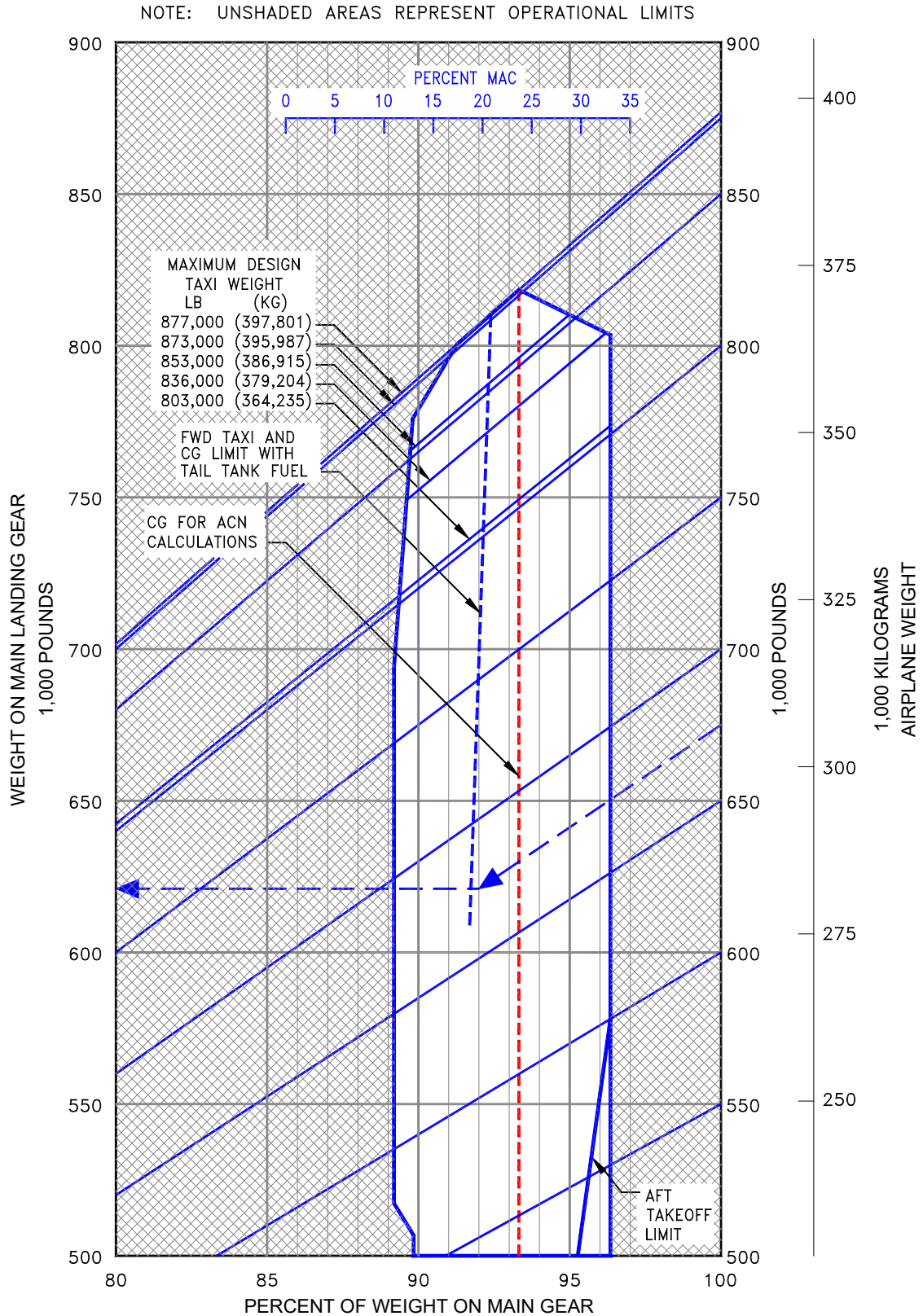

D6-58326-1

7.4.3 Landing Gear Loading On Pavement: Model 747-400ER

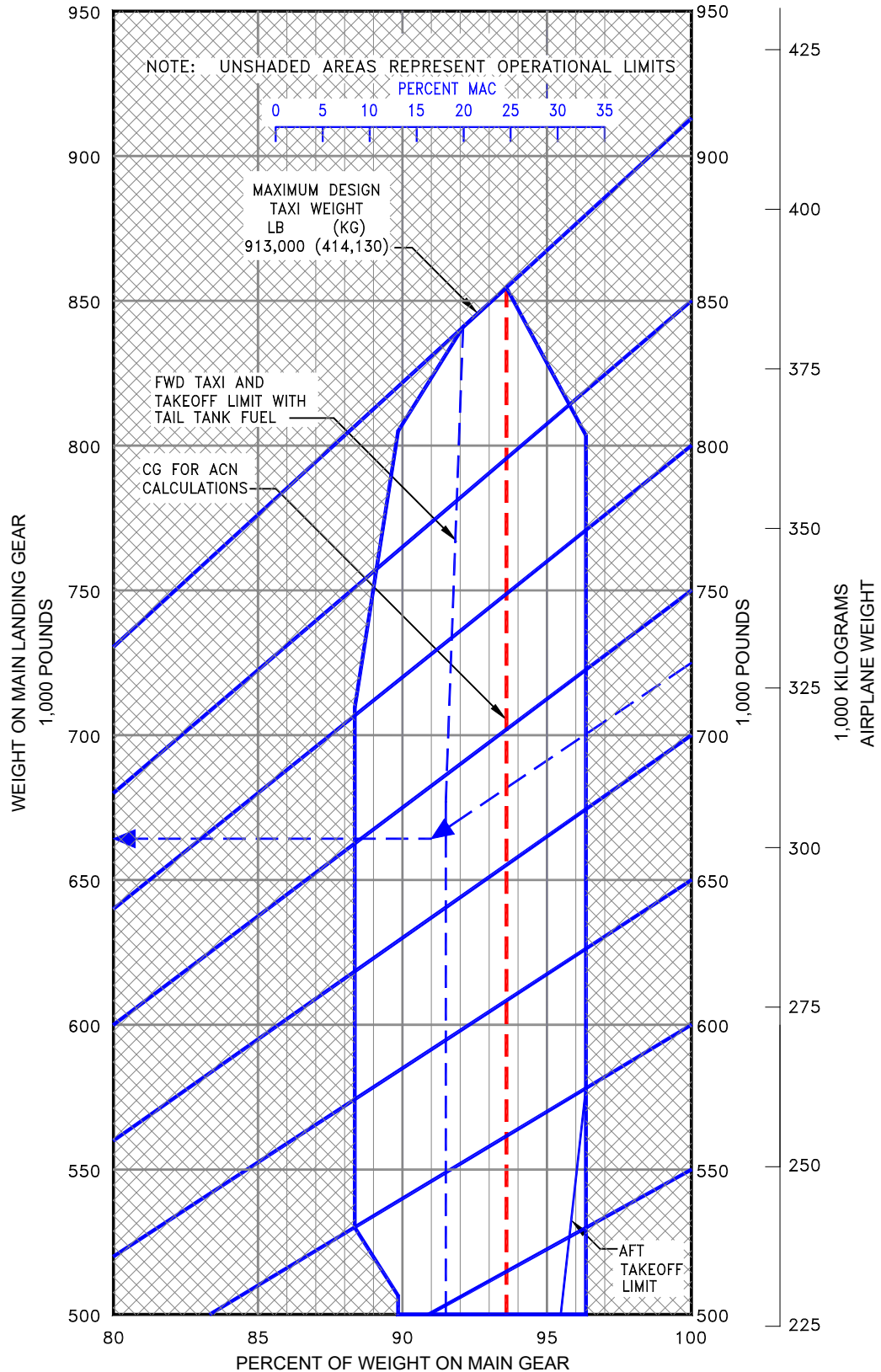

D6-58326-1

7.4.4 Landing Gear Loading On Pavement: Model 747-400ER Freighter

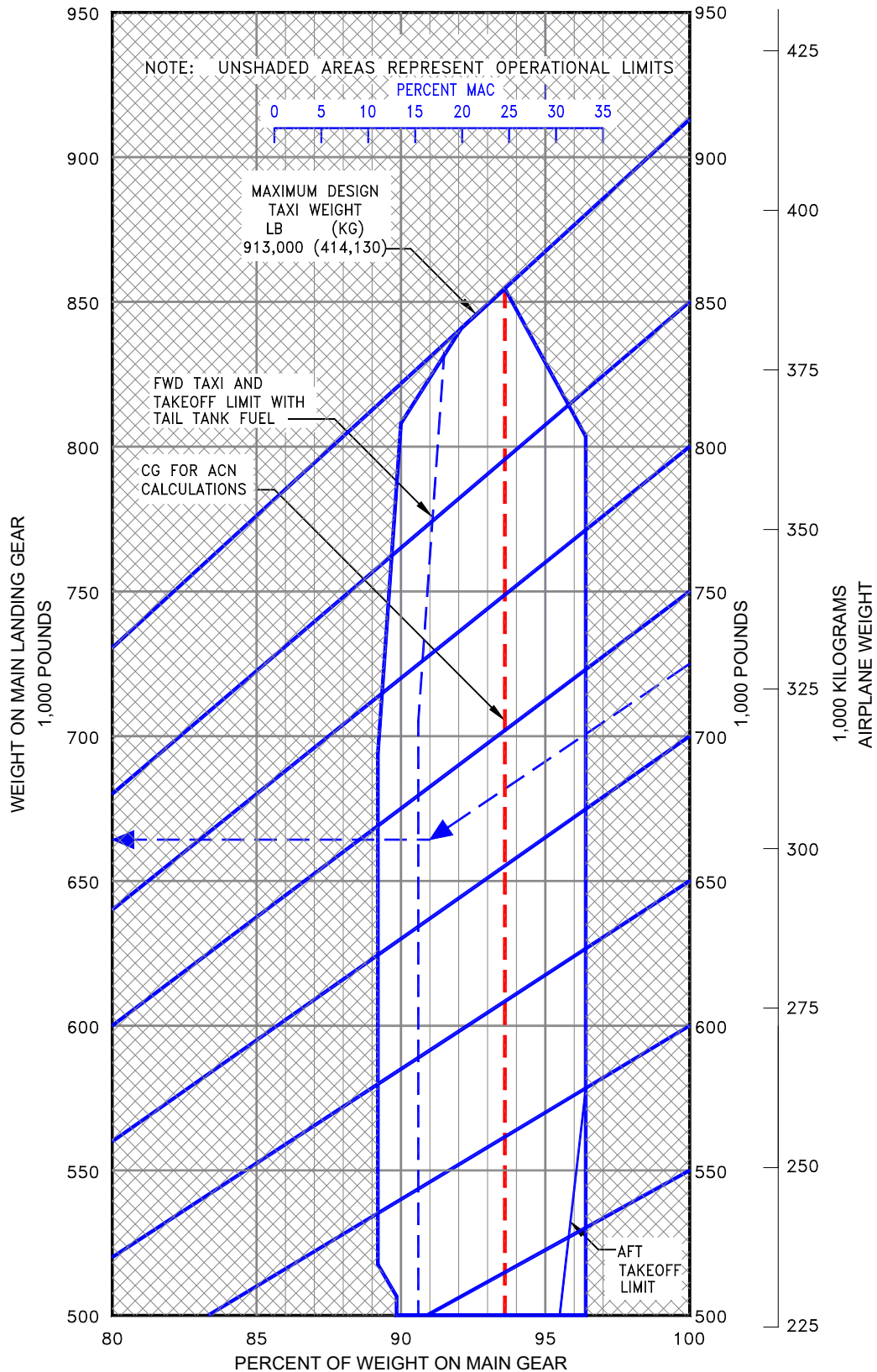

D6-58326-1

7.5 FLEXIBLE PAVEMENT REQUIREMENTS - U.S. ARMY CORPS OF ENGINEERS METHOD (S-77-1) AND FAA DESIGN METHOD

The following flexible-pavement design chart presents the data of six incremental main-gear loads at the minimum tire pressure required at the maximum design taxi weight.

In the example shown in Section 7.5.1, for a CBR of 35.5 and an annual departure level of 6,000, the required flexible pavement thickness for a 747-400 airplane with a main gear loading of 818,400 pounds is 13.1 inches. In Section 7.5.2, for the same CBR and departure levels, the required flexible pavement thickness for a 747-400ER airplane with a main gear loading of 854,408 pounds is 14.2 inches.

The line showing 10,000 coverages is used for ACN calculations (see Section 7.10).

The FAA design method uses a similar procedure using total airplane weight instead of weight on the main landing gears. The equivalent main gear loads for a given airplane weight could be calculated from Section 7.4.

7.5.1 Flexible Pavement Requirements - U.S. Army Corps of Engineers Design Method (S-77-1) and FAA Design Method: Model 747-400, -400 Combi, -400 Domestic, -400 Freighter

NOTE: TIRES - H40 x 14.5-19 24PR. 26PR

CALIFORNIA BEARING RATIO, CBR

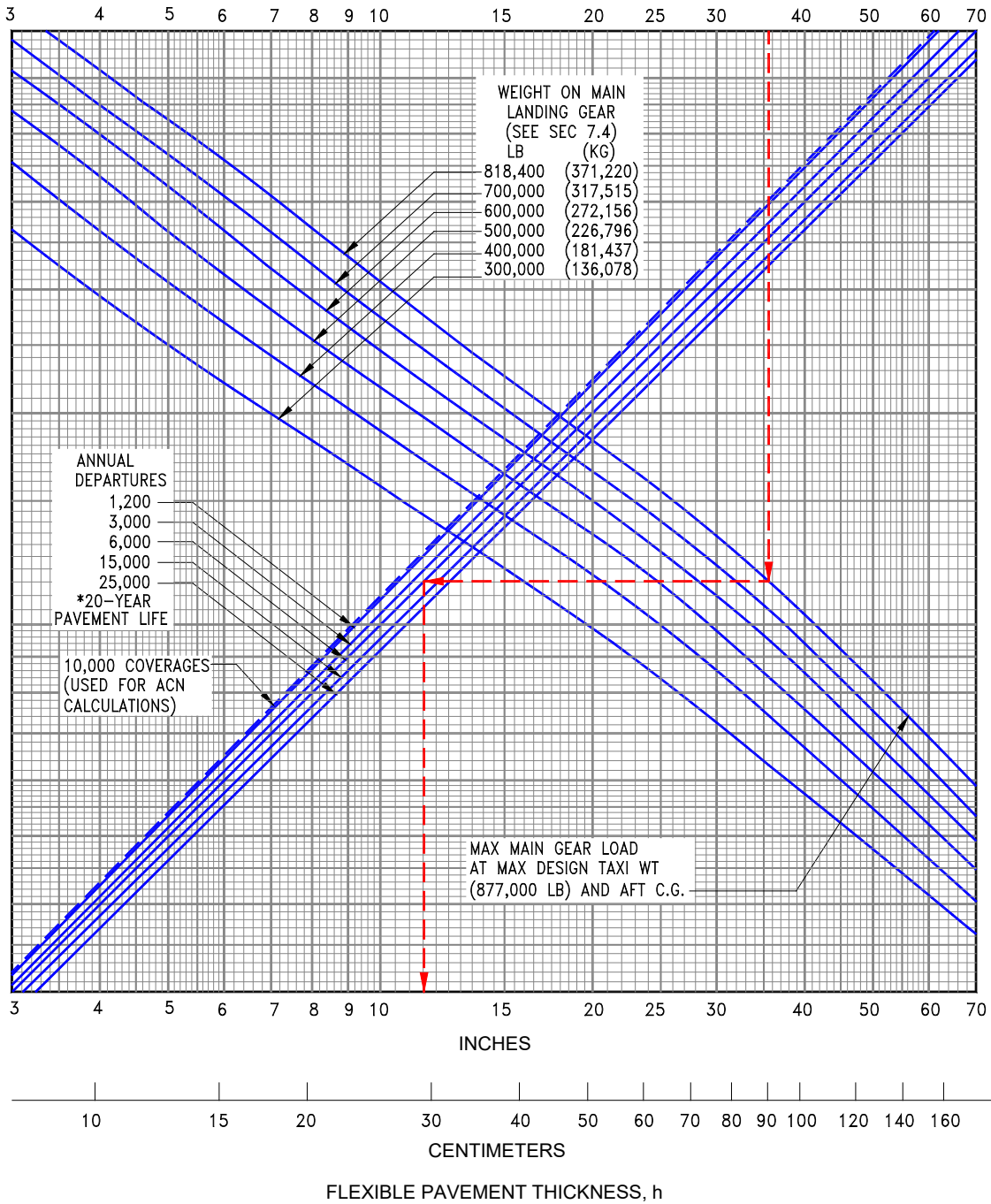

D6-58326-1

7.5.2 Flexible Pavement Requirements - U.S. Army Corps of Engineers Design Method (S-77-1): Model 747-400ER, -400ER Freighter

NOTE: TIRES - 50 x 20 R22, 34PR AT 230 PSI (16.17 KG/CM SQ)

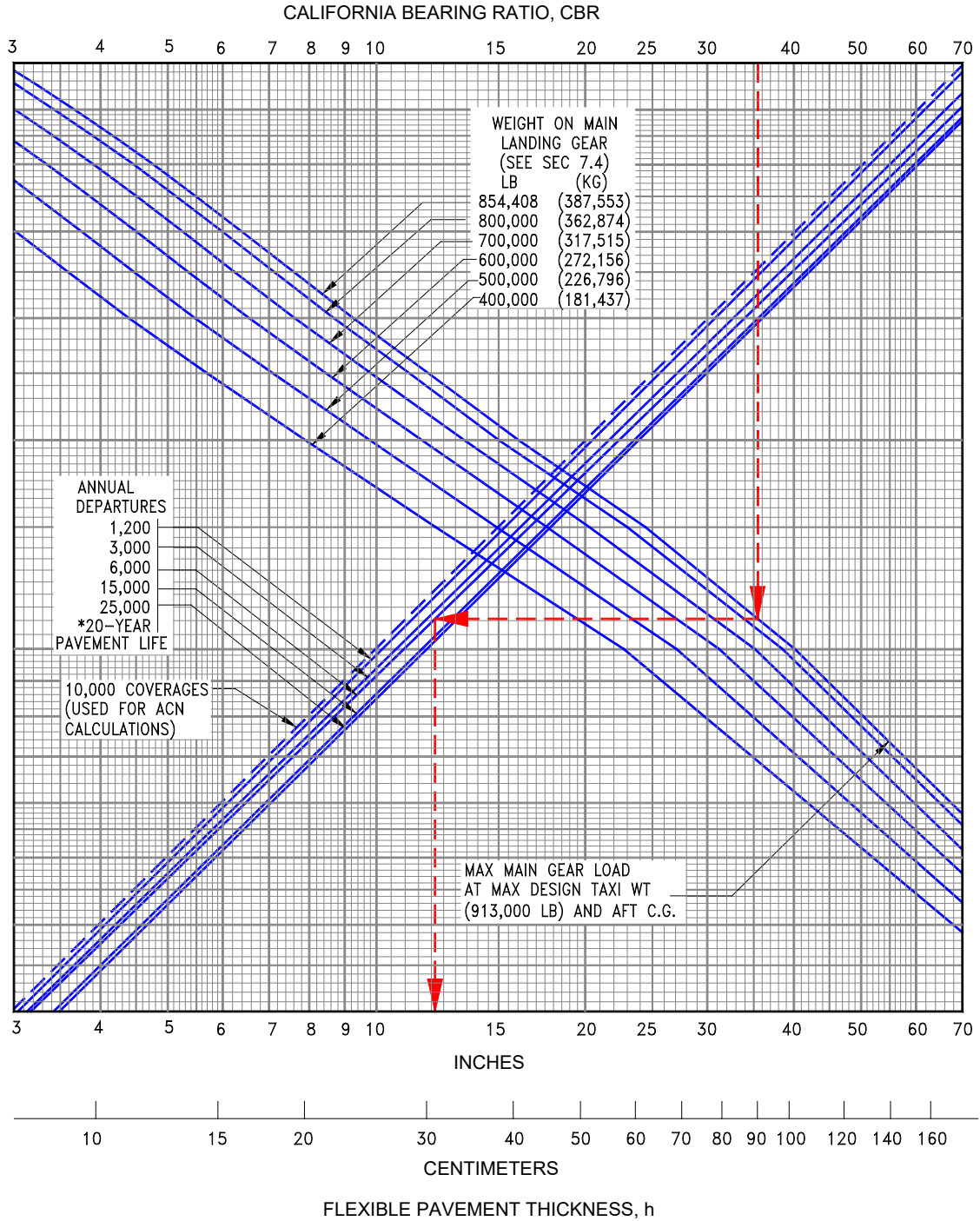

D6-58326-1

REV E

September 2023

7-14

7.6 FLEXIBLE PAVEMENT REQUIREMENTS - LCN METHOD

To determine the airplane weight that can be accommodated on a particular flexible pavement, both the Load Classification Number (LCN) of the pavement and the thickness must be known.

In the example shown in Section 7.6.1, flexible pavement thickness is shown at 21 inches with an LCN of 63. For these conditions, the apparent maximum allowable weight permissible on the main landing gear is 500,000 pounds for a 747-400 airplane with 200-psi main gear tires. In Section 7.6.2, for a flexible pavement thickness of 30 inches with an LCN of 95, the apparent maximum allowable weight permissible on the main landing gear is 600,000 pounds for a 747-400ER airplane with 230-psi main gear tires

Note: If the resultant aircraft LCN is not more than 10% above the published pavement LCN, the bearing strength of the pavement can be considered sufficient for unlimited use by the airplane. The figure 10% has been chosen as representing the lowest degree of variation in LCN that is significant (reference: ICAO Aerodrome Design Manual, Part 3, "Pavements," First Edition dated 1977.)

7.6.1 Flexible Pavement Requirements - LCN Method: Model 747-400, -400 Combi, -400 Domestic, -400 Freighter

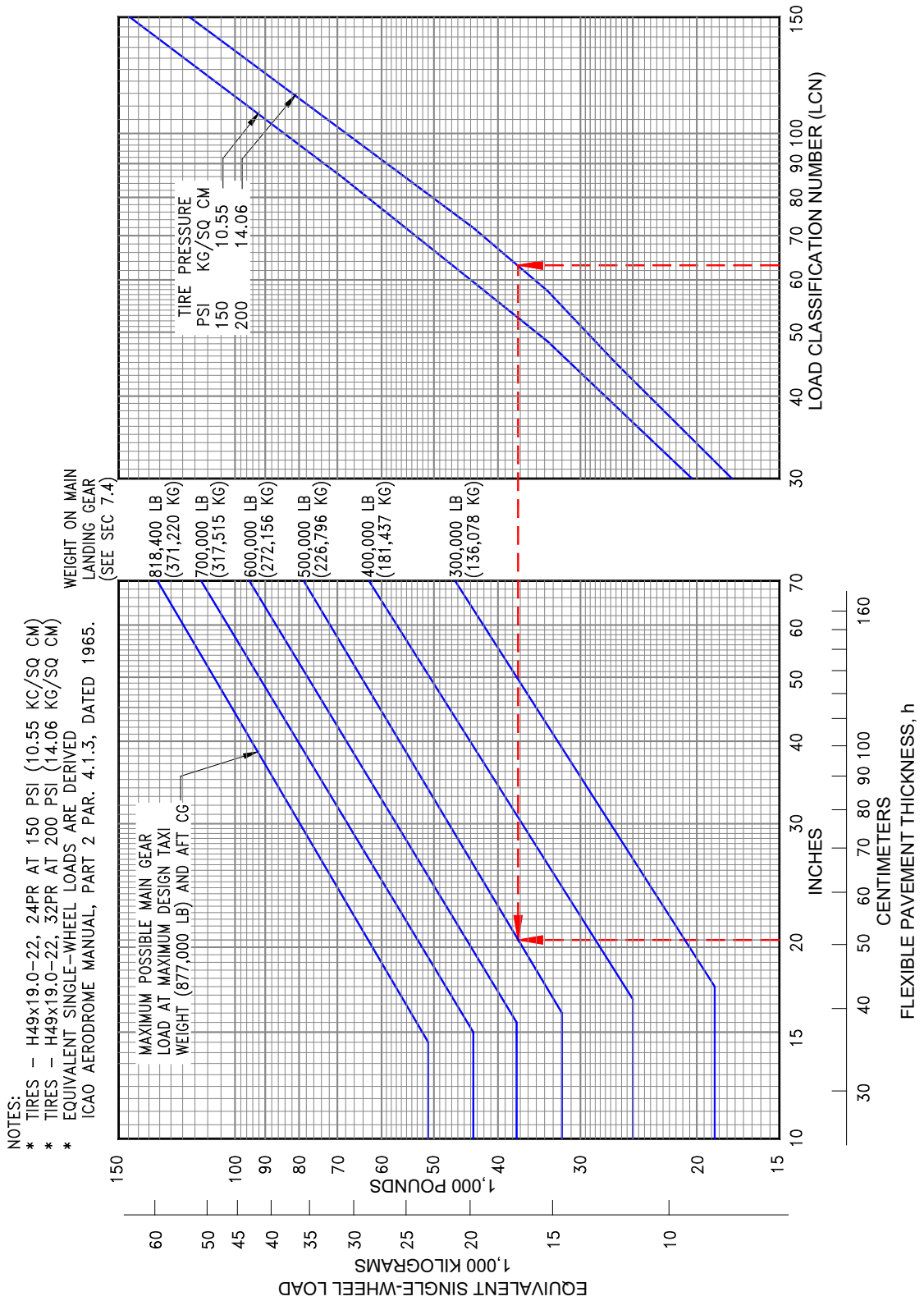

D6-58326-1

7.6.2 Flexible Pavement Requirements - LCN METHOD: Model 747-400ER, -400ER Freighter

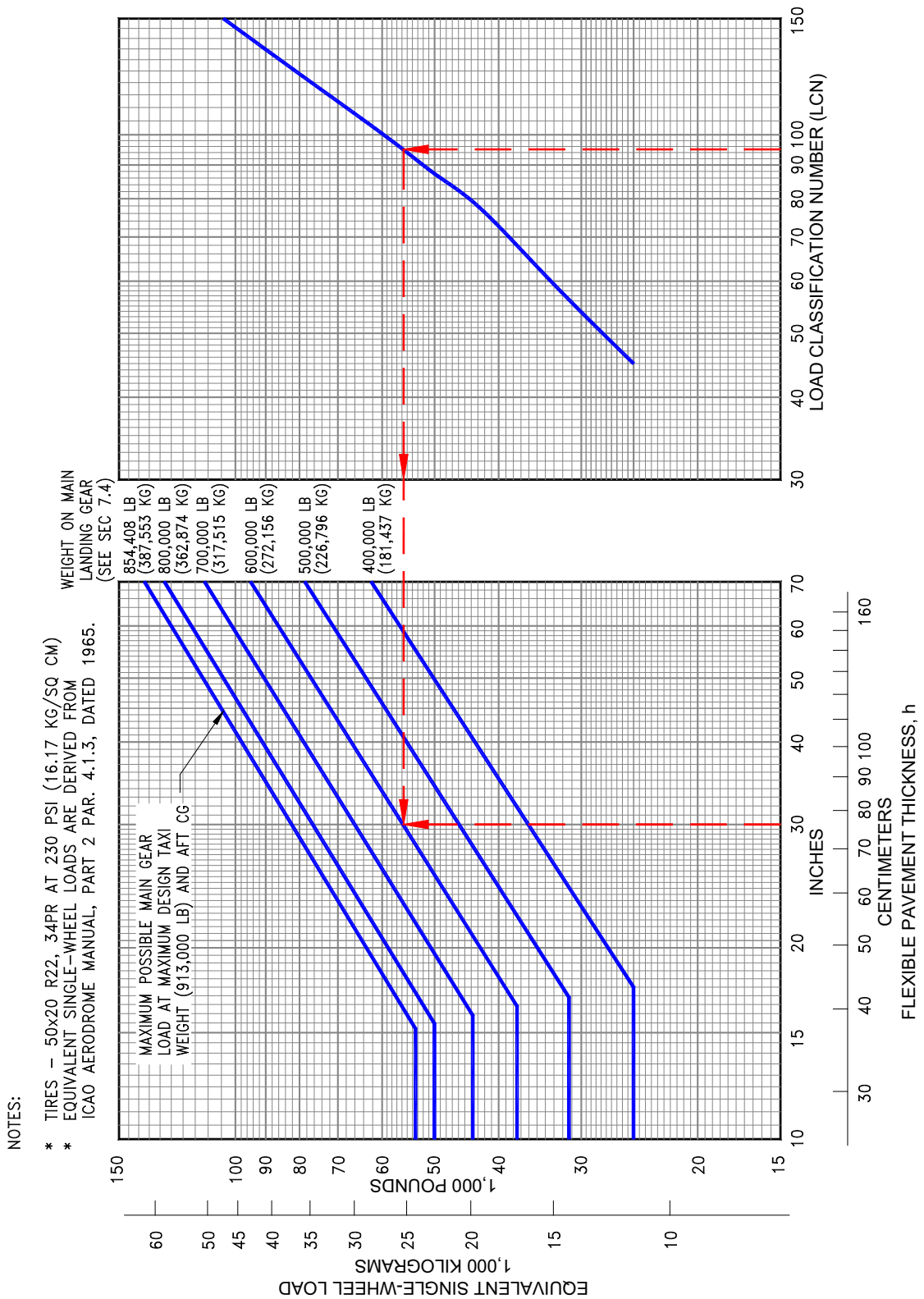

D6-58326-1

7.7 RIGID PAVEMENT REQUIREMENTS - PORTLAND CEMENT ASSOCIATION DESIGN METHOD

The Portland Cement Association method of calculating rigid pavement requirements is based on the computerized version of "Design of Concrete Airport Pavement" (Portland Cement Association, 1965) as described in XP6705-2, "Computer Program for Airport Pavement Design" by Robert G. Packard, Portland Cement Association, 1968.

The rigid pavement design charts in Section 7.7.1 and Section 7.7.2 present data for six incremental main gear loads at the minimum tire pressure required at the maximum design taxi weight.

In the example shown in Section 7.7.1, for an allowable working stress of 550 psi, a main gear load on a 747-400 airplane of 700,000 pounds, and a subgrade strength (k) of 300, the required rigid pavement thickness is 9.6 inches. In Section 7.7.2, for an allowable working stress of 550 psi, a main gear load on a 747-400ER airplane of 800,000 pounds, and a subgrade strength (k) of 300, the required rigid pavement thickness is 10.8 inches.

7.7.1 Rigid Pavement Requirements - Portland Cement Association Design Method: Model 747-400, -400 Combi, -400 Domestic, -400 Freighter

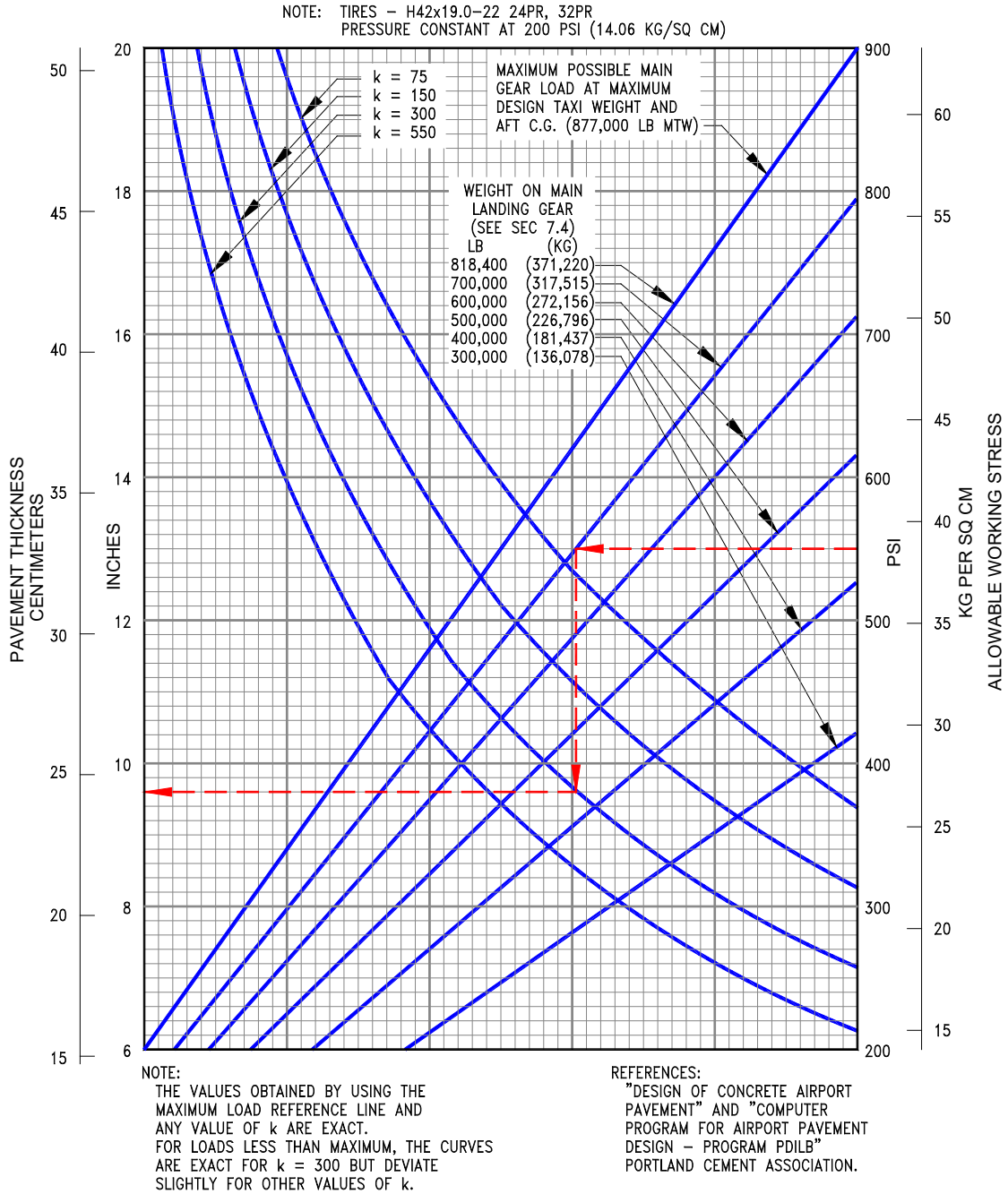

D6-58326-1

REV E

September 2023

7-19

7.7.2 Rigid Pavement Requirements - Portland Cement Association Design Method: Model 747-400ER, -400ER Freighter

NOTE: TIRES - 50x20 R22, 34PR AT 230 PSI (16.17 KG/CM SQ)

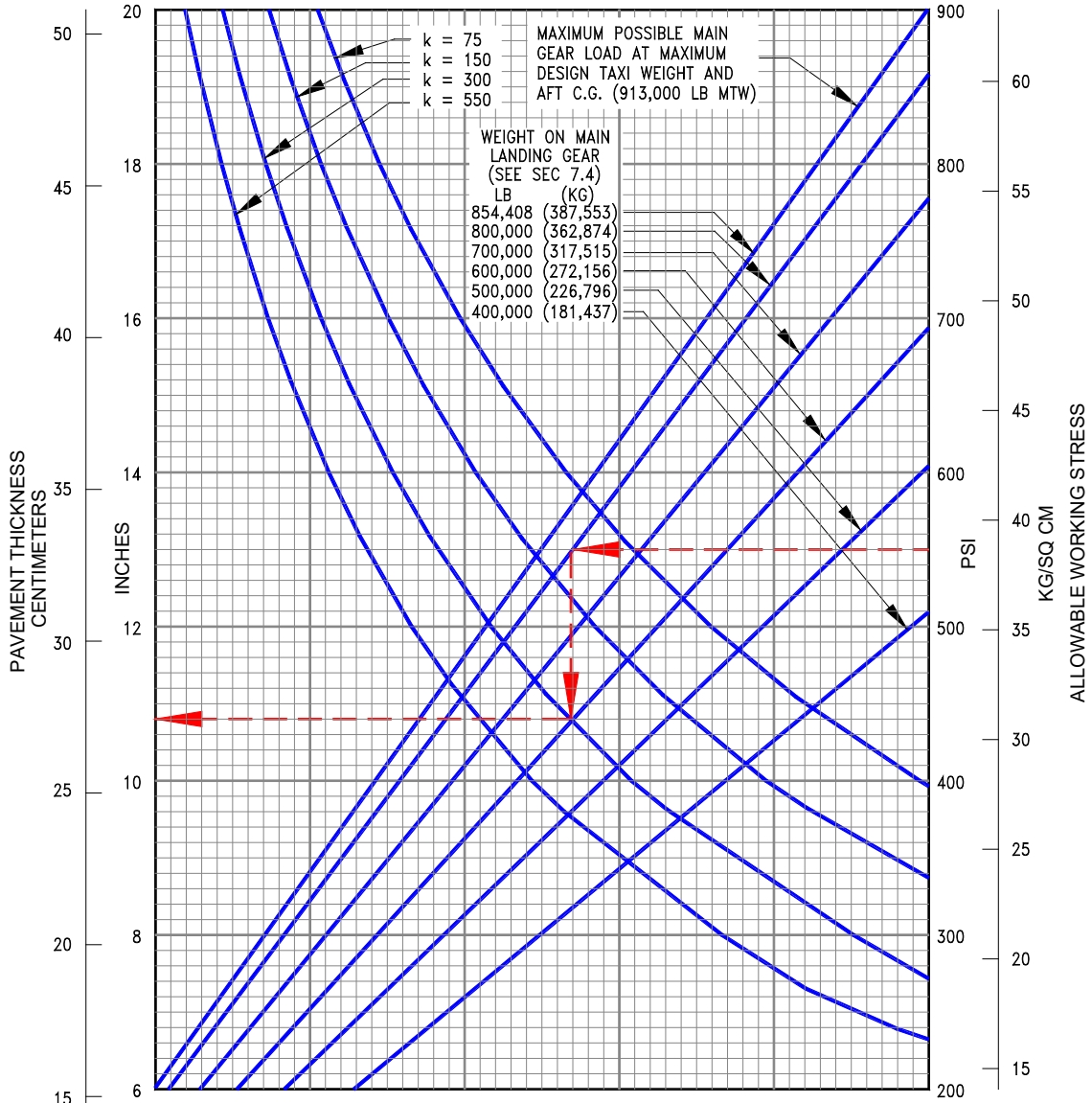

NOTE:
 THE VALUES OBTAINED BY USING THE MAXIMUM LOAD REFERENCE LINE AND ANY VALUE OF k ARE EXACT.
 FOR LOADS LESS THAN MAXIMUM, THE CURVES ARE EXACT FOR k = 300 BUT DEVIATE SLIGHTLY FOR OTHER VALUES OF k.

REFERENCES:
 "DESIGN OF CONCRETE AIRPORT PAVEMENT" AND "COMPUTER PROGRAM FOR AIRPORT PAVEMENT DESIGN - PROGRAM PDILB"
 PORTLAND CEMENT ASSOCIATION.

D6-58326-1

7.8 RIGID PAVEMENT REQUIREMENTS - LCN CONVERSION

To determine the airplane weight that can be accommodated on a particular rigid pavement, both the LCN of the pavement and the radius of relative stiffness (ℓ) of the pavement must be known.

In the example shown in Section 7.8.2, for a rigid pavement with a radius of relative stiffness of 48 with an LCN of 58, the apparent maximum allowable weight permissible on the main landing gear is 400,000 pounds for a 747-400 airplane with 200-psi main tires. In Section 7.8.3, for a rigid pavement with a radius of relative stiffness of 47 with an LCN of 91, the apparent maximum allowable weight permissible on the main landing gear is 600,000 pounds for a 747-400ER airplane with 230-psi main tires.

Note: If the resultant aircraft LCN is not more than 10% above the published pavement LCN, the bearing strength of the pavement can be considered sufficient for unlimited use by the airplane. The figure 10% has been chosen as representing the lowest degree of variation in LCN that is significant (reference: ICAO Aerodrome Design Manual, Part 3, "Pavements," First Edition dated 1977).

7.8.1 Radius of Relative Stiffness (Reference: Portland Cement Association)

RADIUS OF RELATIVE STIFFNESS (ℓ)

VALUES IN INCHES

$$\ell = \sqrt[4]{\frac{Ed^3}{12(1-\mu^2)k}} = 24.1652 \sqrt[4]{\frac{d^3}{k}}$$

WHERE: E = YOUNG'S MODULUS OF ELASTICITY = 4×10^6 psi

k = SUBGRADE MODULUS, LB PER CU IN

d = RIGID PAVEMENT THICKNESS, IN

μ = POISSON'S RATIO = 0.15

d	k = 75	k = 100	k = 150	k = 200	k = 250	k = 300	k = 350	k = 400	k = 500	k = 550
6.0	31.48	29.29	26.47	24.63	23.30	22.26	21.42	20.71	19.59	19.13
6.5	33.42	31.10	28.11	26.16	24.74	23.63	22.74	21.99	20.80	20.31
7.0	35.33	32.88	29.71	27.65	26.15	24.99	24.04	23.25	21.99	21.47
7.5	37.21	34.63	31.29	29.12	27.54	26.31	25.32	24.49	23.16	22.61
8.0	39.06	36.35	32.84	30.56	28.91	27.62	26.57	25.70	24.31	23.73
8.5	40.87	38.04	34.37	31.99	30.25	28.90	27.81	26.90	25.44	24.84
9.0	42.66	39.70	35.88	33.39	31.57	30.17	29.03	28.07	26.55	25.93
9.5	44.43	41.35	37.36	34.77	32.88	31.42	30.23	29.24	27.65	27.00
10.0	46.17	42.97	38.83	36.13	34.17	32.65	31.41	30.38	28.73	28.06
10.5	47.89	44.57	40.27	37.48	35.44	33.87	32.58	31.52	29.81	29.10
11.0	49.59	46.15	41.70	38.81	36.70	35.07	33.74	32.63	30.86	30.14

d	k = 75	k = 100	k = 150	k = 200	k = 250	k = 300	k = 350	k = 400	k = 500	k = 550
11.5	51.27	47.72	43.12	40.12	37.95	36.26	34.89	33.74	31.91	31.16
12.0	52.94	49.26	44.51	41.43	39.18	37.43	36.02	34.83	32.94	32.17
12.5	54.58	50.80	45.90	42.71	40.40	38.60	37.14	35.92	33.97	33.17
13.0	56.21	52.31	47.27	43.99	41.60	39.75	38.25	36.99	34.98	34.16
13.5	57.83	53.81	48.63	45.25	42.80	40.89	39.34	38.05	35.99	35.14
14.0	59.43	55.30	49.97	46.50	43.98	42.02	40.43	39.10	36.98	36.11
14.5	61.01	56.78	51.30	47.74	45.15	43.14	41.51	40.15	37.97	37.07
15.0	62.58	58.24	52.62	48.97	46.32	44.25	42.58	41.18	38.95	38.03
15.5	64.14	59.69	53.93	50.19	47.47	45.35	43.64	42.21	39.92	38.98
16.0	65.69	61.13	55.23	51.40	48.61	46.45	44.69	43.22	40.88	39.92
16.5	67.22	62.55	56.52	52.60	49.75	47.53	45.73	44.23	41.83	40.85
17.0	68.74	63.97	57.80	53.79	50.87	48.61	46.77	45.23	42.78	41.77
17.5	70.25	65.38	59.07	54.97	51.99	49.68	47.80	46.23	43.72	42.69
18.0	71.75	66.77	60.34	56.15	53.10	50.74	48.82	47.22	44.65	43.60
19.0	74.72	69.54	62.83	58.47	55.30	52.84	50.84	49.17	46.50	45.41
20.0	77.65	72.26	65.30	60.77	57.47	54.91	52.83	51.10	48.33	47.19
21.0	80.55	74.96	67.73	63.03	59.61	56.95	54.80	53.00	50.13	48.95
22.0	83.41	77.62	70.14	65.27	61.73	58.98	56.75	54.88	51.91	50.68
23.0	86.23	80.25	72.51	67.48	63.82	60.98	58.67	56.74	53.67	52.40
24.0	89.03	82.85	74.86	69.67	65.89	62.95	60.57	58.58	55.41	54.10
25.0	91.80	85.43	77.19	71.84	67.94	64.91	62.46	60.41	57.13	55.78

7.8.2 Rigid Pavement Requirements - LCN Conversion: Model 747-400, -400 Combi, -400 Domestic, -400 Freighter

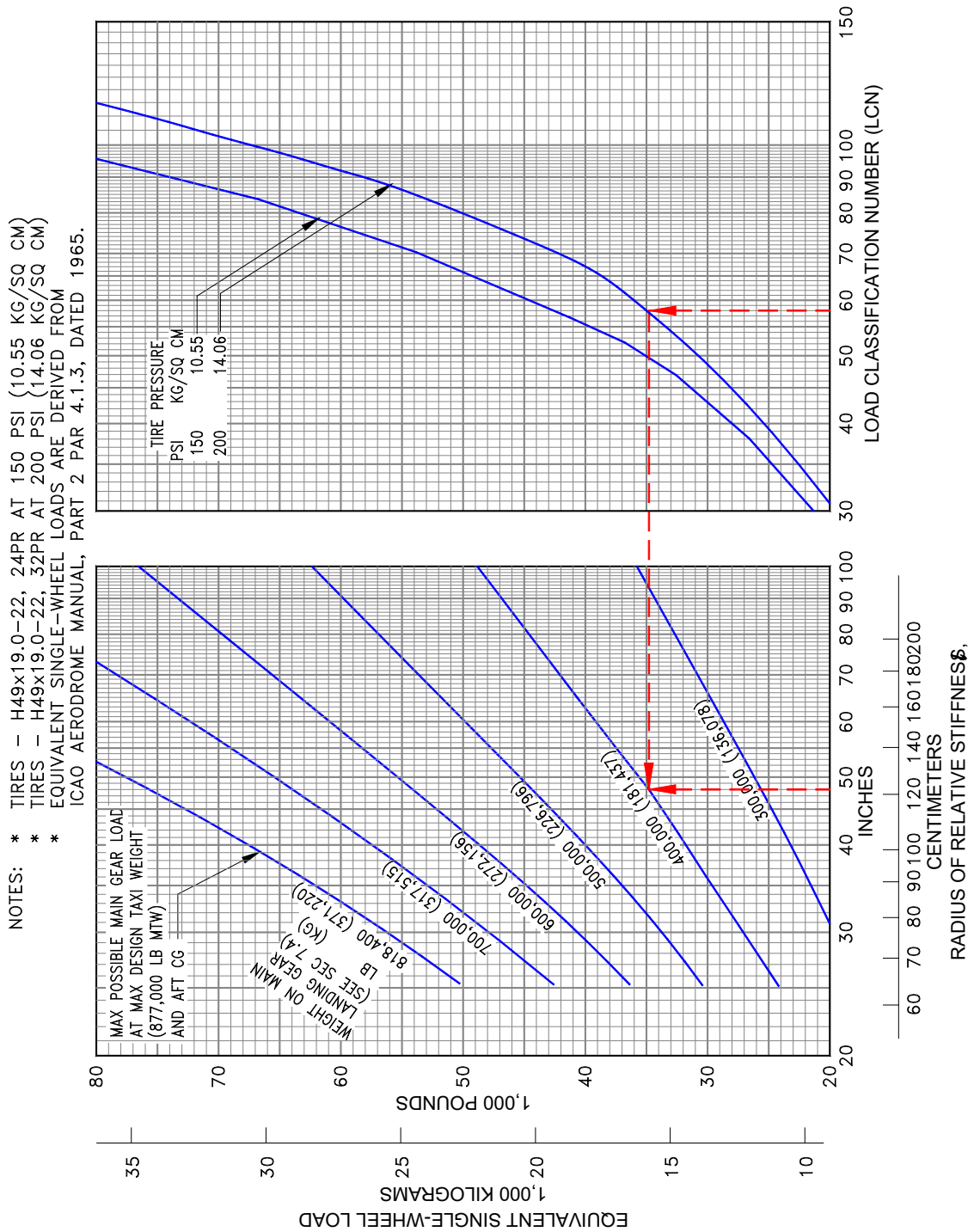

D6-58326-1

7.8.3 Rigid Pavement Requirements - LCN Conversion: Model 747-400ER, -400ER Freighter

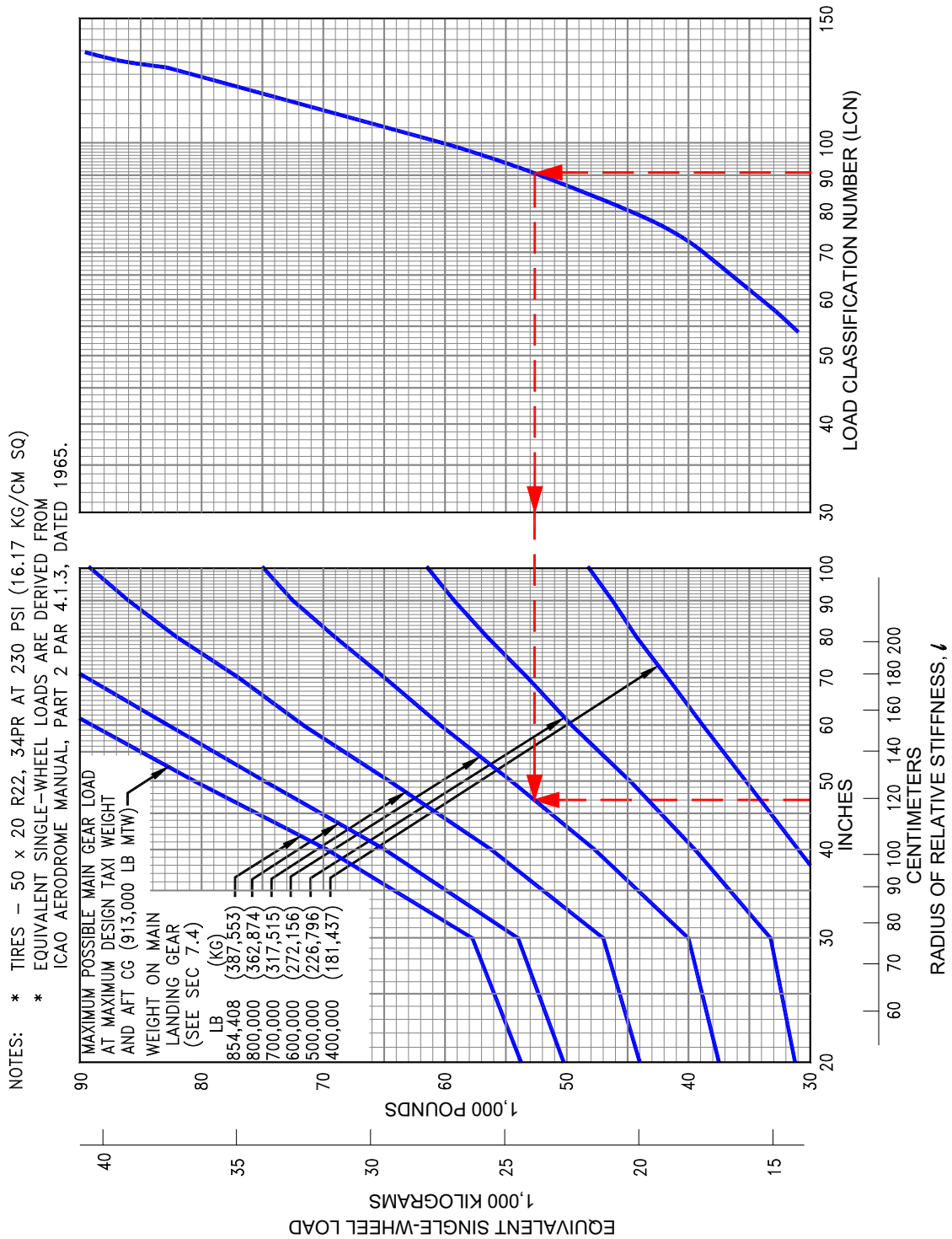

D6-58326-1

7.9 RIGID PAVEMENT REQUIREMENTS - FAA DESIGN METHOD

The rigid pavement design charts shown in Section 7.9.1 and Section 7.9.2 present data on six incremental main gear loads at the minimum tire pressure required at the maximum design taxi weight.

In the example shown in Section 7.9.1, for a pavement flexure strength of 725 psi, a subgrade strength of $k = 300$, and an annual departure level of 6,000, the required rigid pavement thickness for a 747-400 airplane with a main gear load of 600,000 pounds is 10.4 inches. In Section 7.9.2, for a pavement flexure strength of 700 psi, a subgrade strength of $k = 300$, and an annual departure level of 3,000, the required rigid pavement thickness for a 747-40ER airplane with a main gear load of 600,000 pounds is 10.4 inches.

7.9.1 Rigid Pavement Requirements - FAA Design Method: Model 747-400, -400 Combi, -400 Domestic, -400 Freighter

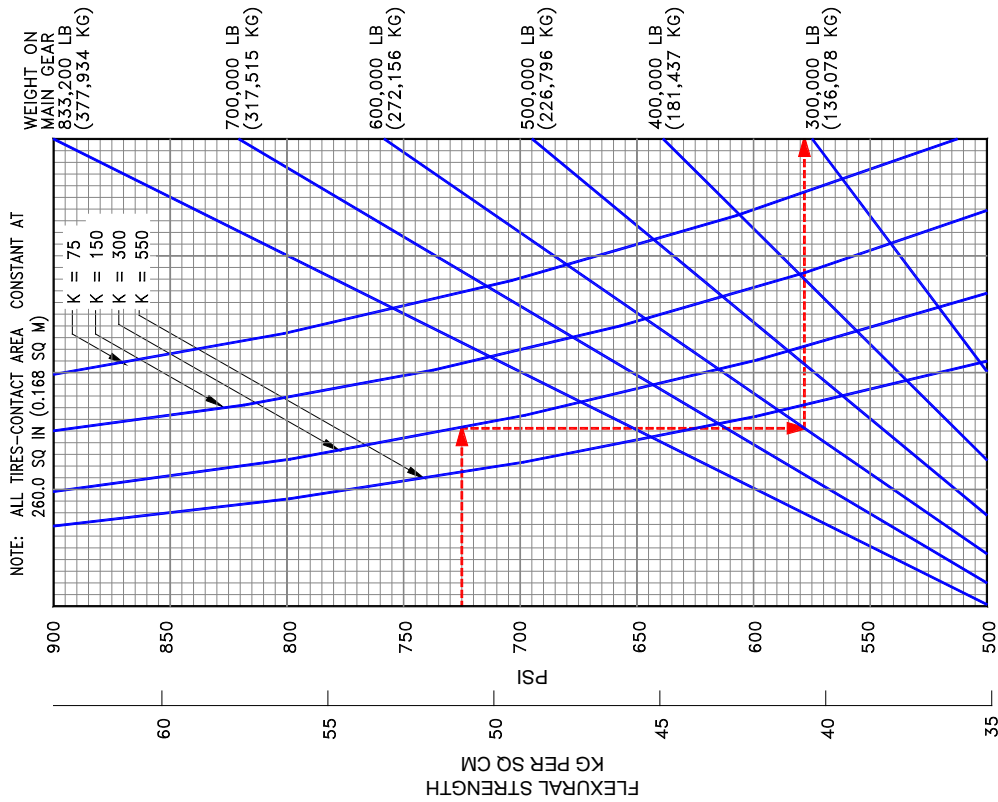
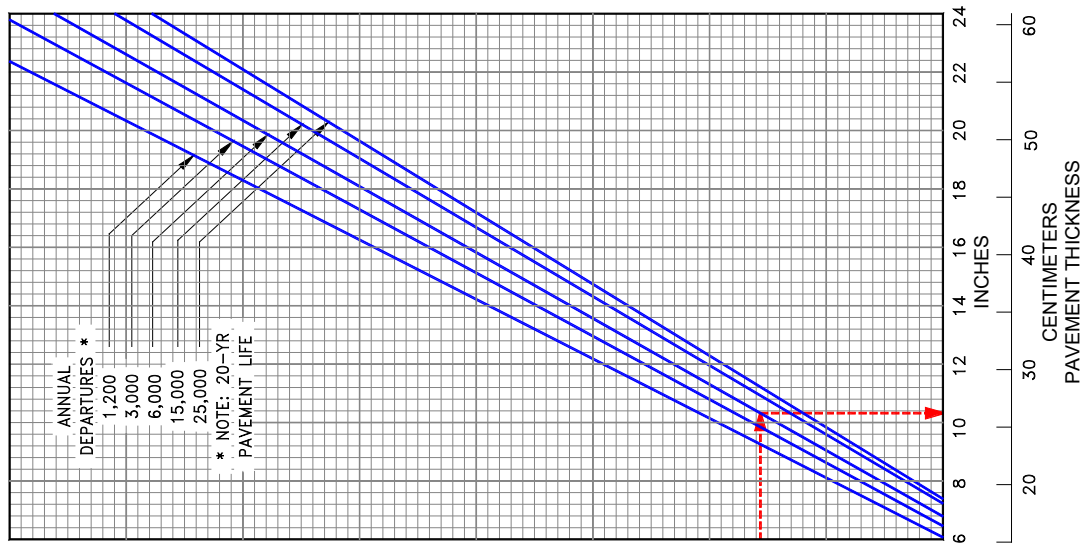

D6-58326-1

7.9.2 Pavement Requirements - FAA Design Method: Model 747-400ER, -400ER Freighter

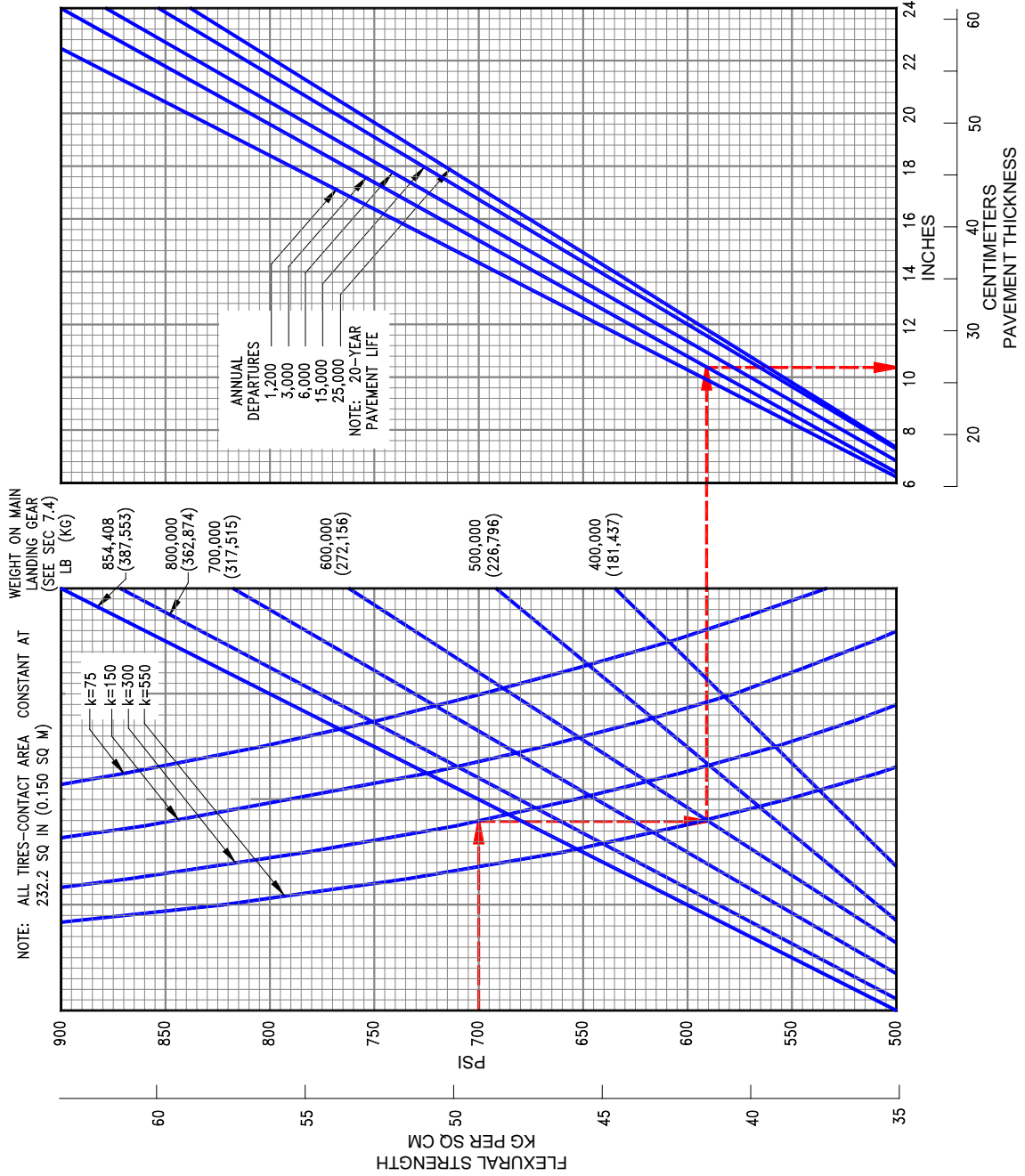

D6-58326-1

7.10 ACN/PCN REPORTING SYSTEM - FLEXIBLE AND RIGID PAVEMENTS

To determine the ACN of an aircraft on flexible or rigid pavement, both the aircraft gross weight and the subgrade strength category must be known. In the example in Section 7.10.1, for a 747-400 aircraft with a gross weight of 675,000 pounds and medium subgrade strength, the flexible pavement ACN is 41.5. In Section 7.10.3, for the same aircraft and subgrade strength, the rigid pavement ACN is 43.8. In Section 7.10.2, for a 747-400ER aircraft with a gross weight of 900,000 pounds and medium subgrade strength, the flexible pavement ACN is 62. In Section 7.10.4, for the same aircraft and subgrade strength, the rigid pavement ACN is 57.8.

- Notes:**
1. An aircraft with an ACN equal to or less than the reported PCN can operate on that pavement subject to any limitations on the tire pressure. (Ref: ICAO Annex 14 Aerodromes, First Edition, July 1990.)
 2. The ACN values on the Flexible Pavement charts were calculated using alpha factors proposed by the ICAO ACN Study Group.

The following table provides ACN data in tabular format similar to the one used by ICAO in the “Aerodrome Design Manual Part 3, Pavements.” If the ACN for an intermediate weight between taxi weight and minimum weight of the aircraft is required, Sections 7.10.1 through 7.10.4 should be consulted.

AIRCRAFT TYPE	MAXIMUM TAXI WEIGHT MINIMUM WEIGHT (1) LB (KG)	LOAD ON ONE MAIN GEAR LEG (%)	TIRE PRESSURE PSI (MPa)	ACN FOR RIGID PAVEMENT SUBGRADES – MN/m ³				ACN FOR FLEXIBLE PAVEMENT SUBGRADES – CBR			
				HIGH 550 (150)	MEDIUM 300 (80)	LOW 150 (40)	ULTRA LOW 75 (20)	HIGH 15	MEDIUM 10	LOW 6	ULTRA LOW 3
747-400, -400F	877,000(397,800)	23.33	200(1.38)	53	62	74	85	53	59	73	94
	395,000(179,200)			19	21	25	29	20	21	23	30
747-400ER, -400 ERF	913,000(414,130)	23.40	230 (1.58)	59	69	81	92	57	63	78	100
	362,400(164,400)			19	20	23	27	18	19	21	26

- (1) Minimum weight used solely as a baseline for ACN curve generation.

7.10.1 Aircraft Classification Number - Flexible Pavement: Model 747-400, -400 Combi, -400 Domestic, -400 Freighter

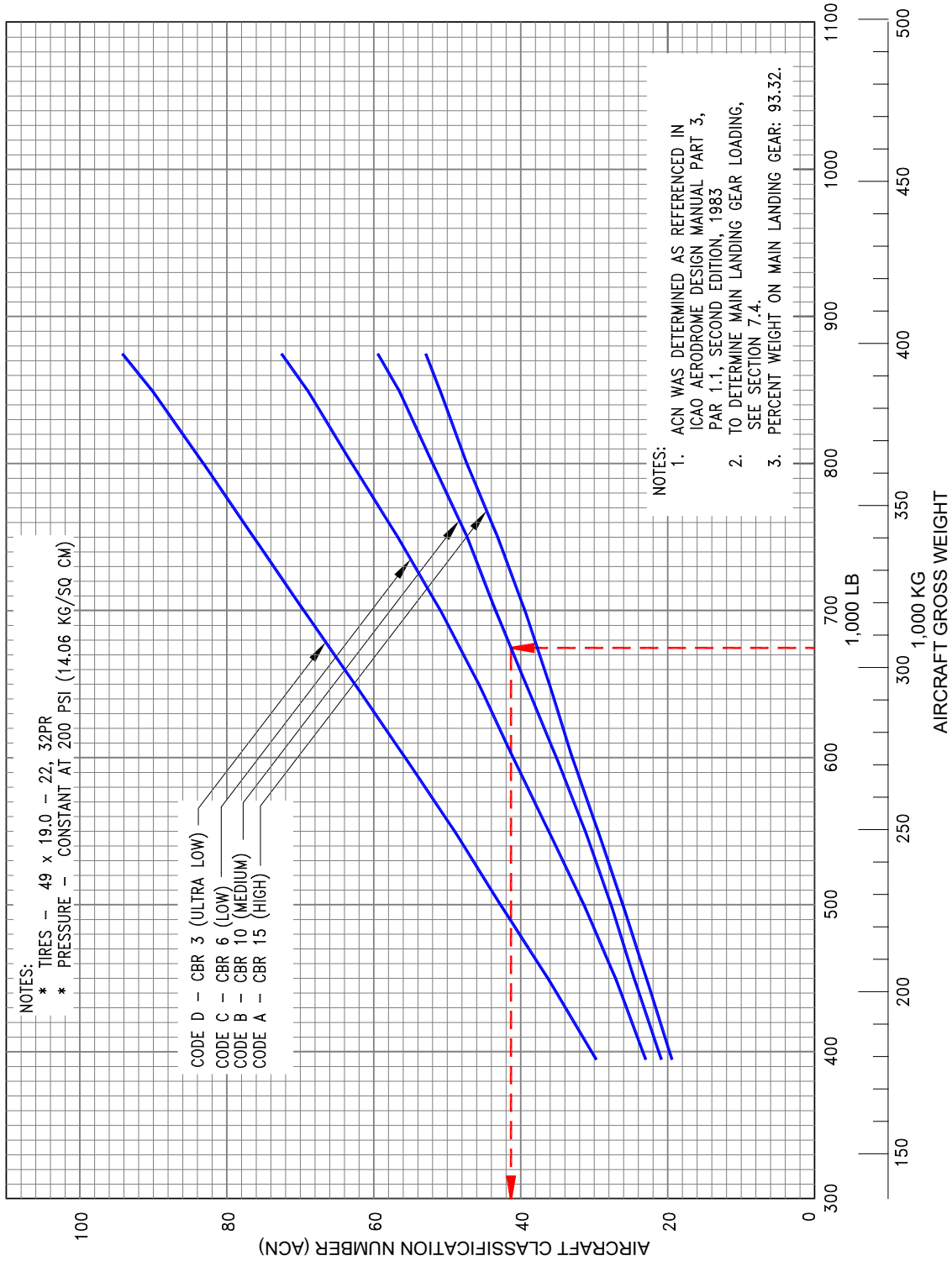

D6-58326-1

7.10.2 Aircraft Classification Number - Flexible Pavement: Model 747-400ER, -400er Freighter

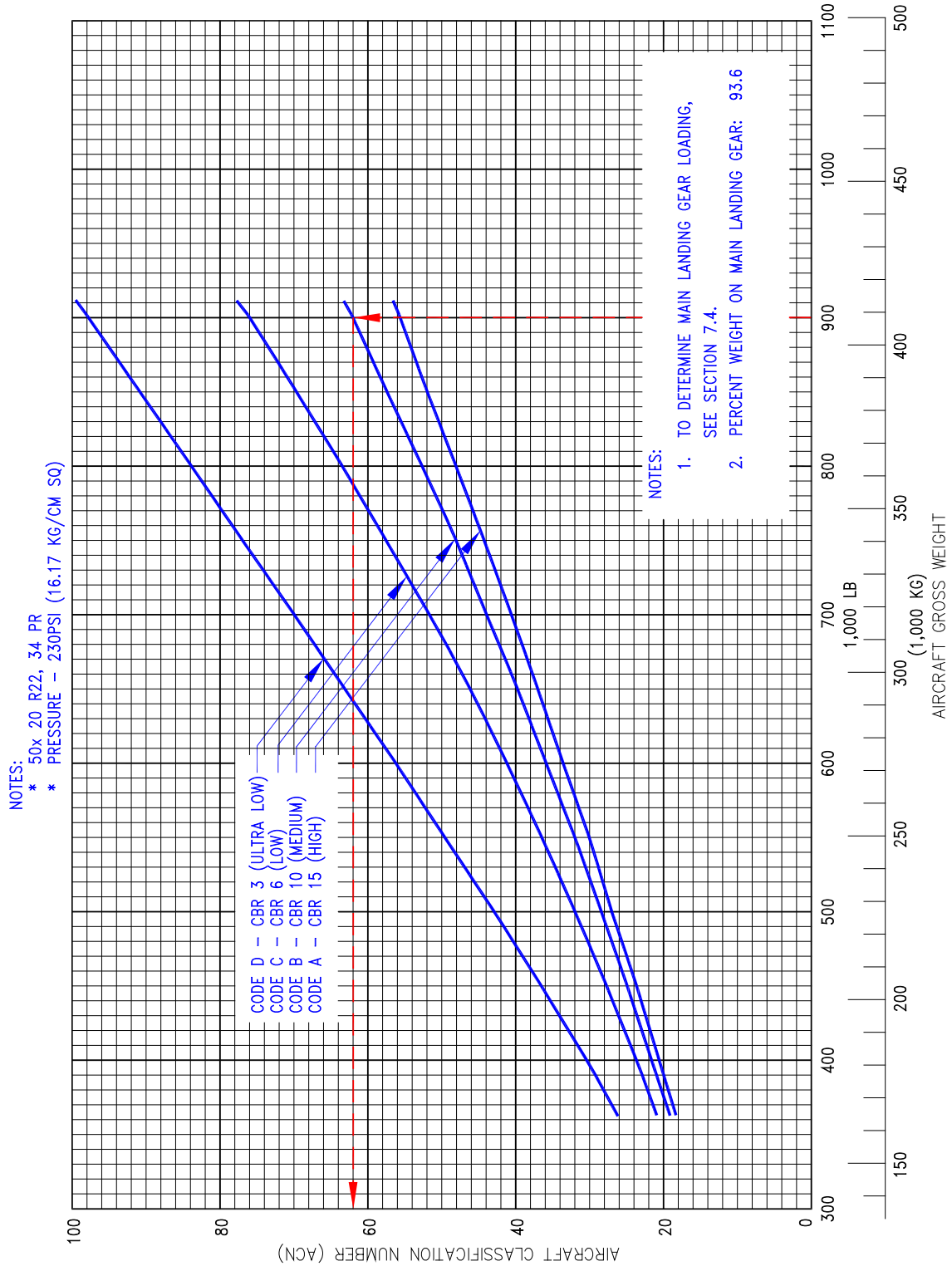

D6-58326-1

7.10.3 Aircraft Classification Number - Rigid Pavement: Model 747-400, -400 Combi, -400 Domestic, -400 Freighter

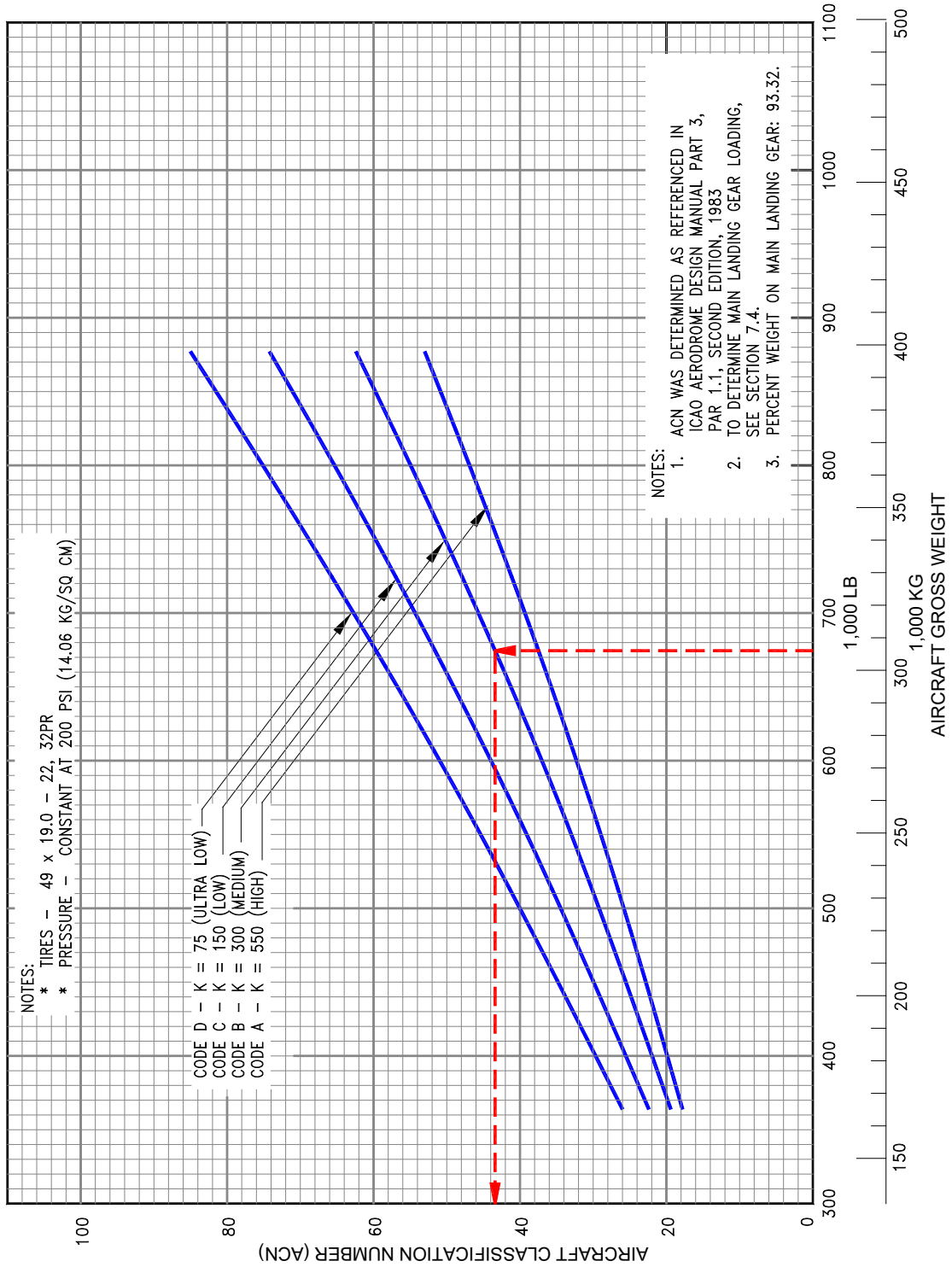

D6-58326-1

7.10.4 Aircraft Classification Number - Rigid Pavement: Model 747-400ER, -400ER Freighter

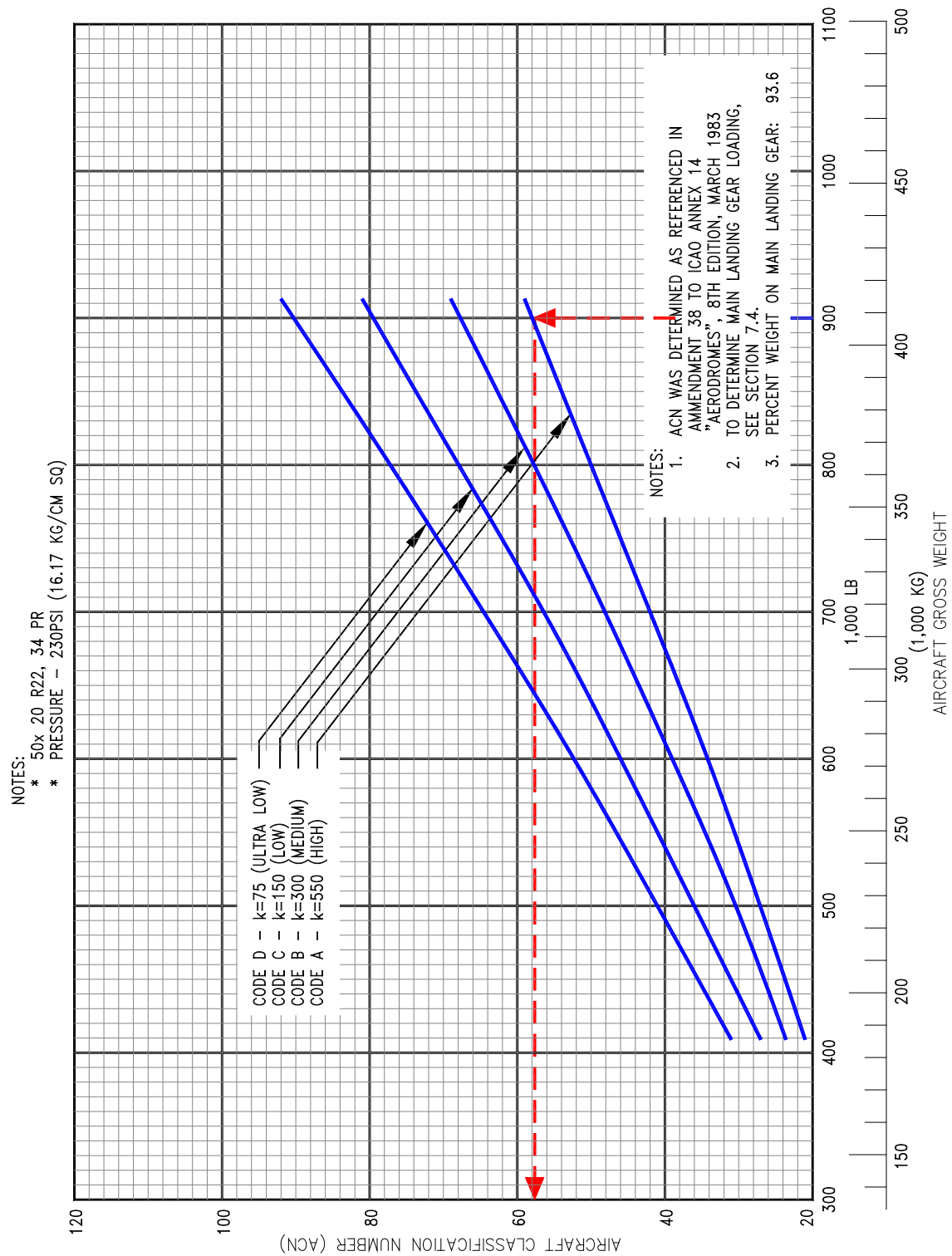

D6-58326-1

7.11 ACR/PCR REPORTING SYSTEM – FLEXIBLE AND RIGID PAVEMENTS

To determine the ACR of an aircraft on flexible or rigid pavement, the aircraft gross weight, the percent load on the main landing gear (%MLG), and the subgrade strength category must be known. The %MLG can be determined using the weights and balance manuals. In the chart in Section 7.11.1, for an aircraft with gross weight of 637,000 lb with 96.35% load on the main landing gear, the flexible pavement ACR on a high strength Code A subgrade is 350. In Section 7.11.8, the same aircraft on a rigid pavement with high strength Code A subgrade, has an ACR of 390.

The following table provides ACR data in tabular format. If the ACR for an intermediate weight between maximum taxi weight and the empty weight of the aircraft is required, Sections 7.11.1 through 7.11.14 should be consulted.

AIRCRAFT TYPE	MAXIMUM TAXI WEIGHT ----- MINIMUM WEIGHT *[1] lb (kg)	LOAD ON ONE MAIN GEAR LEG (%)	TIRE PRESSURE psi (MPa)	ACR FOR RIGID PAVEMENT SUBGRADES				ACR FOR FLEXIBLE PAVEMENT SUBGRADES			
				HIGH E = 200 MPa	MEDIUM E = 120 MPa	LOW E = 80 MPa	ULTRA LOW E = 50 MPa	HIGH E = 200 MPa	MEDIUM E = 120 MPa	LOW E = 80 MPa	ULTRA LOW E = 50 MPa
747-400B	878,200 (398,340)	23.31	200 (1.38)	480	520	610	840	590	690	770	860
	535,000 (242,670)	24.09		300	310	330	390	310	360	400	450
747-400BC	877,000 (397,800)	23.33	228 (1.57)	500	530	620	840	610	710	790	870
	565,000 (256,280)	24.09		330	330	360	420	350	400	440	500
747-400BCF	873,000 (395,990)	23.33	200 (1.38)	480	520	610	840	590	690	770	860
	610,000 (276,690)	24.09		340	360	390	470	370	430	480	540
747-400ER	913,000 (414,130)	23.40	228 (1.57)	520	560	660	910	650	750	840	920
	555,000 (251,740)	24.09		320	330	350	410	340	390	430	480
747-400ERF	913,000 (414,130)	23.40	228 (1.57)	520	560	660	910	650	750	840	920
	611,000 (277,140)	24.09		350	360	390	470	390	440	490	550
747-400F	878,000 (398,250)	23.32	200 (1.38)	480	520	610	840	590	690	770	860
	395,000 (179,170)	24.09		220	230	230	260	220	240	260	300
747-400LCF	803,000 (364,230)	23.03	189 (1.30)	420	460	530	690	500	590	660	740
	400,000 (181,440)	24.09		220	230	240	260	220	240	260	300

*[1] Minimum weight used solely as a baseline for ACN curve generation.

7.11.1 Aircraft Classification Rating - Flexible Pavement: Model 747-400B

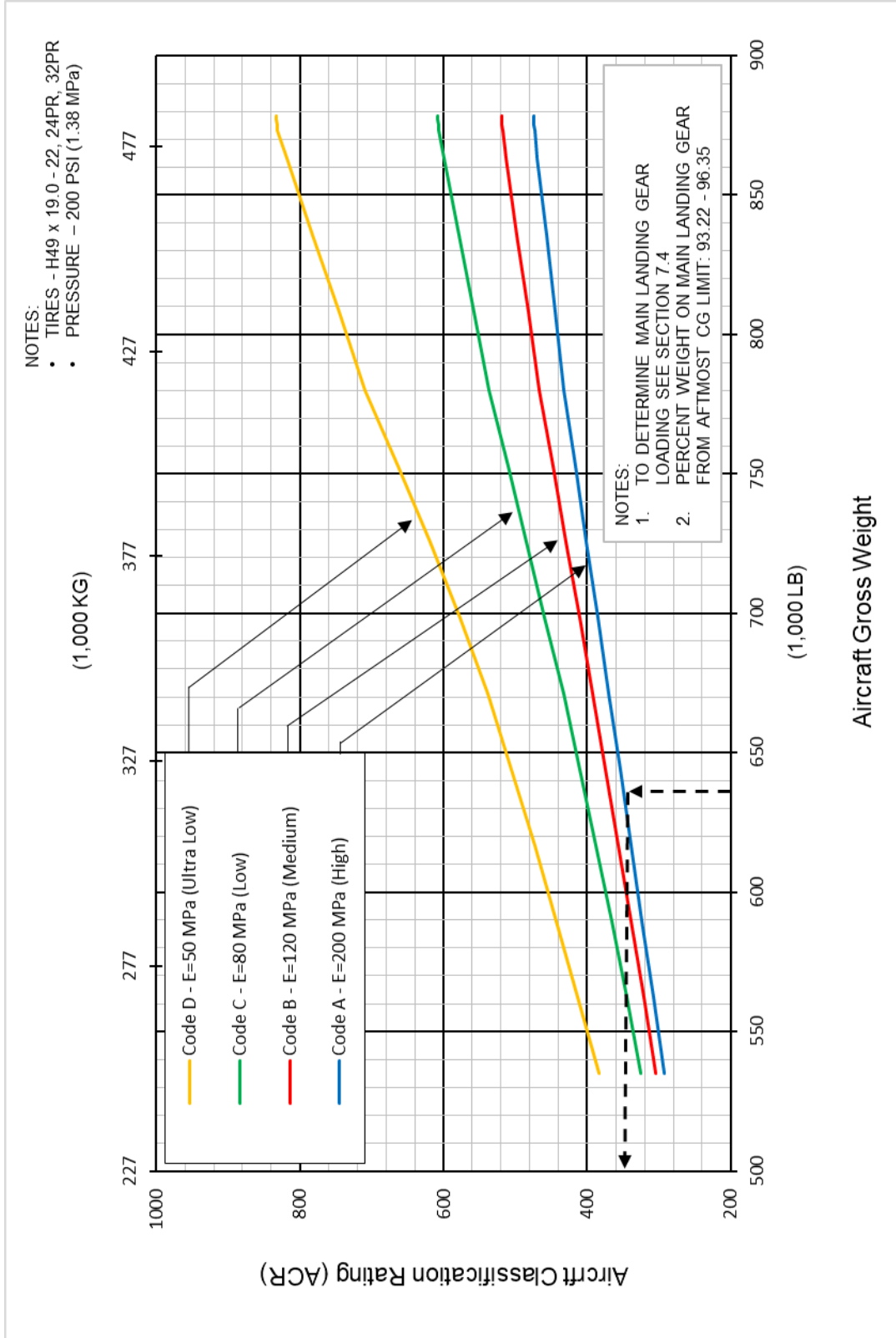

D6-58326-1

7.11.2 Aircraft Classification Rating - Flexible Pavement: Model 747-400BC

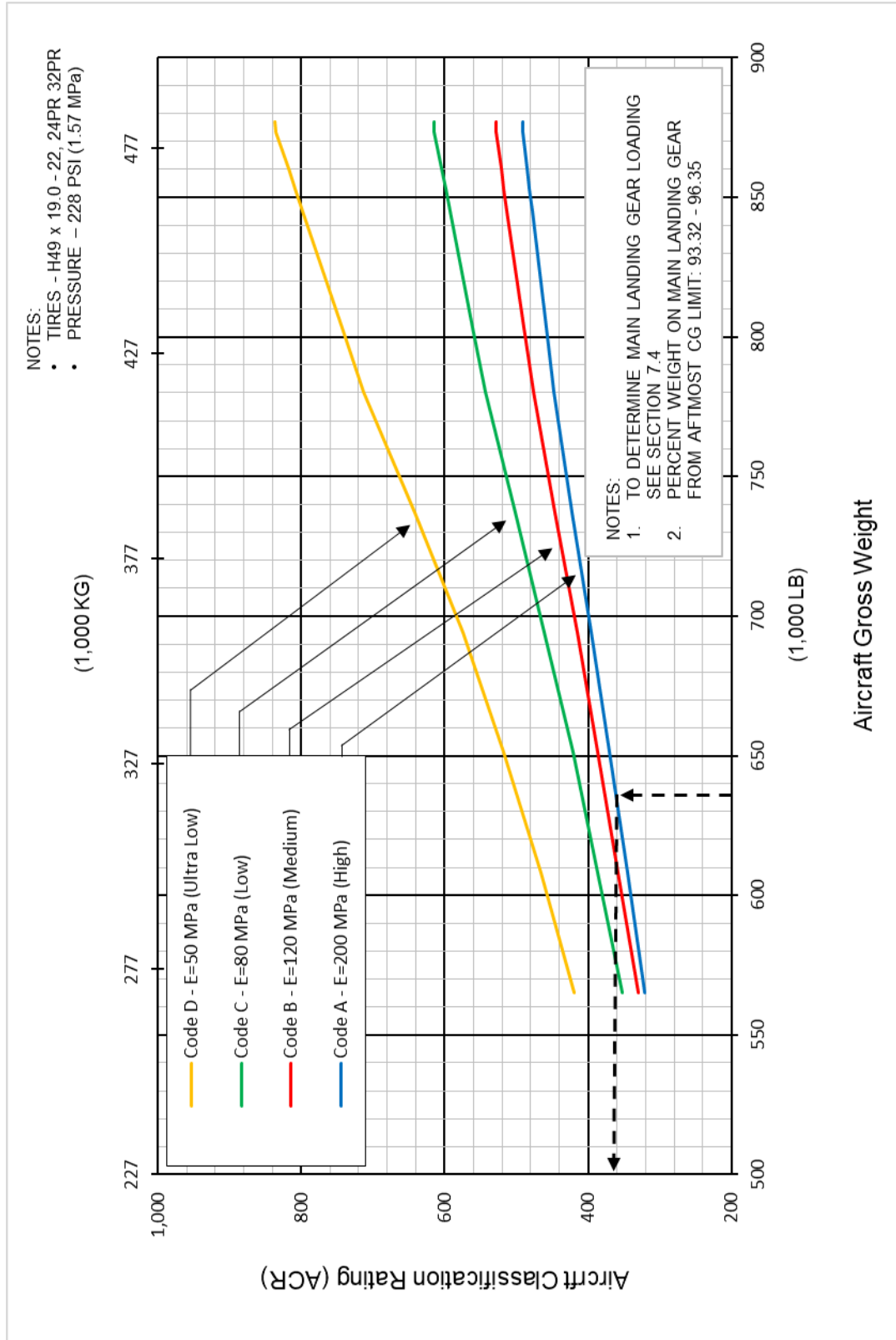

D6-58326-1

7.11.3 Aircraft Classification Rating - Flexible Pavement: Model 747-400BCF

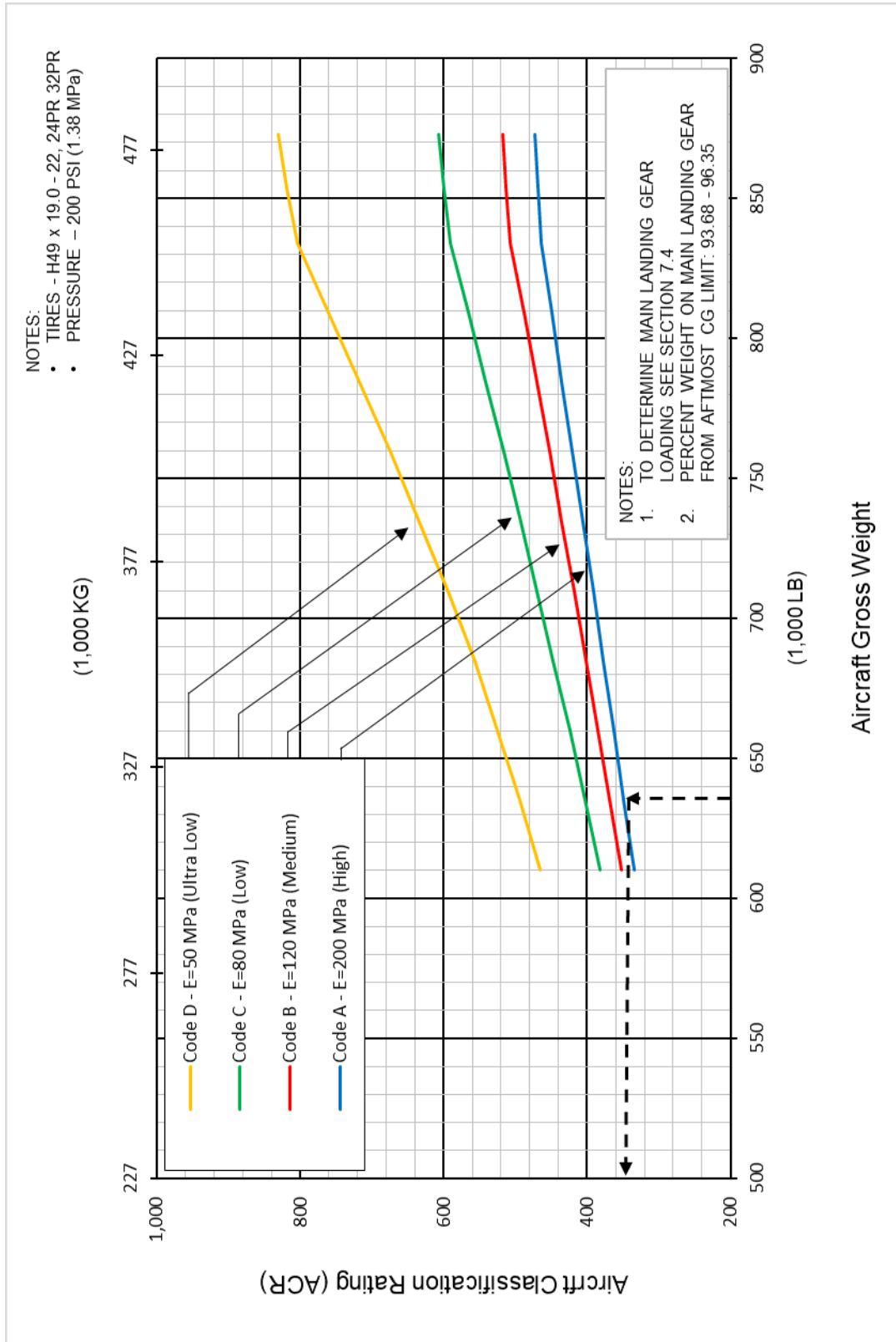

D6-58326-1

7.11.4 Aircraft Classification Rating - Flexible Pavement: Model 747-400ER

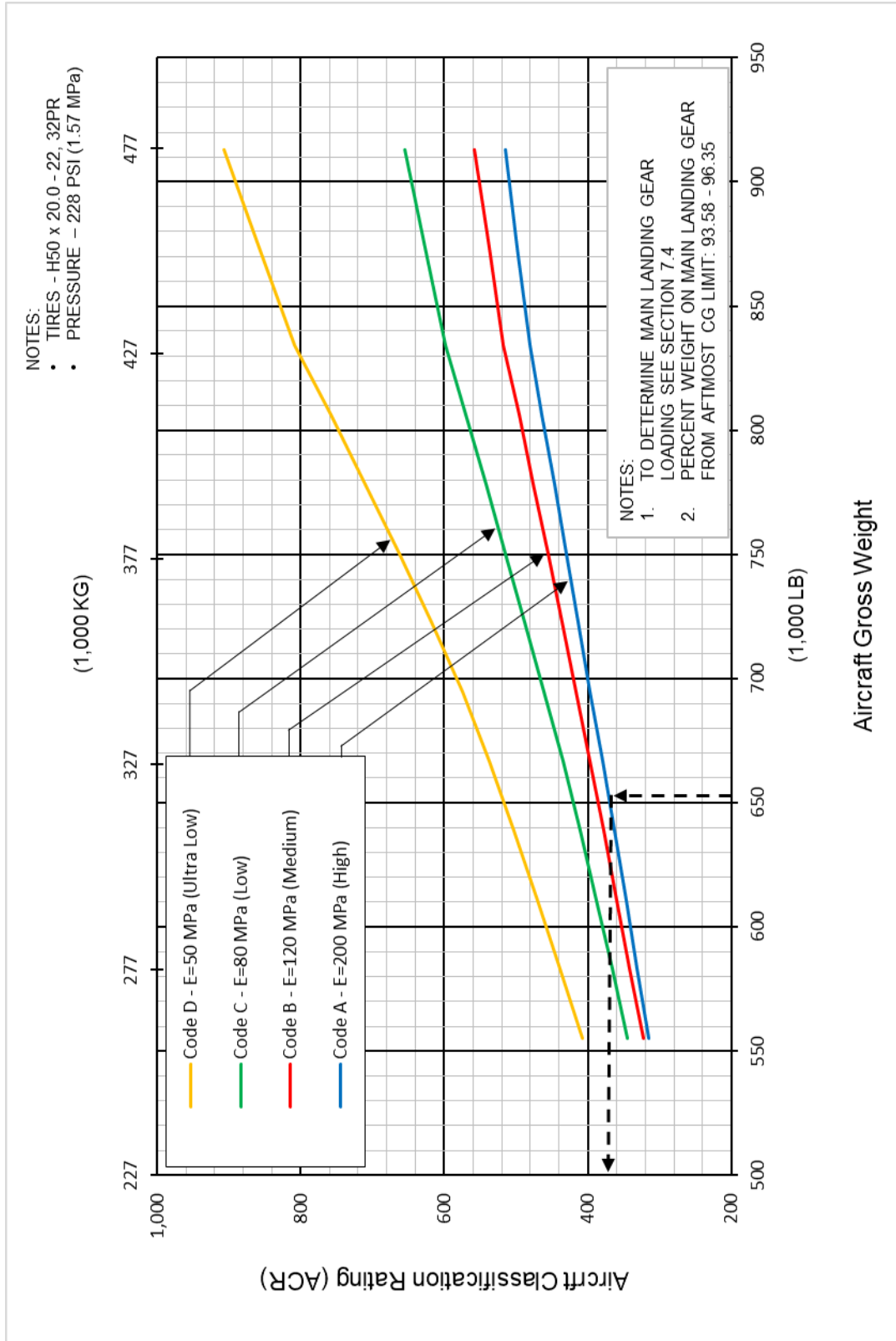

D6-58326-1

7.11.5 Aircraft Classification Rating - Flexible Pavement: Model 747-400ERF

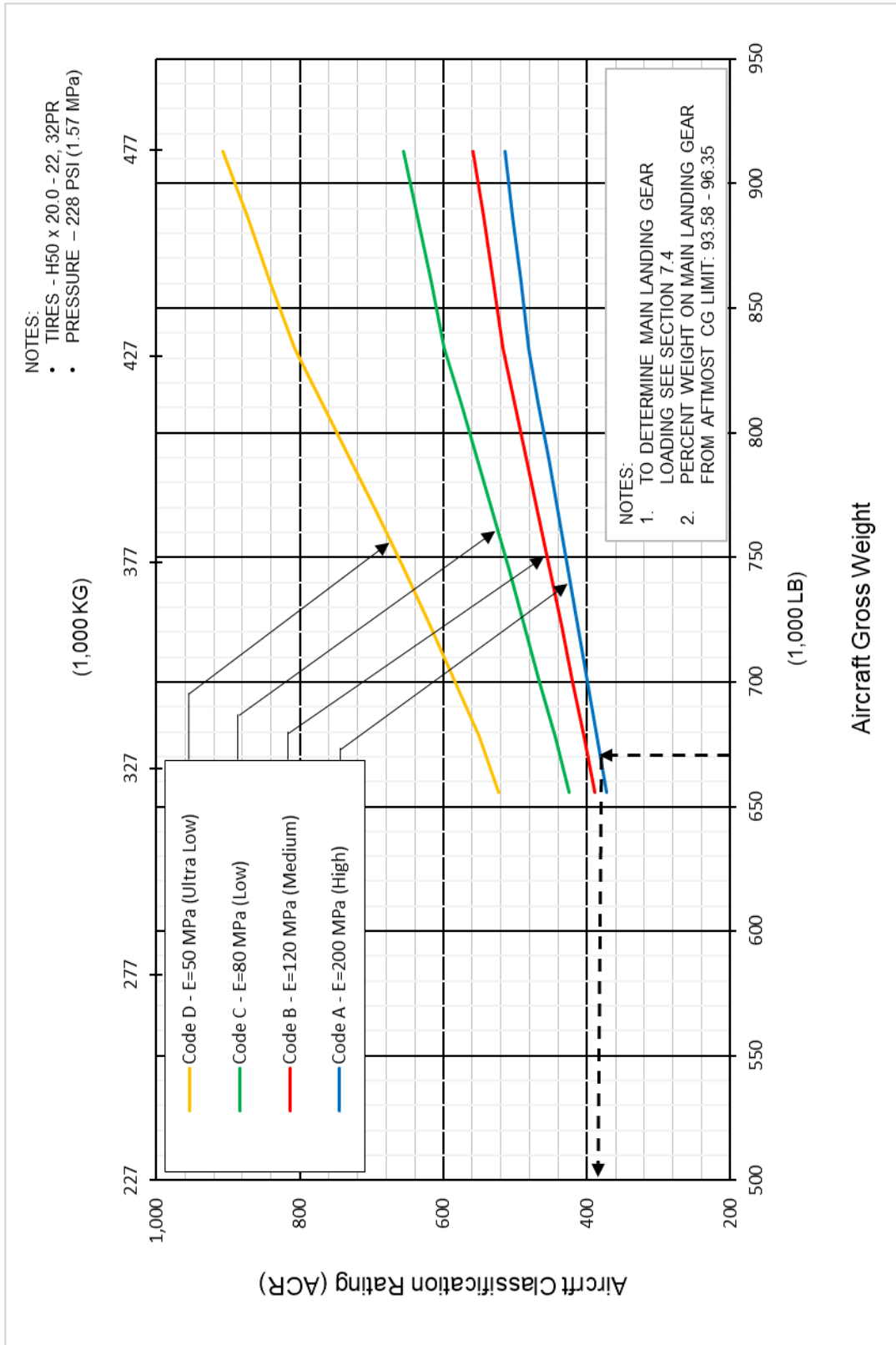

D6-58326-1

7.11.6 Aircraft Classification Rating - Flexible Pavement: Model 747-400F

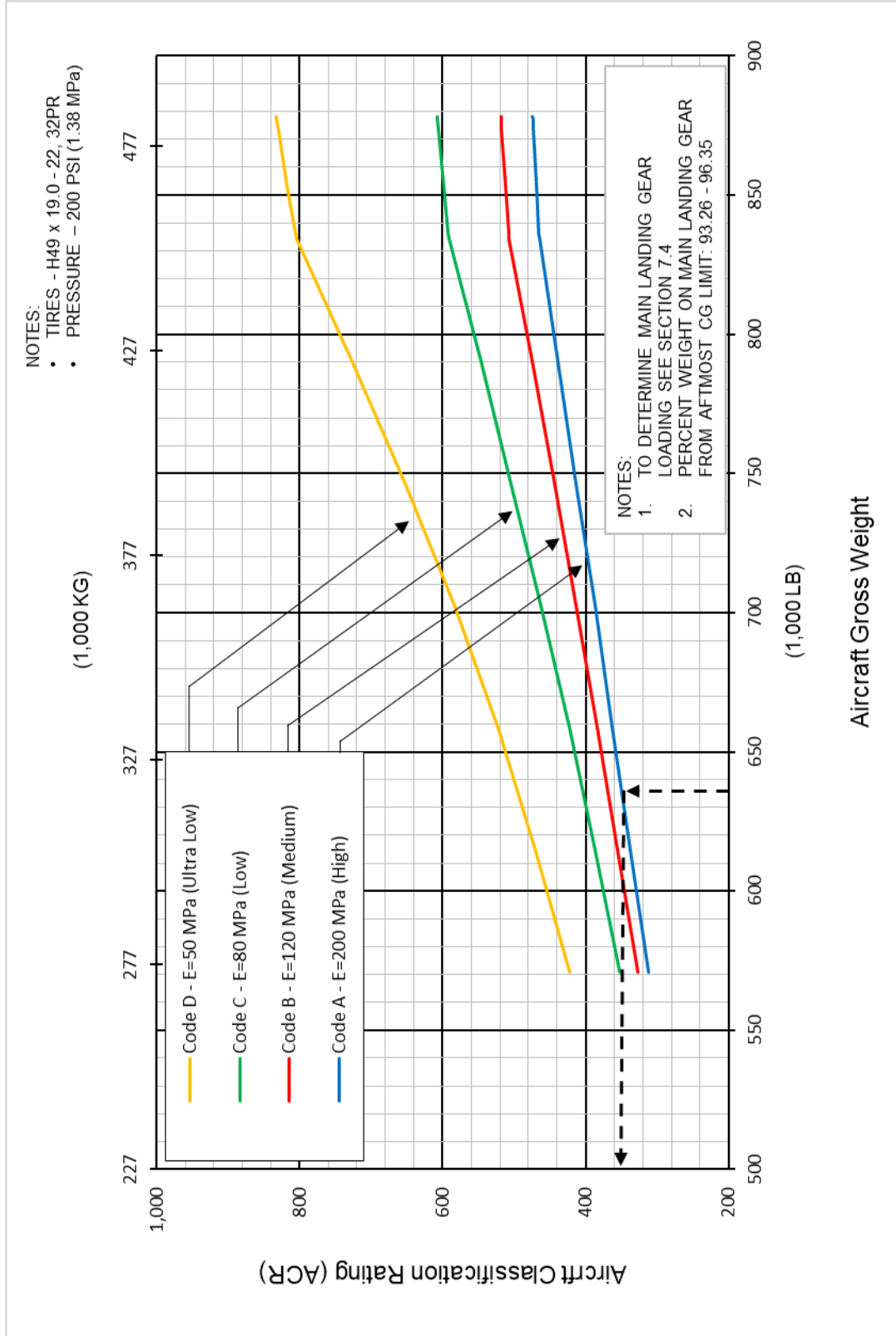

D6-58326-1

7.11.7 Aircraft Classification Rating - Flexible Pavement: Model 747-400LCF

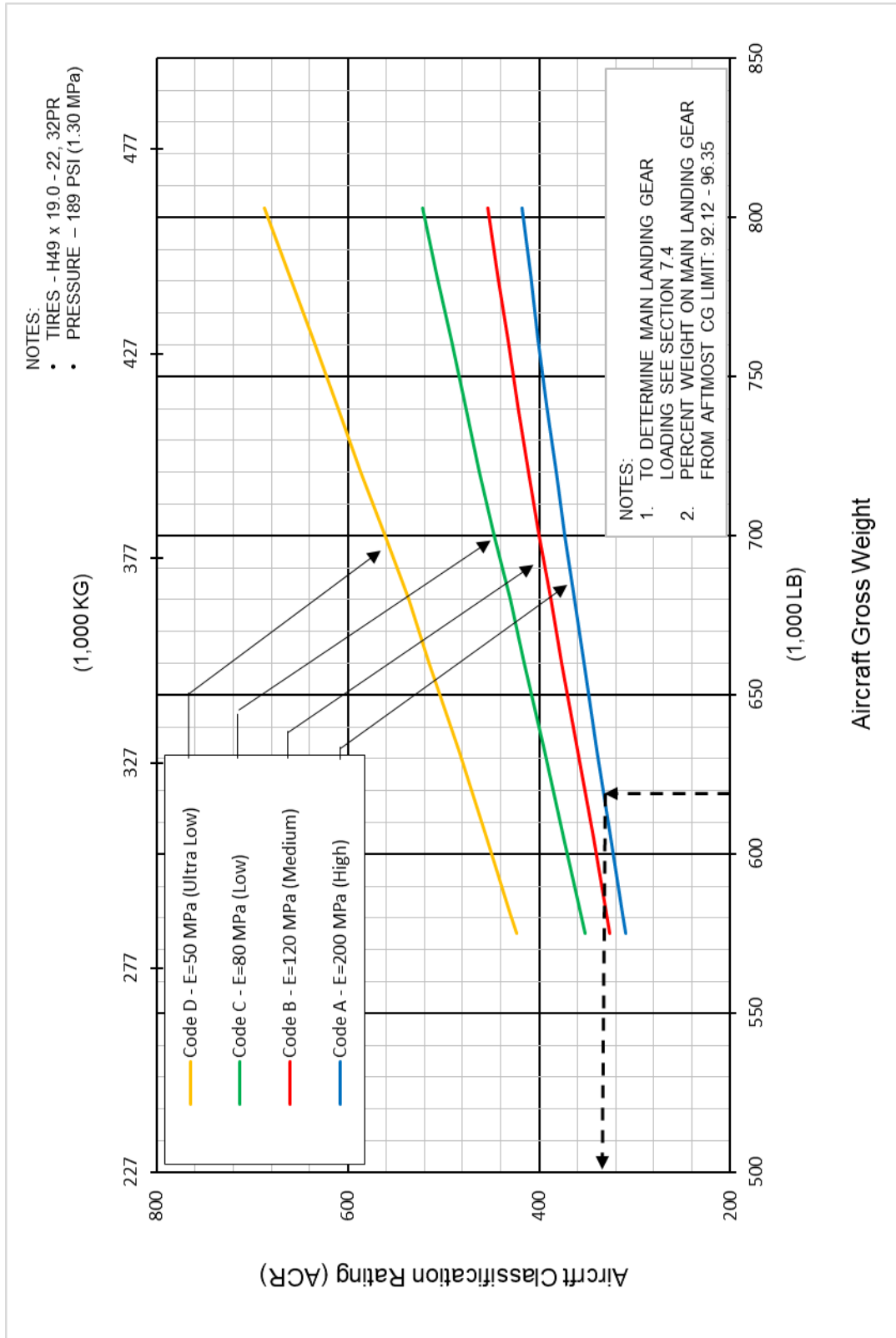

D6-58326-1

7.11.8 Aircraft Classification Rating - Rigid Pavement: Model 747-400B

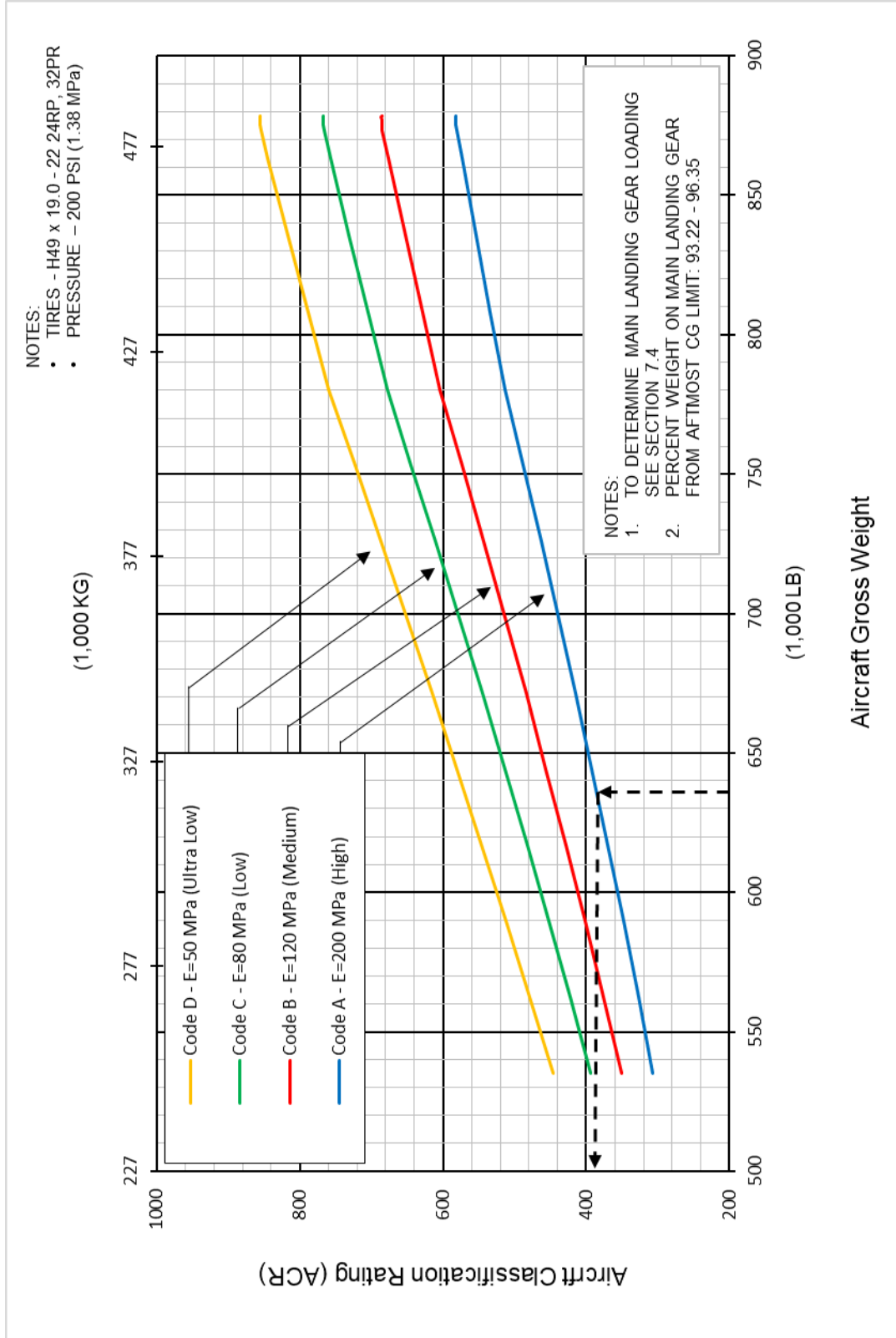

D6-58326-1

7.11.9 Aircraft Classification Rating - Rigid Pavement: Model 747-400BC

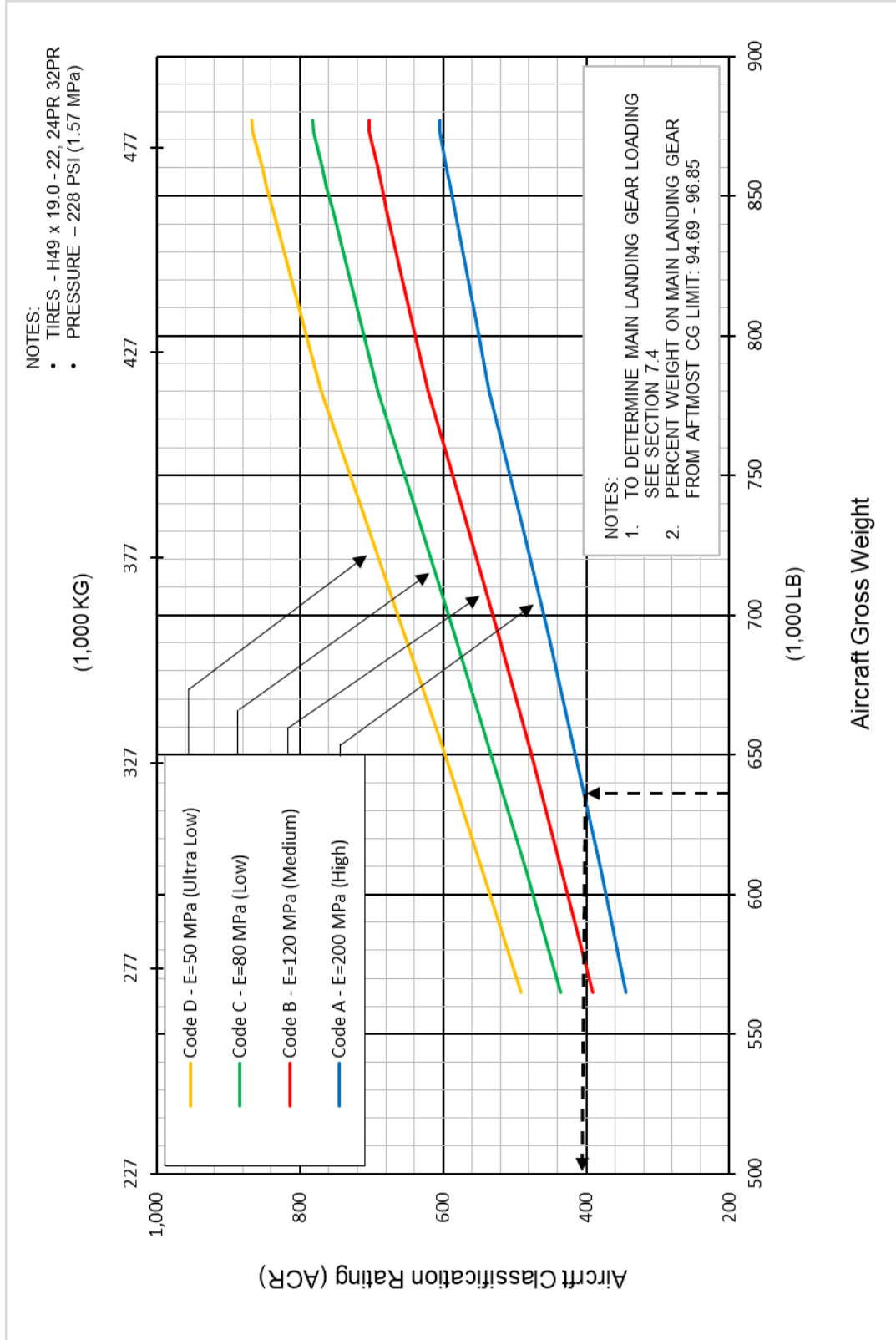

D6-58326-1

7.11.10 Aircraft Classification Rating - Rigid Pavement: Model 747-400BCF

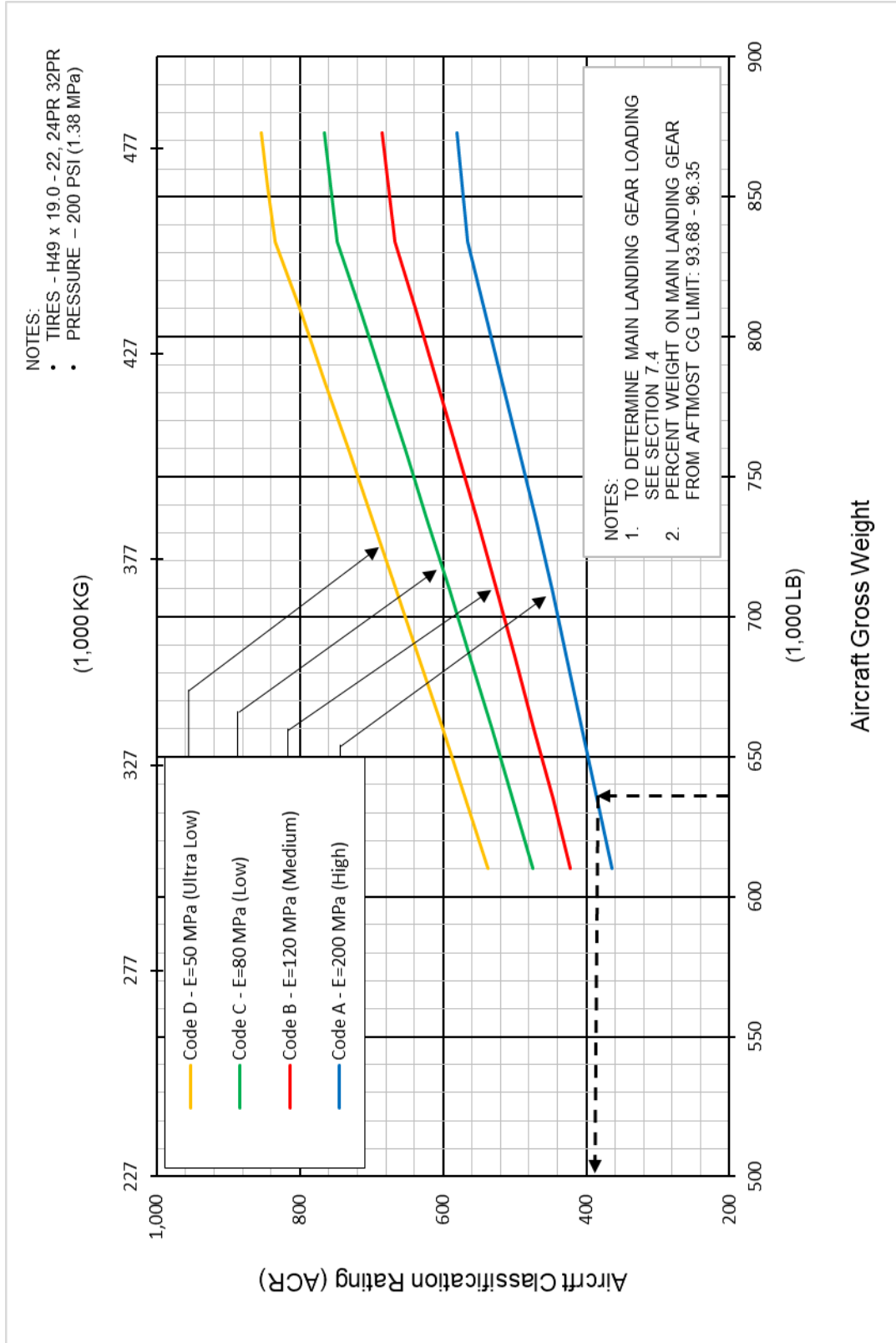

D6-58326-1

7.11.11 Aircraft Classification Rating - Rigid Pavement: Model 747-400ER

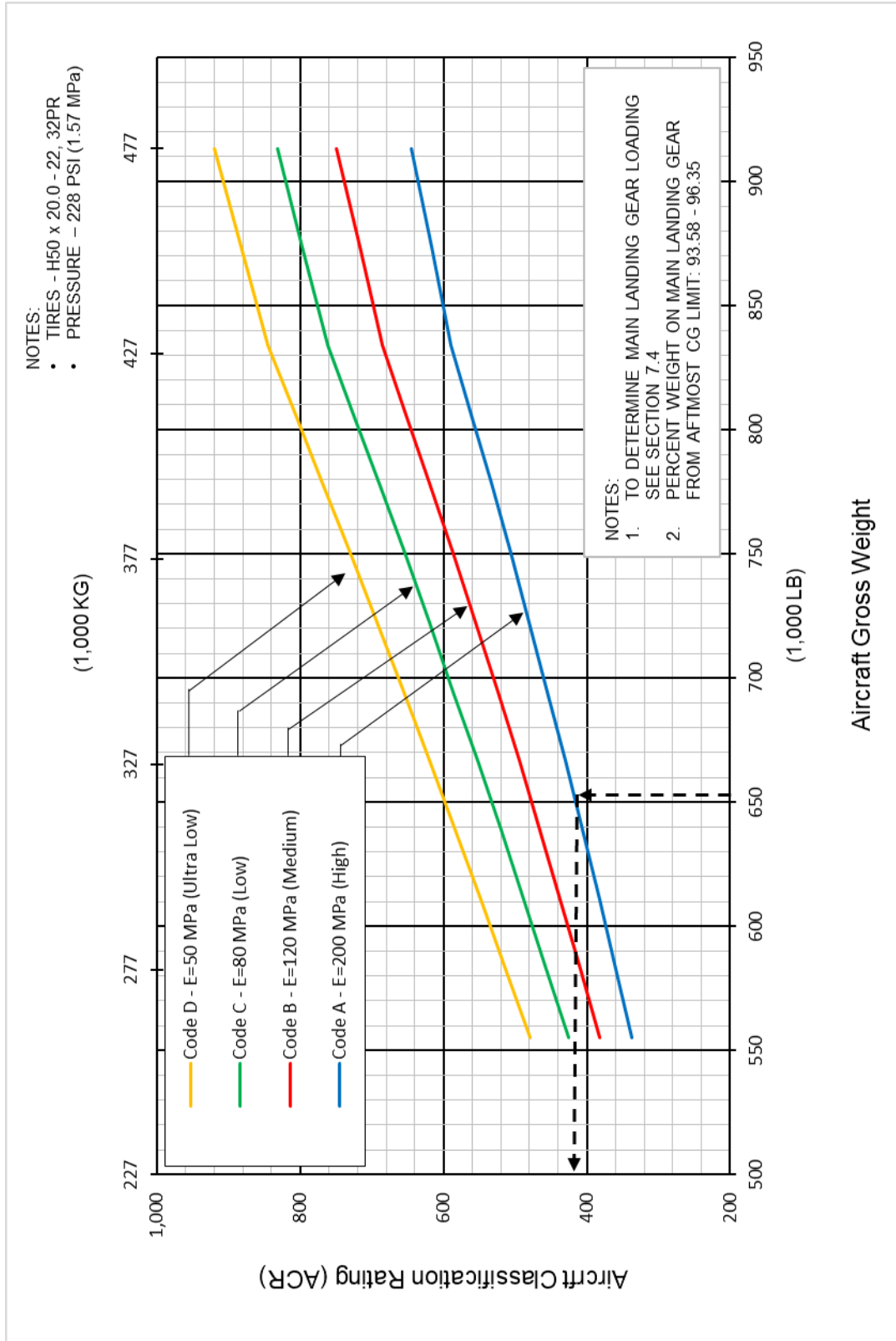

D6-58326-1

7.11.12 Aircraft Classification Rating - Rigid Pavement: Model 747-400ERF

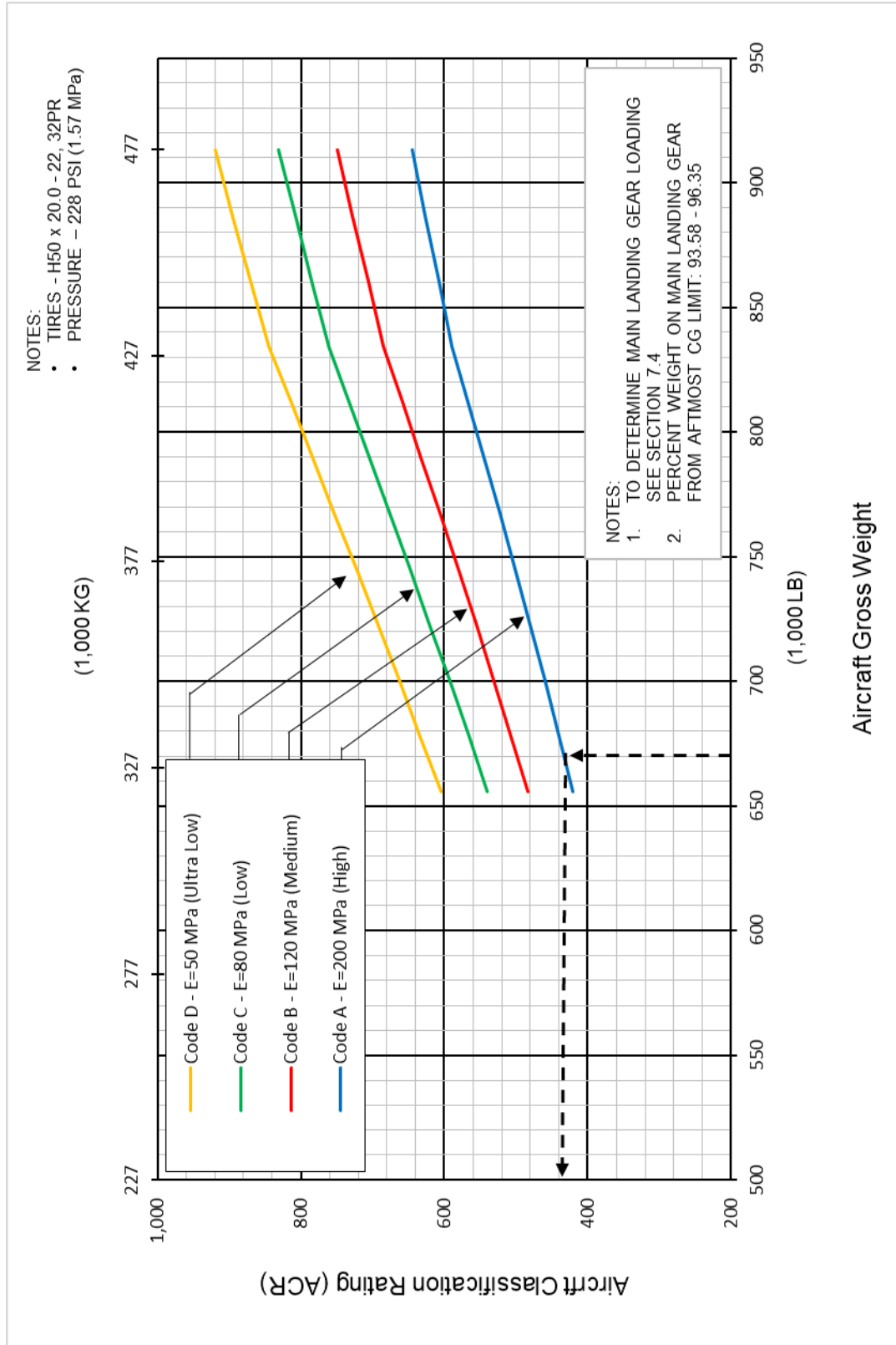

D6-58326-1

7.11.13 Aircraft Classification Rating - Rigid Pavement: Model 747-400F

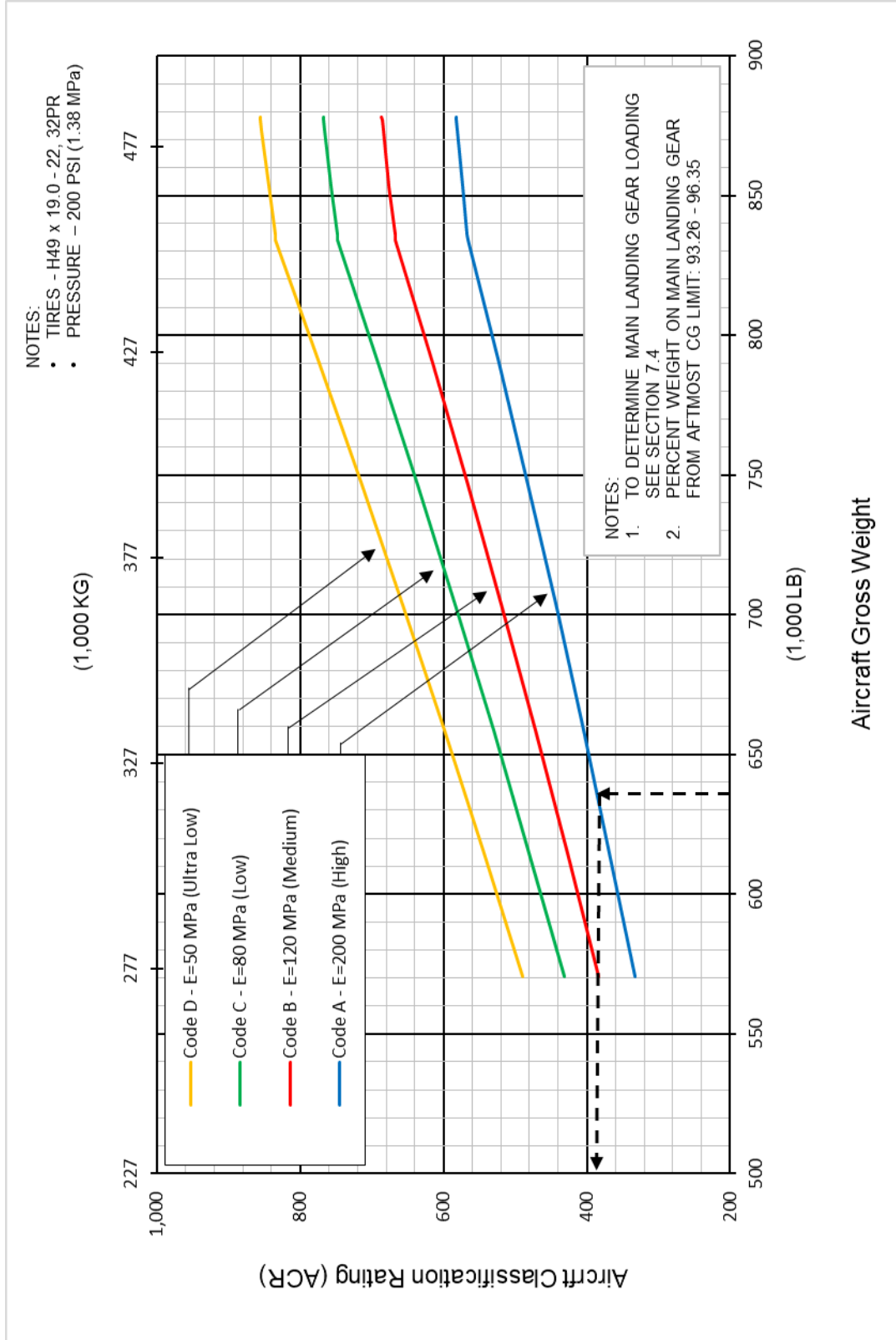

D6-58326-1

7.11.14 Aircraft Classification Rating - Rigid Pavement: Model 747-400LCF

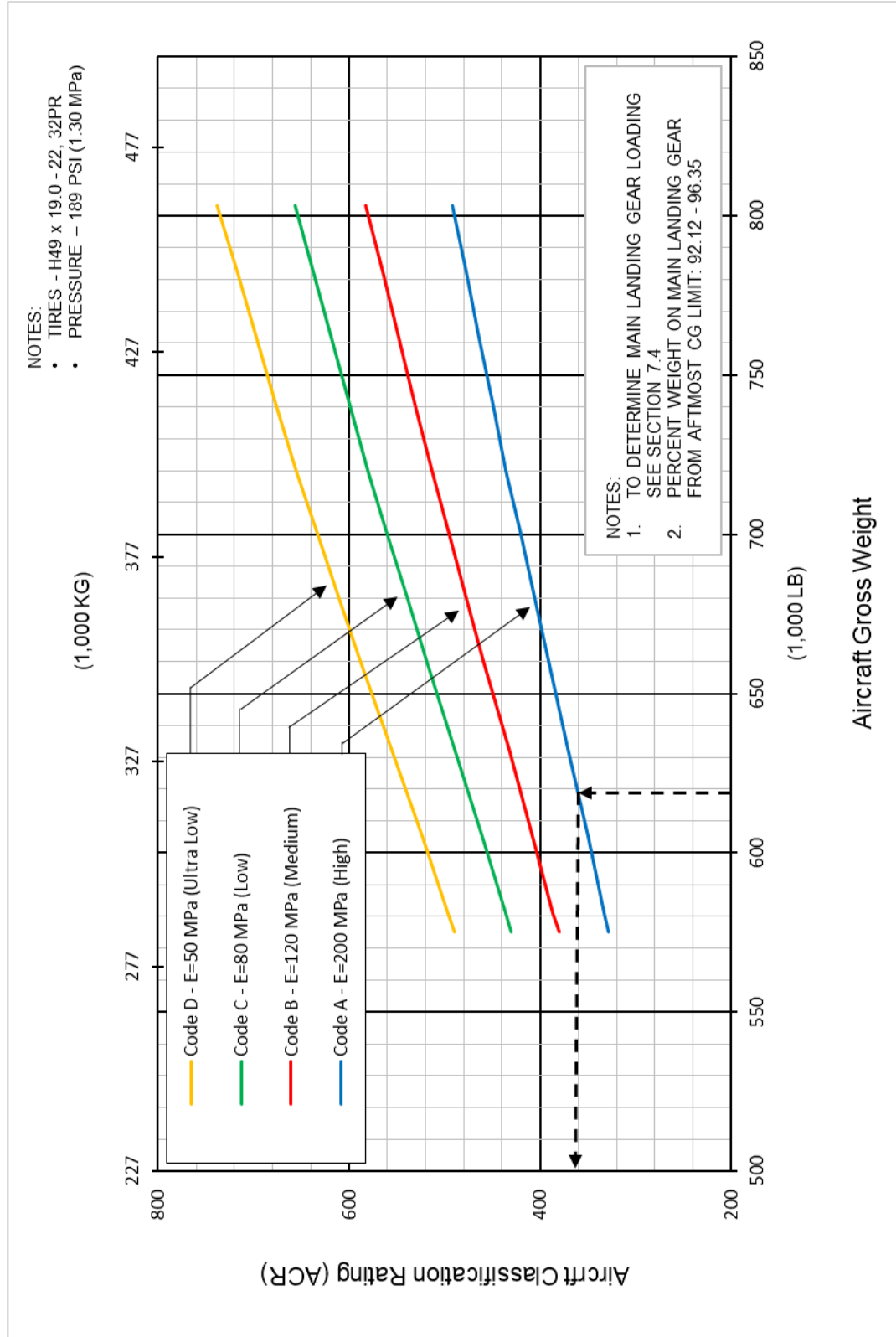

D6-58326-1

8.0 FUTURE 747 DERIVATIVE AIRPLANES

Several derivatives are being studied to provide additional capabilities of the 747 family of airplanes.

Additional seating capacity could be obtained by conventional body extensions or by upper deck extensions. A 31-foot body stretch with a partial stretched upper deck could provide an increase of 150 passengers over the 747-400. Studies have verified that body length increases up to 50 feet are technically feasible. Landing gear wheel base would be modified accordingly. Full-length extension of the upper deck is an alternate method of increasing seating capacity. This could provide 650 total seats without increasing overall body length. Double deck configurations with moderate body extensions could provide mixed-class seating capacities in excess of 700.

Where current range capability can be traded for increased payloads, existing maximum gross weight will suffice and no wing dimensional changes are necessary. Where range must be maintained with substantial payload increases, gross weights close to 1,000,000 pounds are possible with new-generation wings, with potential increases in wingspan. As airplane weight and size increase, planned thrust growth of current engines will provide takeoff performance equal to or greater than that of current models, and the required pavement thickness can be controlled by landing gear configurations.

Future growth versions could also require increased tail heights depending on body length, engine size, and more outboard engine placement resulting from the increased wingspan.

The above discussion covers 747 growth possibilities. Whether and/or when these or other possibilities are actually built is entirely dependent on future airline requirements. In any event, the impact on airport facilities will be a consideration in configuration and design.

9.0 SCALED 747-400 DRAWINGS

The drawings in the following pages show airplane plan view drawings, drawn to approximate scale as noted. The drawings may not come out to exact scale when printed or copied from this document. Printing scale should be adjusted when attempting to reproduce these drawings. Three-view drawing files of the 747-400, along with other Boeing airplane models, can be downloaded from the following website:

<http://www.boeing.com/airports>

9.1 MODEL 747-400, -400 COMBI, -400ER

9.1.1 Scaled Drawings – 1 IN. = 32 FT: Model 747-400, -400 Combi, -400ER

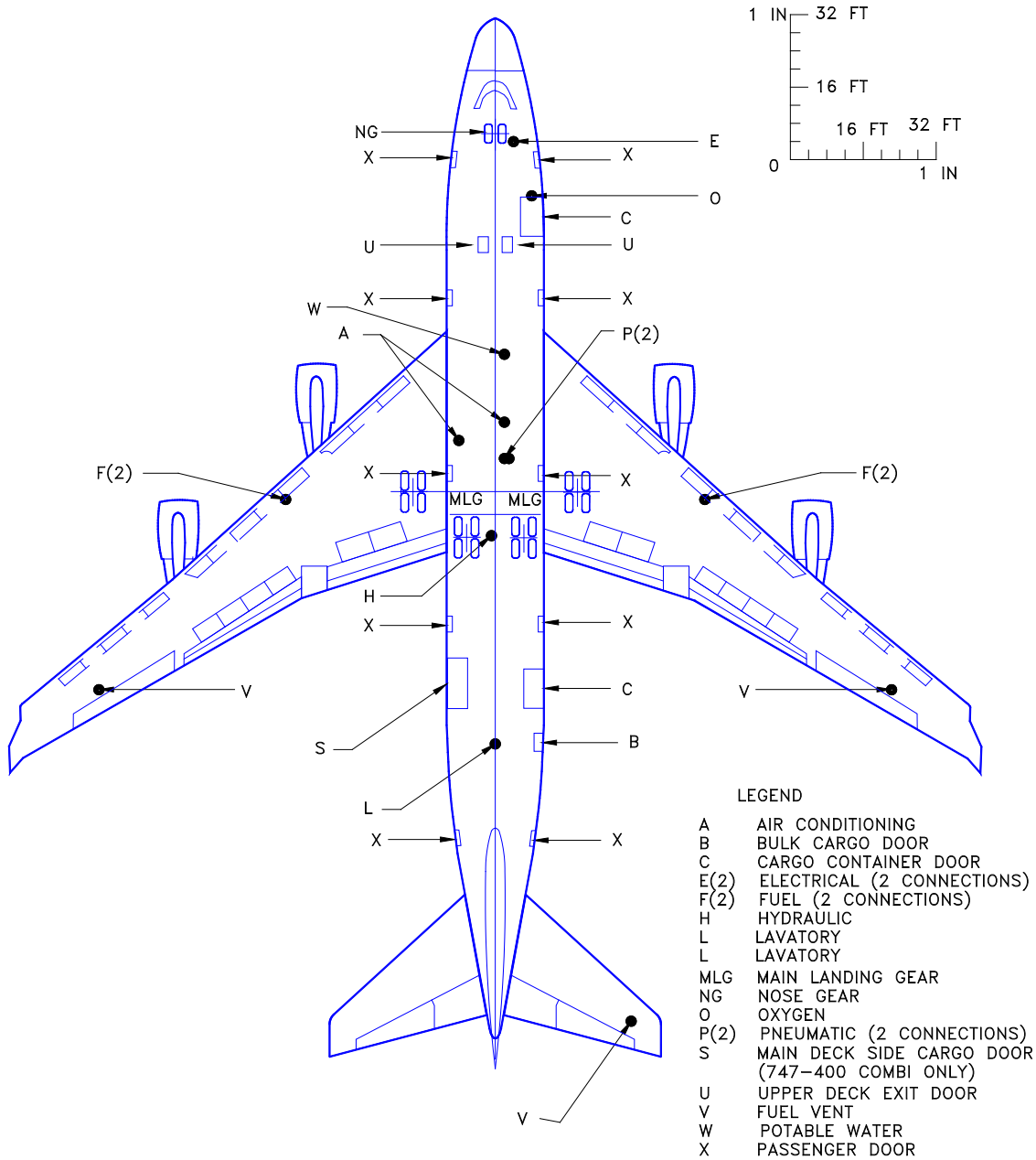

NOTE: ADJUST FOR PROPER SCALING WHEN PRINTING THIS PAGE

9.1.2 Scaled Drawings – 1 IN. = 32 FT: Model 747-400, -400 Combi, -400ER

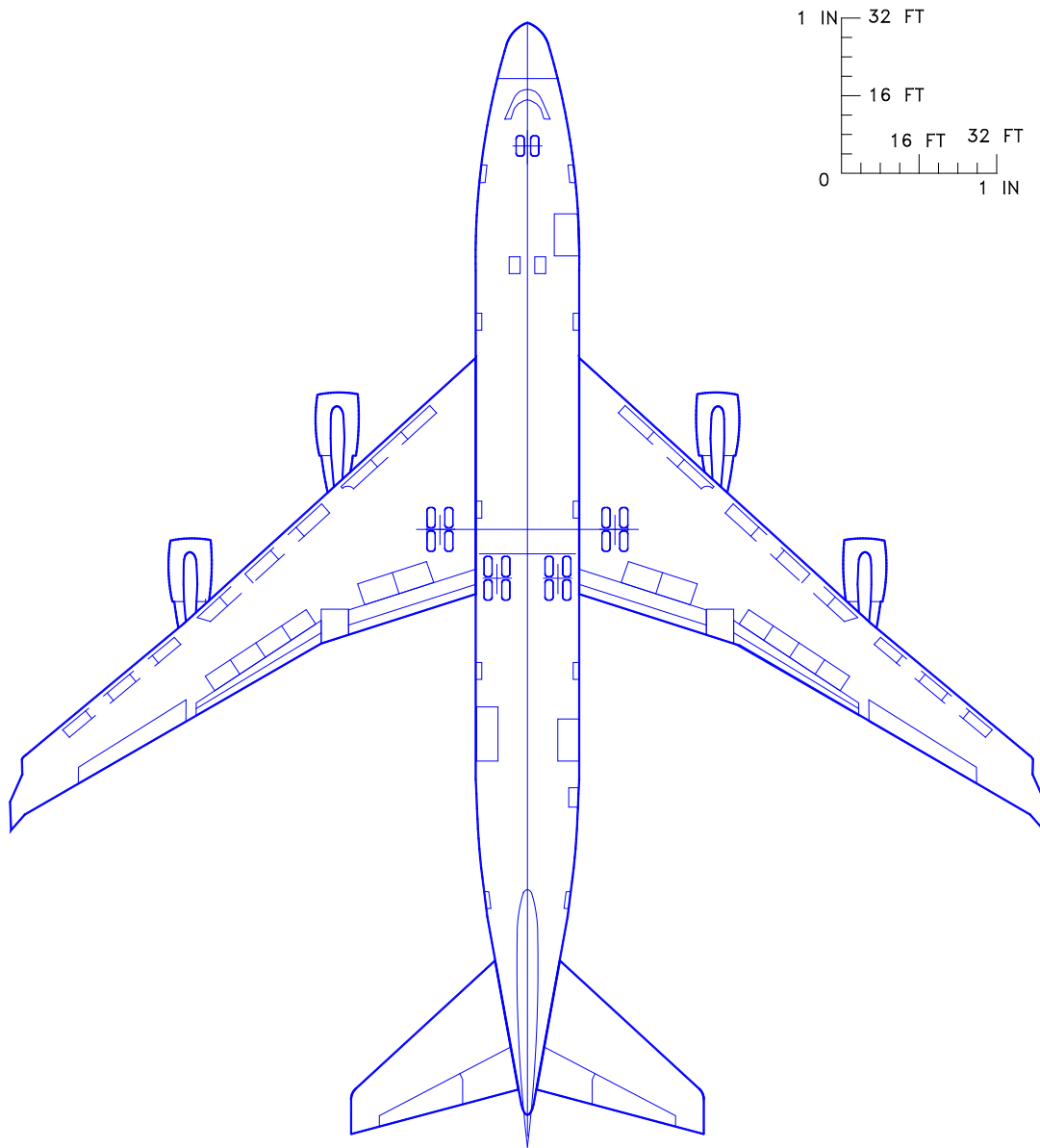

NOTE: ADJUST FOR PROPER SCALING WHEN PRINTING THIS PAGE

9.1.3 Scaled Drawings – 1 IN. = 50 FT: Model 747-400, -400 Combi, -400ER

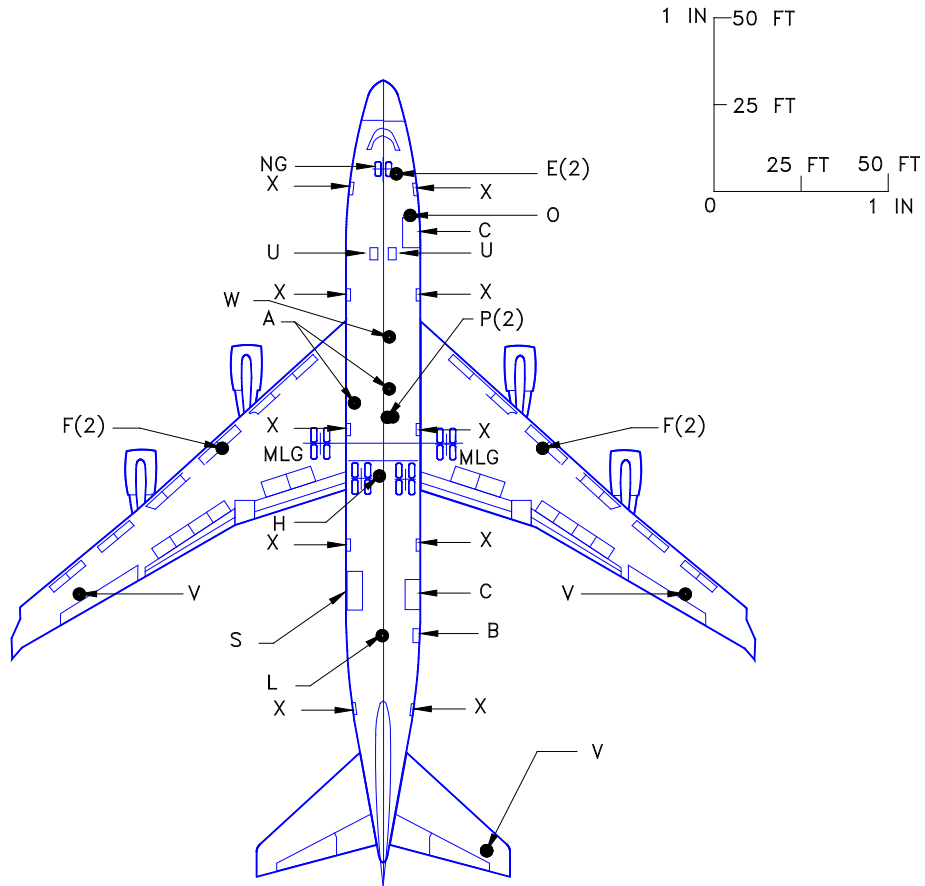

LEGEND

- A AIR CONDITIONING
- B BULK CARGO DOOR
- C CARGO CONTAINER DOOR
- E(2) ELECTRICAL (2 CONNECTIONS)
- F(2) FUEL (2 CONNECTIONS)
- H HYDRAULIC
- L LAVATORY
- MLG MAIN LANDING GEAR
- NG NOSE GEAR
- O OXYGEN
- P(2) PNEUMATIC (2 CONNECTIONS)
- S MAIN DECK SIDE CARGO DOOR
(747-400 COMBI ONLY)
- U UPPER DECK EXIT DOOR
- V FUEL VENT
- W POTABLE WATER
- X PASSENGER DOOR

NOTE: ADJUST FOR PROPER SCALING WHEN PRINTING THIS PAGE

D6-58326-1

9.1.4 Scaled Drawings – 1 IN. = 50 FT: Model 747-400, -400 Combi, -400ER

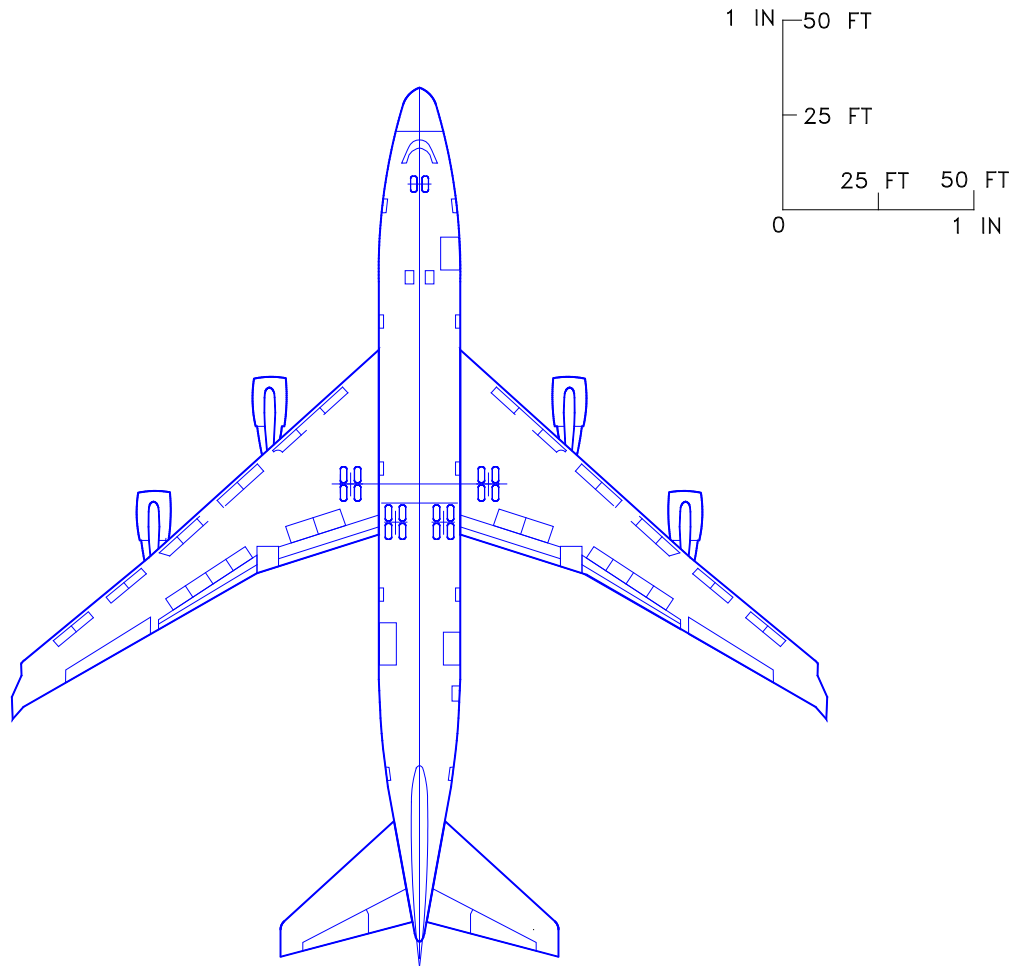

NOTE: ADJUST FOR PROPER SCALING WHEN PRINTING THIS PAGE

9.1.5 Scaled Drawings – 1 IN. = 100 FT: Model 747-400, -400 Combi, -400ER

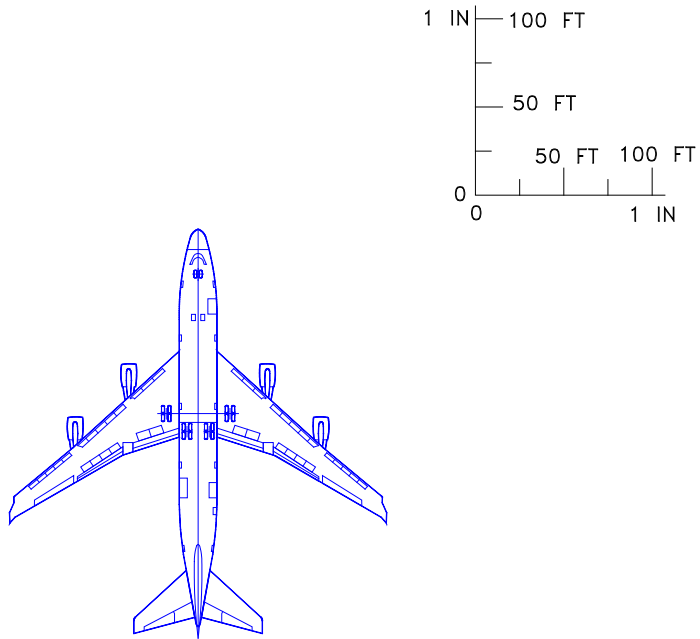

NOTE:
SEE SEC 9.1.1 FOR IDENTIFICATION
OF LEGEND LOCATIONS

LEGEND

- A AIR CONDITIONING
- B BULK CARGO DOOR
- C CARGO CONTAINER DOOR
- E(2) ELECTRICAL (2 CONNECTIONS)
- F(2) FUEL (2 CONNECTIONS)
- H HYDRAULIC
- L LAVATORY
- MLG MAIN LANDING GEAR
- NG NOSE GEAR
- O OXYGEN
- P(2) PNEUMATIC (2 CONNECTIONS)
- S MAIN DECK SIDE CARGO DOOR
(747-400 COMBI ONLY)
- U UPPER DECK EXIT DOOR
- V FUEL VENT
- W POTABLE WATER
- X PASSENGER DOOR

NOTE: ADJUST FOR PROPER SCALING WHEN PRINTING THIS PAGE

9.1.6 Scaled Drawings – 1 IN. = 100 FT: Model 747-400, -400 Combi, -400ER

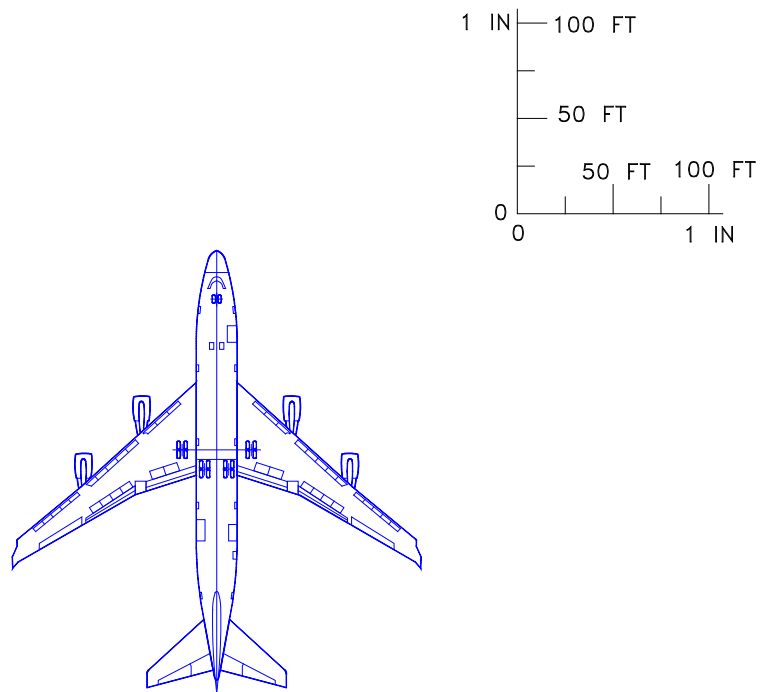

NOTE: ADJUST FOR PROPER SCALING WHEN PRINTING THIS PAGE

9.1.7 Scaled Drawings – 1:500: Model 747-400, -400 Combi, -400ER

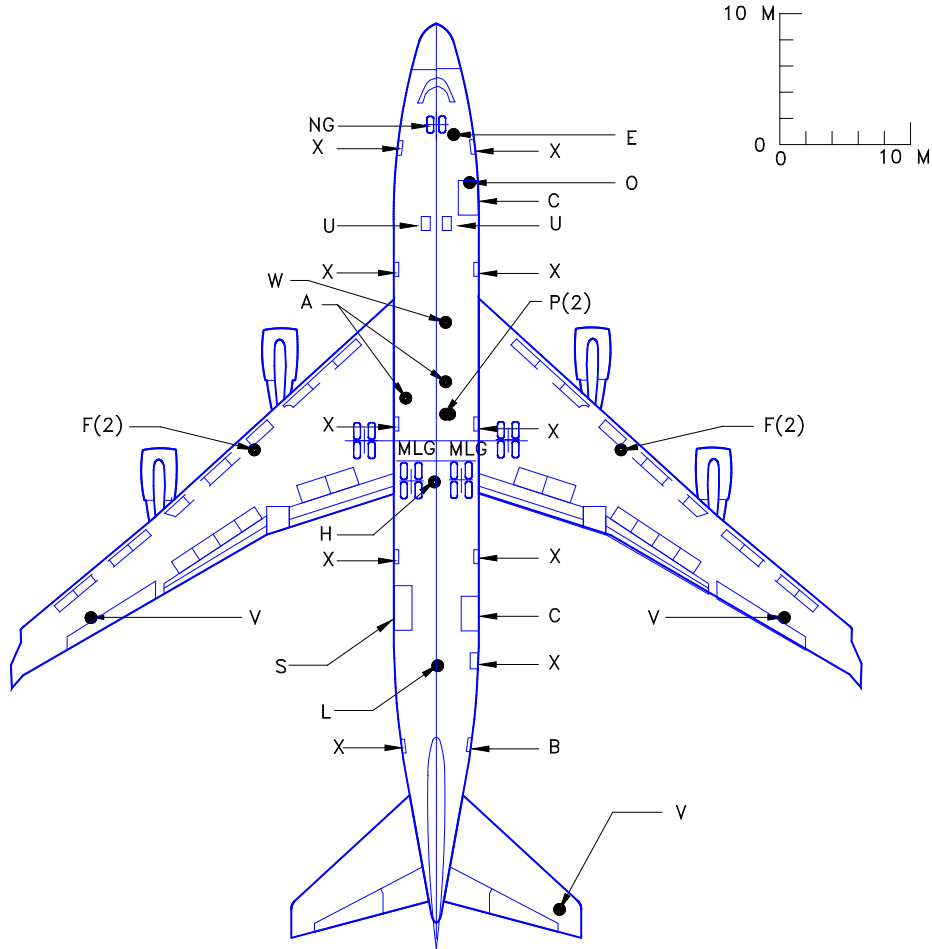

LEGEND

- A AIR CONDITIONING
- B BULK CARGO DOOR
- C CARGO CONTAINER DOOR
- E(2) ELECTRICAL (2 CONNECTIONS)
- F(2) FUEL (2 CONNECTIONS)
- H HYDRAULIC
- L LAVATORY
- MLG MAIN LANDING GEAR
- NG NOSE GEAR
- O OXYGEN
- P(2) PNEUMATIC (2 CONNECTIONS)
- S MAIN DECK SIDE CARGO DOOR (747-400 COMBI ONLY)
- U UPPER DECK EXIT DOOR
- V FUEL VENT
- W POTABLE WATER
- X PASSENGER DOOR

NOTE: ADJUST FOR PROPER SCALING WHEN PRINTING THIS PAGE

9.1.8 Scaled Drawings – 1:500: Model 747-400, -400 Combi, -400ER

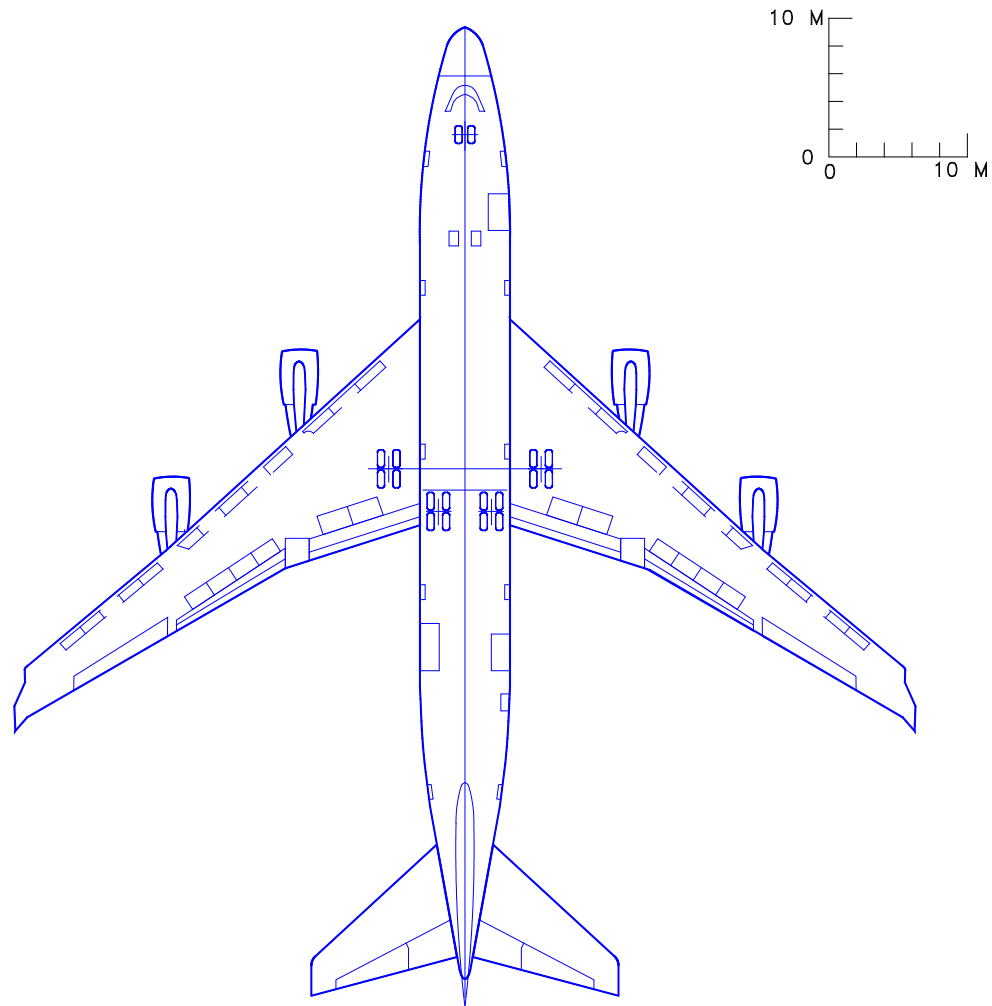

NOTE: ADJUST FOR PROPER SCALING WHEN PRINTING THIS PAGE

9.1.9 Scaled Drawings – 1:1000: Model 747-400, -400 Combi, -400ER

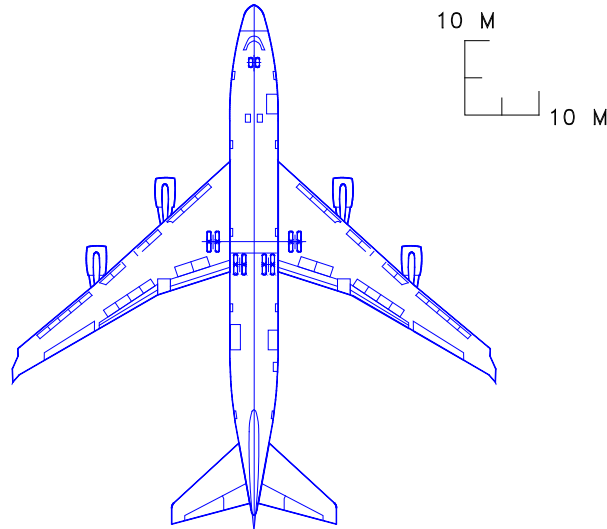

NOTE:
SEE SEC 9.1.1 FOR IDENTIFICATION
OF LEGEND LOCATIONS

LEGEND

A	AIR CONDITIONING
B	BULK CARGO DOOR
C	CARGO CONTAINER DOOR
E(2)	ELECTRICAL (2 CONNECTIONS)
F(2)	FUEL (2 CONNECTIONS)
H	HYDRAULIC
L	LAVATORY
MLG	MAIN LANDING GEAR
NG	NOSE GEAR
O	OXYGEN
P(2)	PNEUMATIC (2 CONNECTIONS)
S	MAIN DECK SIDE CARGO DOOR (747-400 COMBI ONLY)
U	UPPER DECK EXIT DOOR
V	FUEL VENT
W	POTABLE WATER
X	PASSENGER DOOR

NOTE: ADJUST FOR PROPER SCALING WHEN PRINTING THIS PAGE

9.1.10 Scaled Drawings – 1:1000: Model 747-400, -400 Combi, -400ER

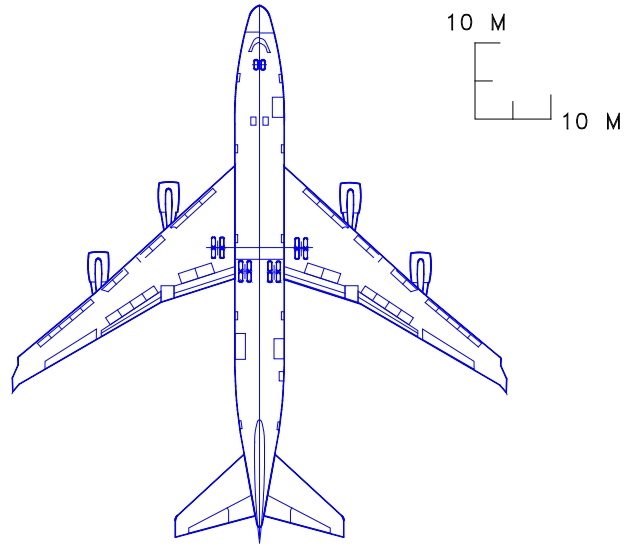

NOTE: ADJUST FOR PROPER SCALING WHEN PRINTING THIS PAGE

9.2 MODEL 747-400 FREIGHTER, -400ER FREIGHTER

9.2.1 Scaled Drawings – 1 IN. = 32 FT: Model 747-400 Freighter, -400ER Freighter

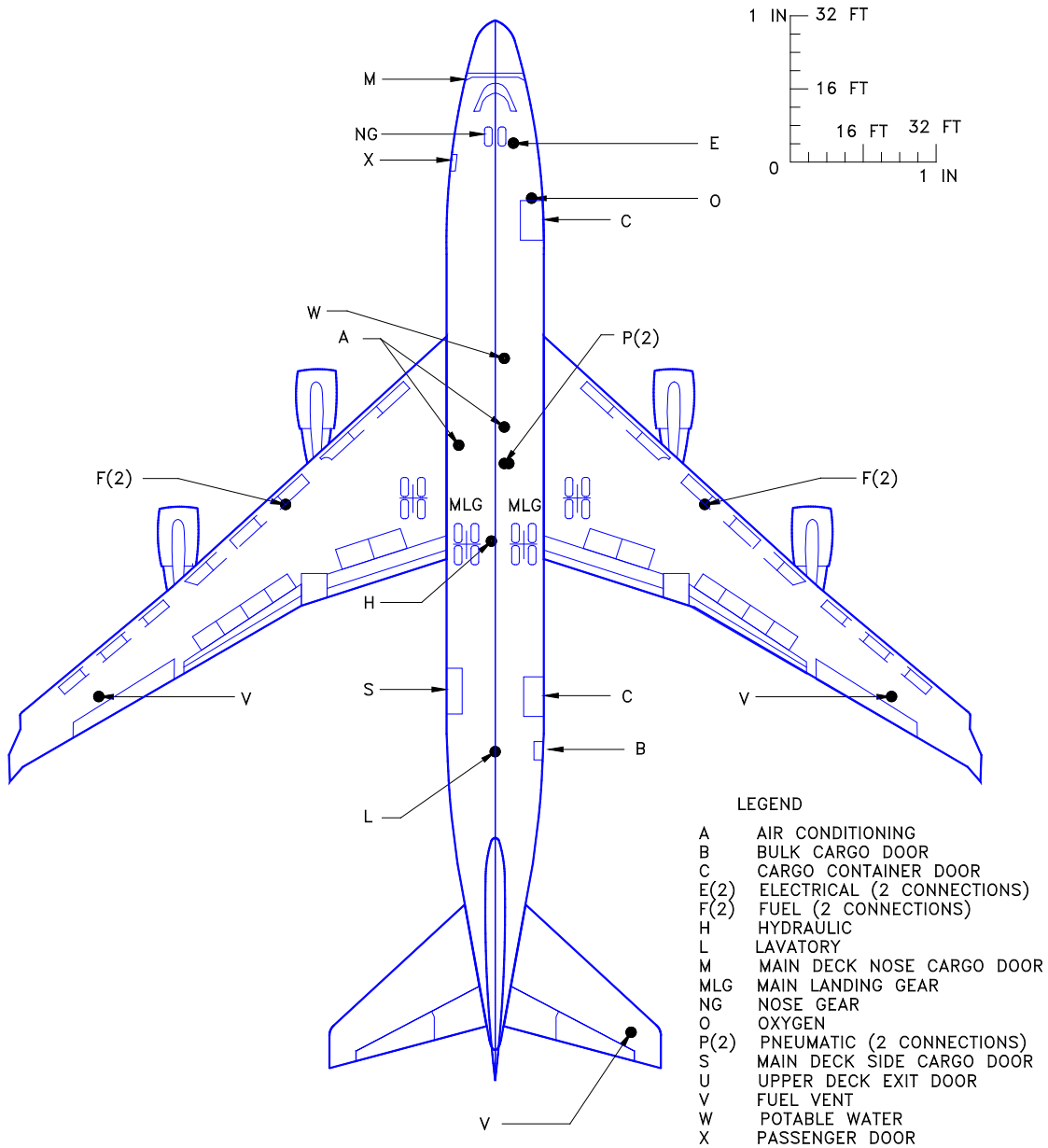

NOTE: ADJUST FOR PROPER SCALING WHEN PRINTING THIS PAGE

9.2.2 Scaled Drawings – 1 IN. = 32 FT: Model 747-400 Freighter, -400ER Freighter

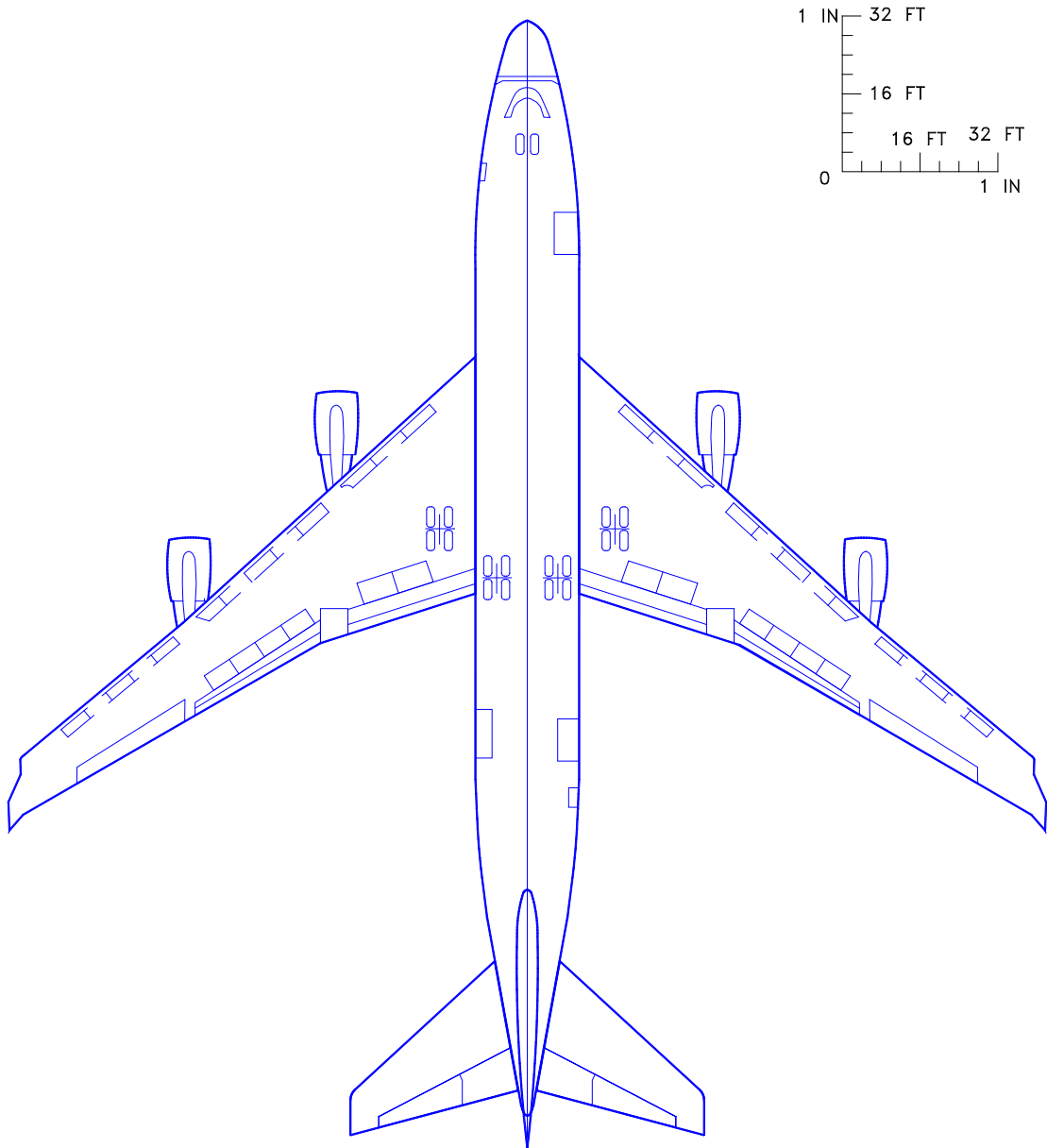

NOTE: ADJUST FOR PROPER SCALING WHEN PRINTING THIS PAGE

9.2.3 Scaled Drawings – 1 IN. = 50 FT: Model 747-400 Freighter, -400ER Freighter

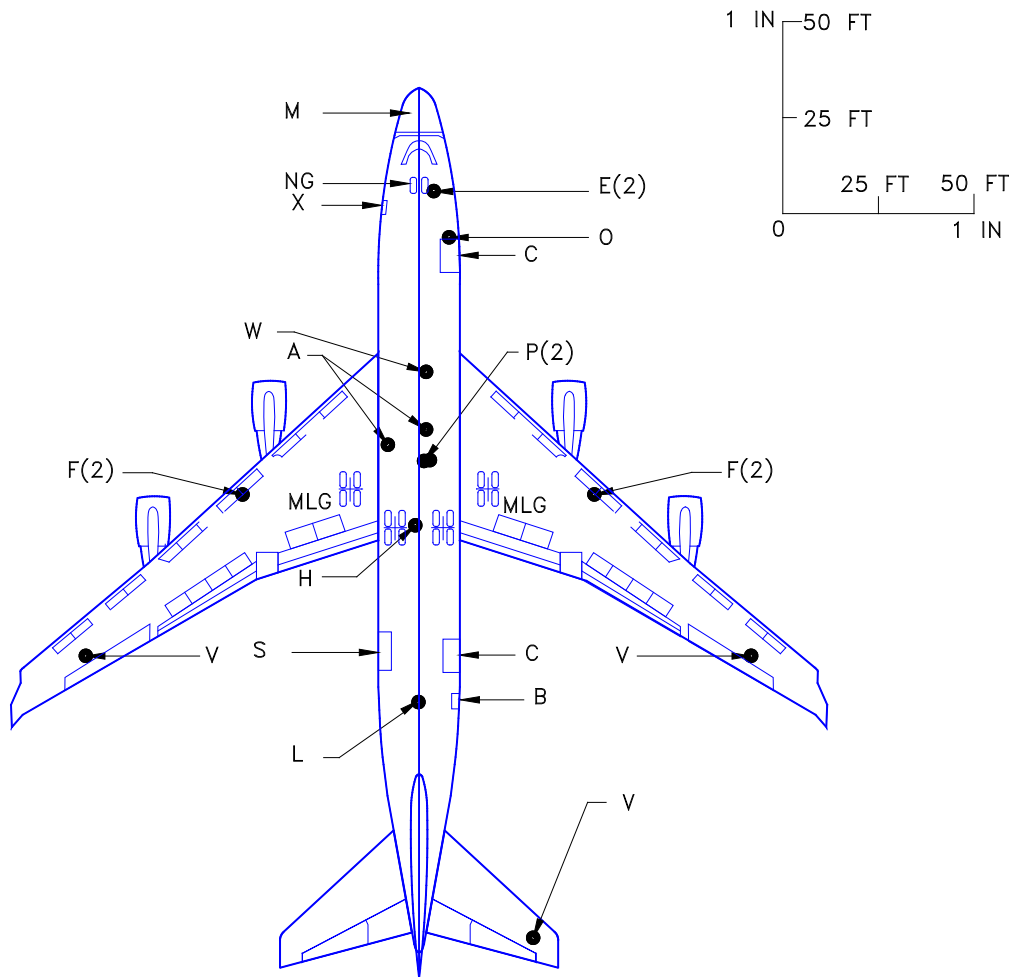

LEGEND

- A AIR CONDITIONING
- B BULK CARGO DOOR
- C CARGO CONTAINER DOOR
- E(2) ELECTRICAL (2 CONNECTIONS)
- F(2) FUEL (2 CONNECTIONS)
- H HYDRAULIC
- L LAVATORY
- M MAIN DECK NOSE CARGO DOOR
- MLG MAIN LANDING GEAR
- NG NOSE GEAR
- O OXYGEN
- P(2) PNEUMATIC (2 CONNECTIONS)
- S MAIN DECK SIDE CARGO DOOR
- U UPPER DECK EXIT DOOR
- V FUEL VENT
- W POTABLE WATER
- X PASSENGER DOOR

NOTE: ADJUST FOR PROPER SCALING WHEN PRINTING THIS PAGE

D6-58326-1

9.2.4 Scaled Drawings – 1 IN. = 50 FT: Model 747-400 Freighter, -400ER Freighter

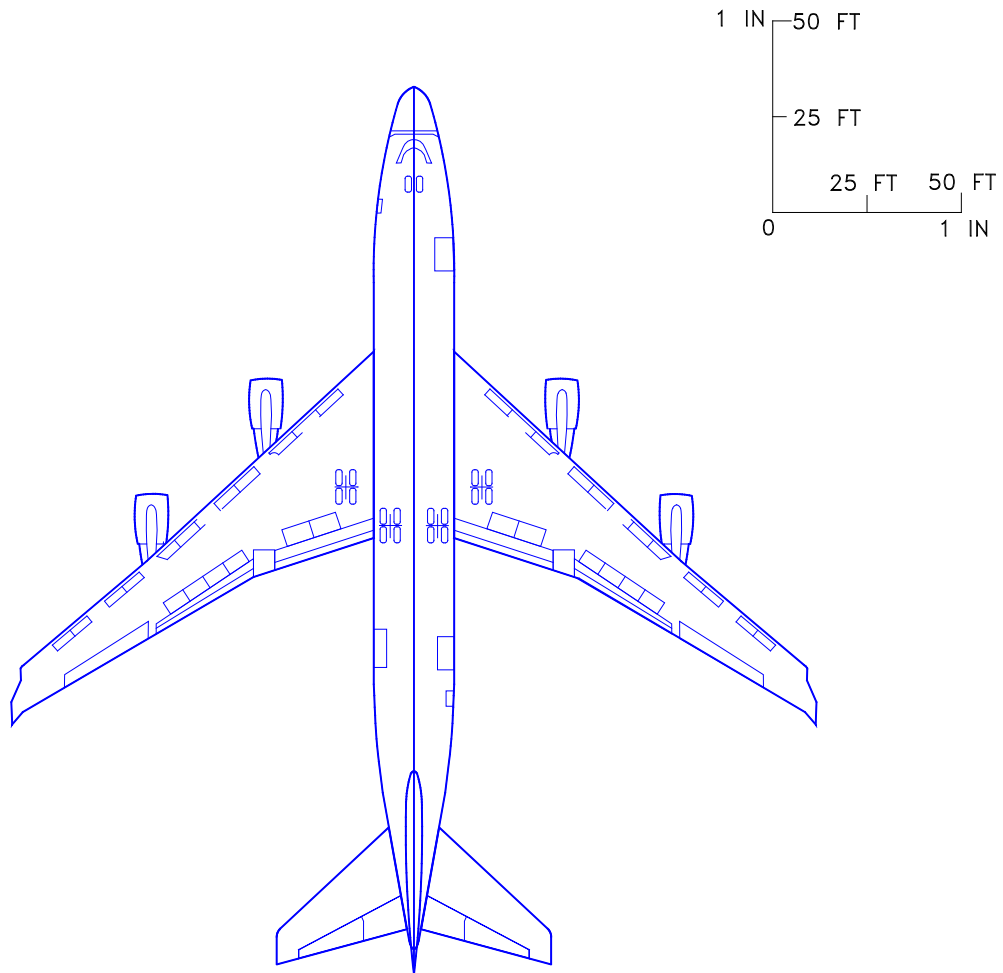

NOTE: ADJUST FOR PROPER SCALING WHEN PRINTING THIS PAGE

9.2.5 Scaled Drawings – 1 IN. = 100 FT: Model 747-400 Freighter, -400ER Freighter

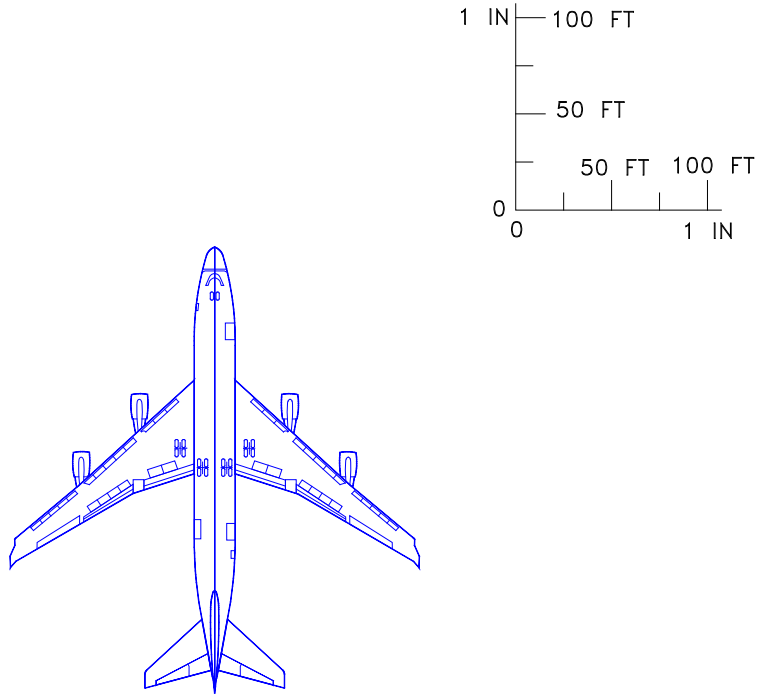

NOTE:
SEE SEC 9.6.1 FOR IDENTIFICATION
OF LEGEND LOCATIONS

LEGEND

- A AIR CONDITIONING
- B BULK CARGO DOOR
- C CARGO CONTAINER DOOR
- E(2) ELECTRICAL (2 CONNECTIONS)
- F(2) FUEL (2 CONNECTIONS)
- H HYDRAULIC
- L LAVATORY
- M MAIN DECK NOSE CARGO DOOR
- MLG MAIN LANDING GEAR
- NG NOSE GEAR
- O OXYGEN
- P(2) PNEUMATIC (2 CONNECTIONS)
- S MAIN DECK SIDE CARGO DOOR
- U UPPER DECK EXIT DOOR
- V FUEL VENT
- W POTABLE WATER
- X PASSENGER DOOR

NOTE: ADJUST FOR PROPER SCALING WHEN PRINTING THIS PAGE

9.2.6 Scaled Drawings – 1 IN. = 100 FT: Model 747-400 Freighter, -400ER Freighter

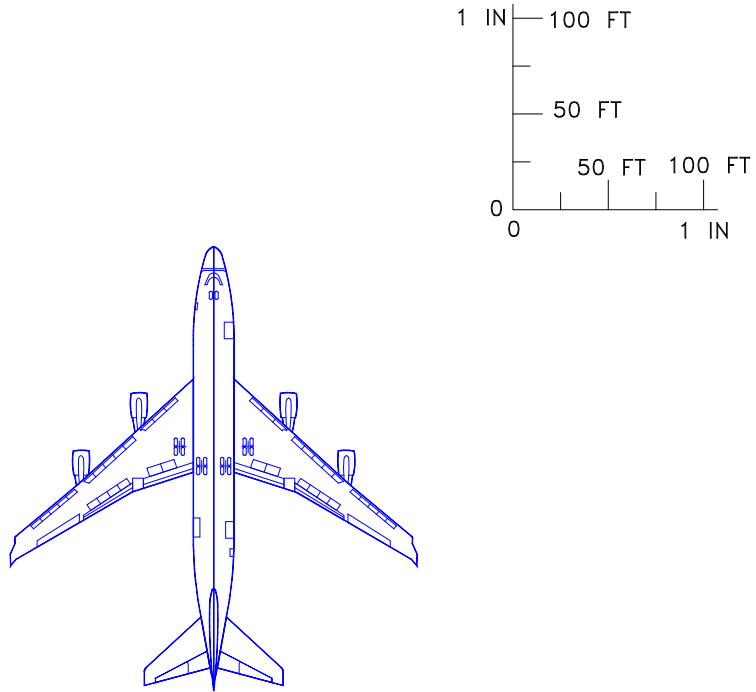

NOTE: ADJUST FOR PROPER SCALING WHEN PRINTING THIS PAGE

9.2.7 Scaled Drawings – 1:500: Model 747-400 Freighter, -400ER Freighter

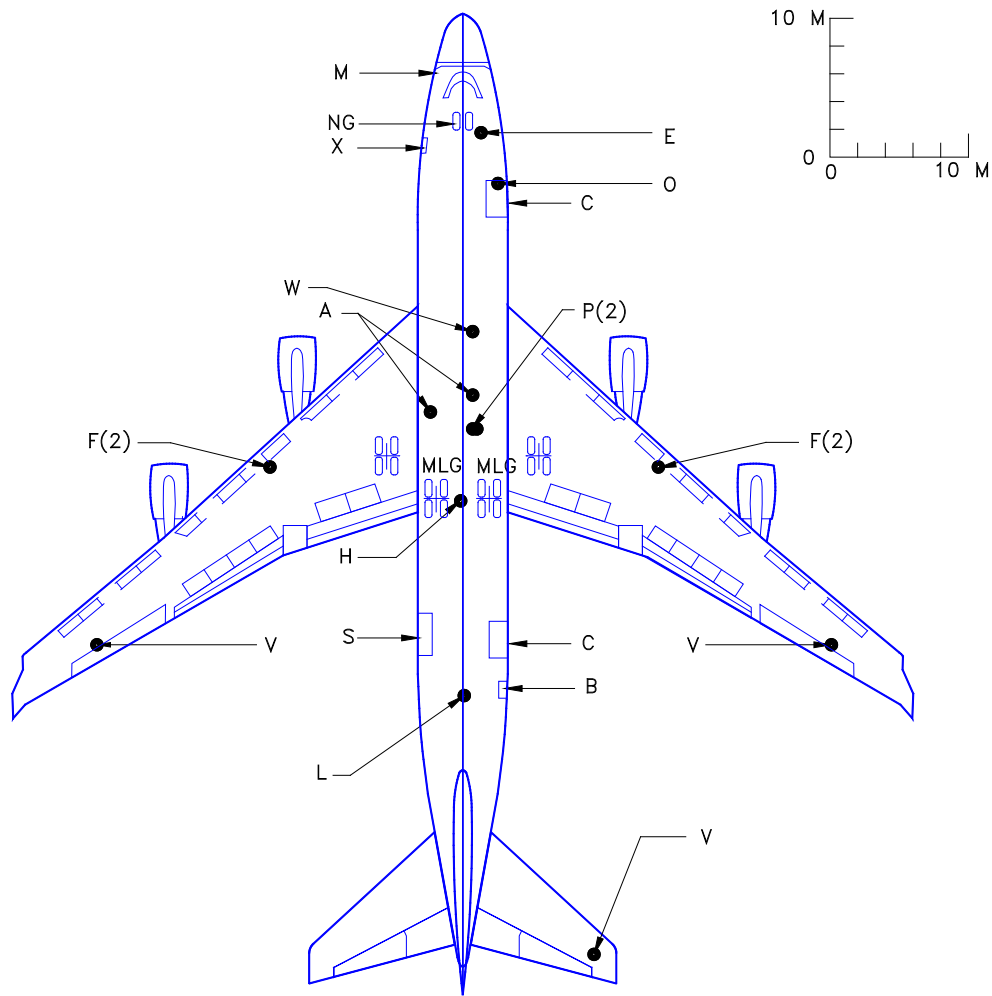

LEGEND

A	AIR CONDITIONING
B	BULK CARGO DOOR
C	CARGO CONTAINER DOOR
E(2)	ELECTRICAL (2 CONNECTIONS)
F(2)	FUEL (2 CONNECTIONS)
H	HYDRAULIC
L	LAVATORY
M	MAIN DECK NOSE CARGO DOOR
MLG	MAIN LANDING GEAR
NG	NOSE GEAR
O	OXYGEN
P(2)	PNEUMATIC (2 CONNECTIONS)
S	MAIN DECK SIDE CARGO DOOR
U	UPPER DECK EXIT DOOR
V	FUEL VENT
W	POTABLE WATER
X	PASSENGER DOOR

NOTE: ADJUST FOR PROPER SCALING WHEN PRINTING THIS PAGE

D6-58326-1

REV E

September 2023

9-18

9.2.8 Scaled Drawings – 1:500: Model 747-400 Freighter, -400ER Freighter

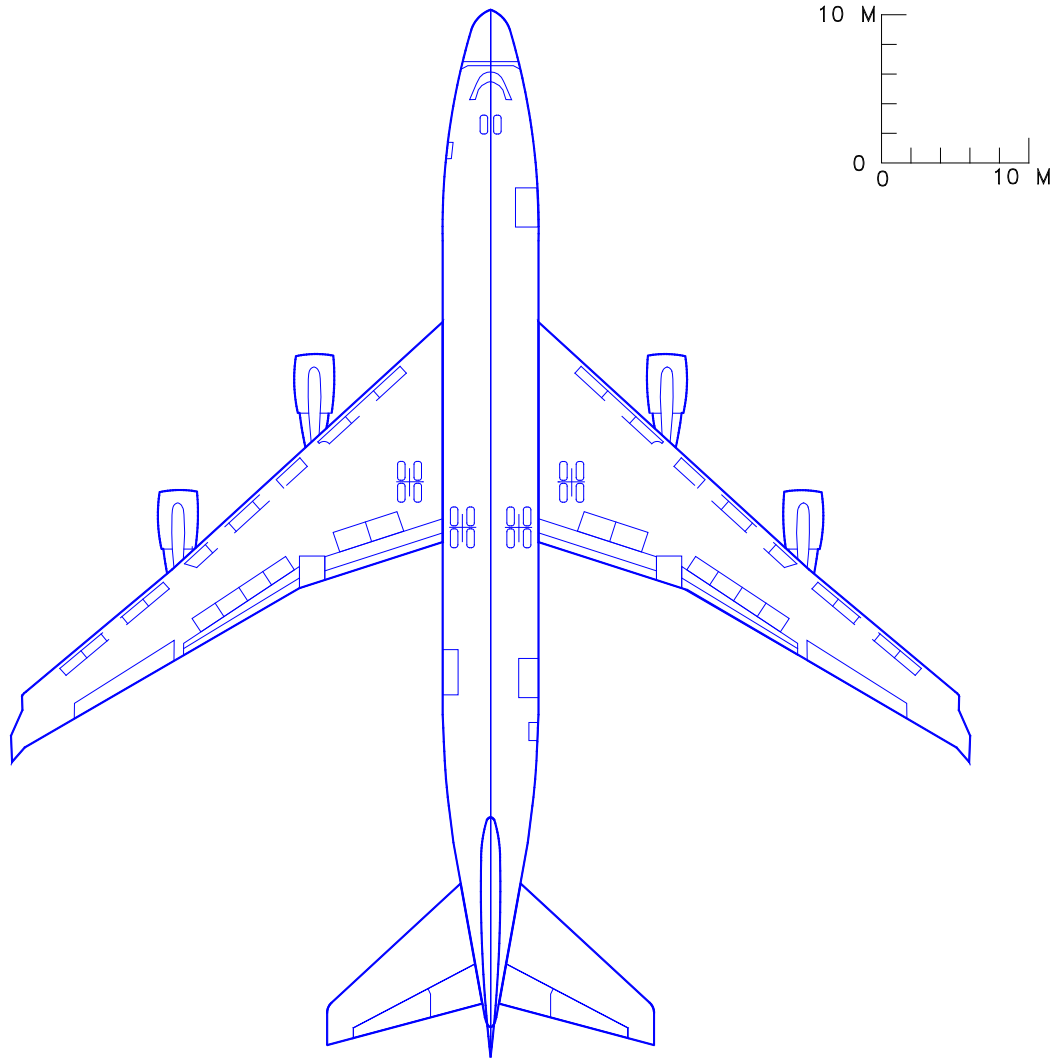

NOTE: ADJUST FOR PROPER SCALING WHEN PRINTING THIS PAGE

9.2.9 Scaled Drawings – 1:1000: Model 747-400 Freighter, -400ER Freighter

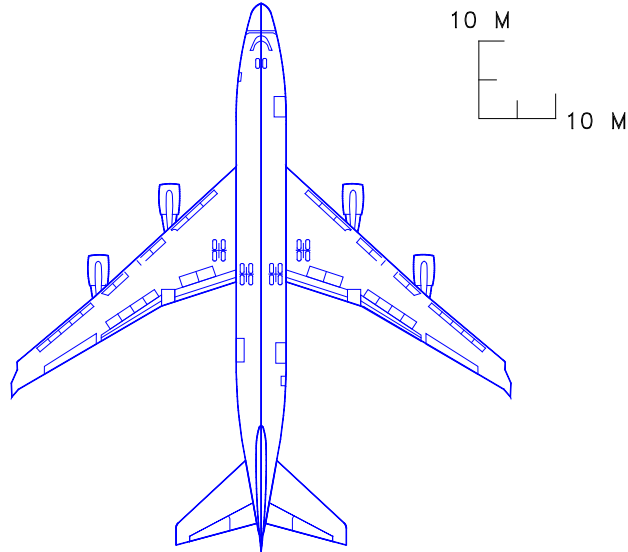

NOTE:
SEE SEC 9.6.1 FOR IDENTIFICATION
OF LEGEND LOCATIONS

LEGEND

- A AIR CONDITIONING
- B BULK CARGO DOOR
- C CARGO CONTAINER DOOR
- E(2) ELECTRICAL (2 CONNECTIONS)
- F(2) FUEL (2 CONNECTIONS)
- H HYDRAULIC
- L LAVATORY
- M MAIN DECK NOSE CARGO DOOR
- MLG MAIN LANDING GEAR
- NG NOSE GEAR
- O OXYGEN
- P(2) PNEUMATIC (2 CONNECTIONS)
- S MAIN DECK SIDE CARGO DOOR
- U UPPER DECK EXIT DOOR
- V FUEL VENT
- W POTABLE WATER
- X PASSENGER DOOR

NOTE: ADJUST FOR PROPER SCALING WHEN PRINTING THIS PAGE

9.2.10 Scaled Drawings – 1:1000: Model 747-400 Freighter, -400ER Freighter

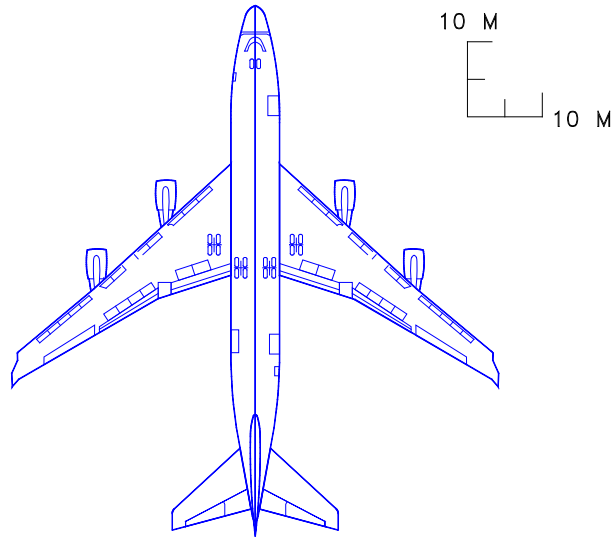

NOTE: ADJUST FOR PROPER SCALING WHEN PRINTING THIS PAGE

9.3 MODEL 747-400 DOMESTIC

9.3.1 Scaled Drawings – 1 IN. = 32 FT: Model 747-400 Domestic

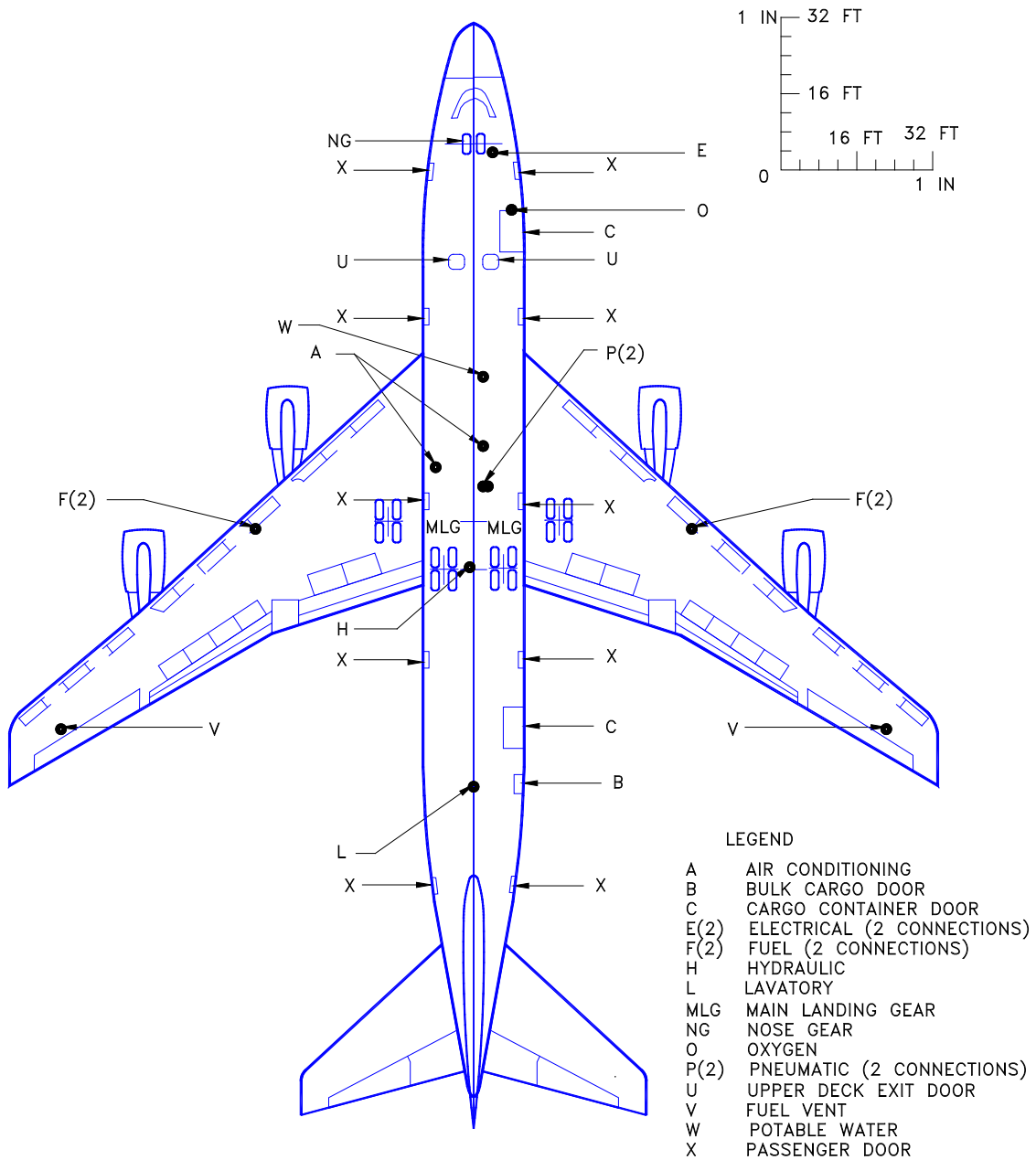

NOTE: ADJUST FOR PROPER SCALING WHEN PRINTING THIS PAGE

9.3.2 Scaled Drawings – 1 IN. = 32 FT: Model 747-400 Domestic

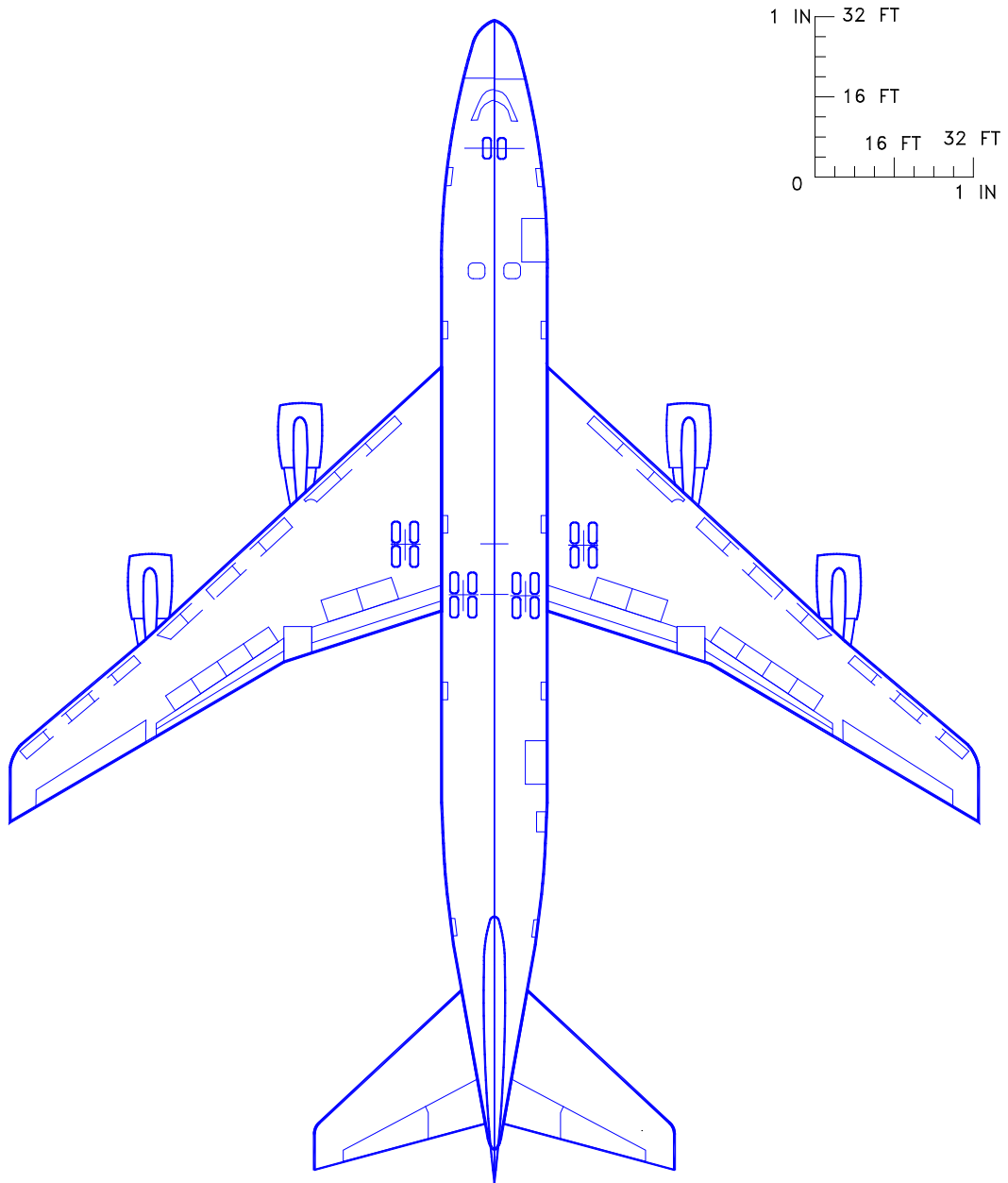

NOTE: ADJUST FOR PROPER SCALING WHEN PRINTING THIS PAGE

9.3.3 Scaled Drawings – 1 IN. = 50 FT: Model 747-400 Domestic

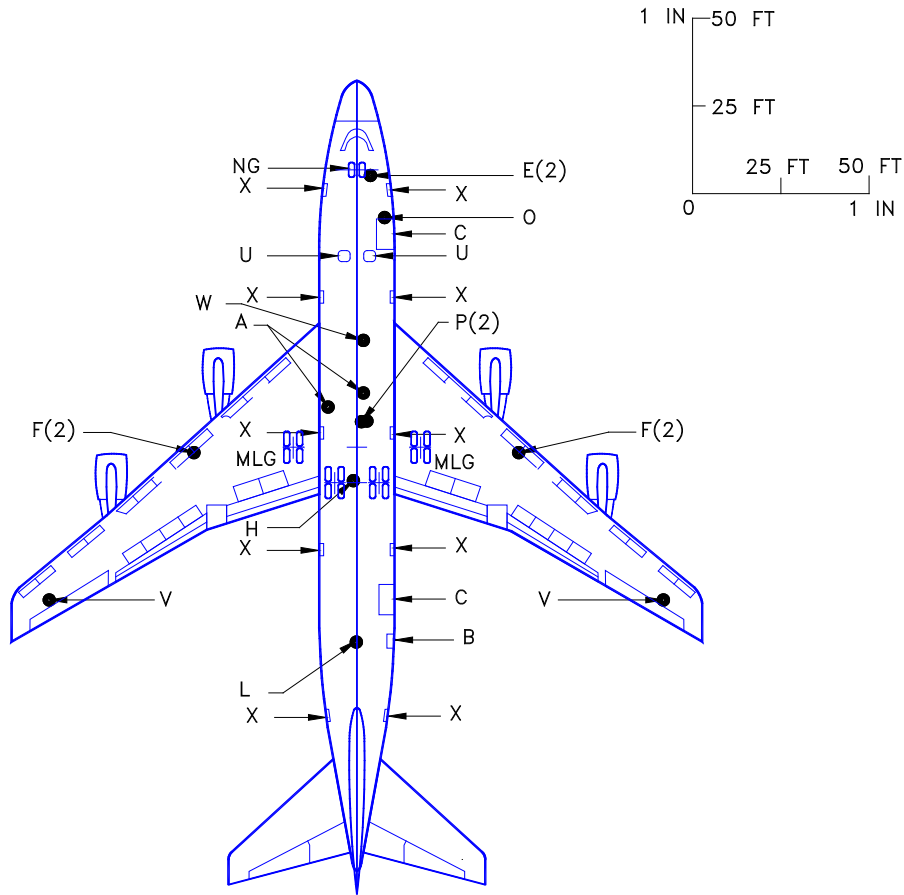

LEGEND

- A AIR CONDITIONING
- B BULK CARGO DOOR
- C CARGO CONTAINER DOOR
- E(2) ELECTRICAL (2 CONNECTIONS)
- F(2) FUEL (2 CONNECTIONS)
- H HYDRAULIC
- L LAVATORY
- MLG MAIN LANDING GEAR
- NG NOSE GEAR
- O OXYGEN
- P(2) PNEUMATIC (2 CONNECTIONS)
- U UPPER DECK EXIT DOOR
- V FUEL VENT
- W POTABLE WATER
- X PASSENGER DOOR

NOTE: ADJUST FOR PROPER SCALING WHEN PRINTING THIS PAGE

D6-58326-1

REV E

September 2023

9-24

9.3.4 Scaled Drawings – 1 IN. = 50 FT: Model 747-400 Domestic

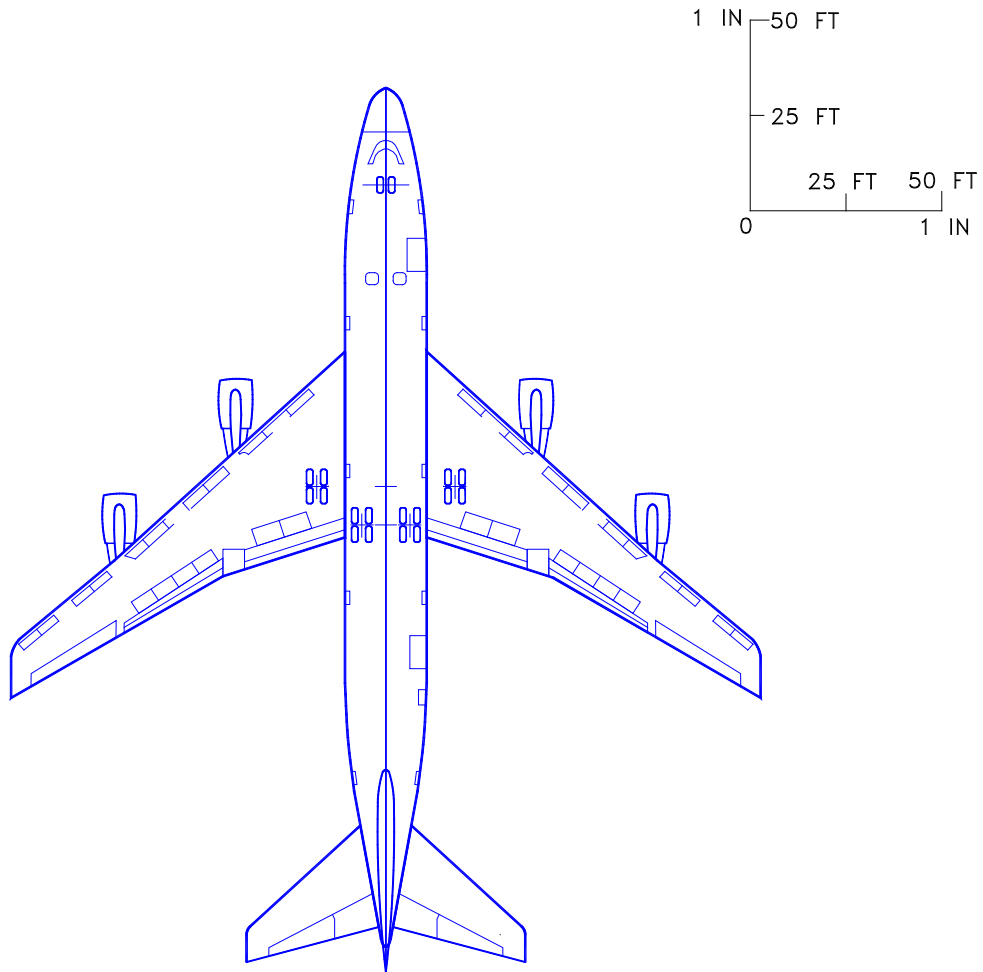

NOTE: ADJUST FOR PROPER SCALING WHEN PRINTING THIS PAGE

9.3.5 Scaled Drawings – 1 IN. = 100 FT: Model 747-400 Domestic

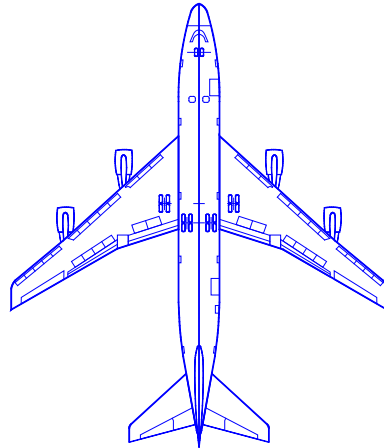
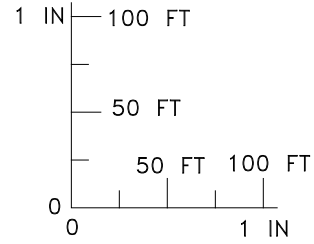

NOTE:
SEE SEC 9.11.1 FOR IDENTIFICATION
OF LEGEND LOCATIONS

LEGEND

- A AIR CONDITIONING
- B BULK CARGO DOOR
- C CARGO CONTAINER DOOR
- E(2) ELECTRICAL (2 CONNECTIONS)
- F(2) FUEL (2 CONNECTIONS)
- H HYDRAULIC
- L LAVATORY
- MLG MAIN LANDING GEAR
- NG NOSE GEAR
- O OXYGEN
- P(2) PNEUMATIC (2 CONNECTIONS)
- U UPPER DECK EXIT DOOR
- V FUEL VENT
- W POTABLE WATER
- X PASSENGER DOOR

NOTE: ADJUST FOR PROPER SCALING WHEN PRINTING THIS PAGE

9.3.6 Scaled Drawings – 1 IN. = 100 FT: Model 747-400 Domestic

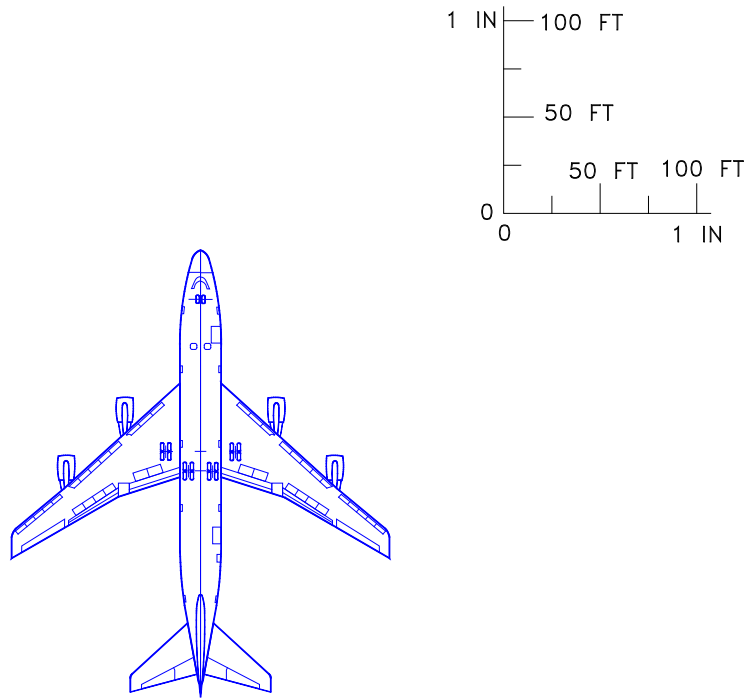

NOTE: ADJUST FOR PROPER SCALING WHEN PRINTING THIS PAGE

9.3.7 Scaled Drawings – 1:500: Model 747-400 Domestic

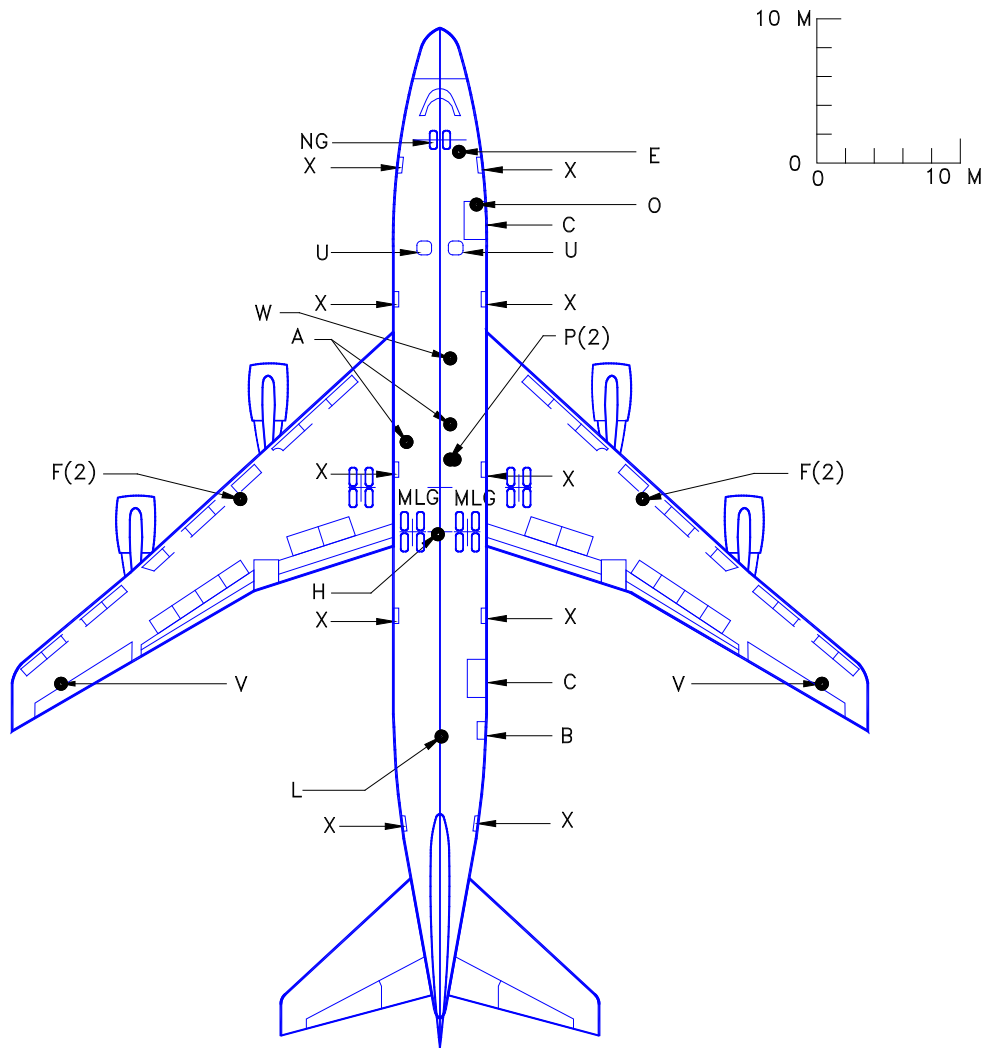

LEGEND

- A AIR CONDITIONING
- B BULK CARGO DOOR
- C CARGO CONTAINER DOOR
- E(2) ELECTRICAL (2 CONNECTIONS)
- F(2) FUEL (2 CONNECTIONS)
- H HYDRAULIC
- L LAVATORY
- MLG MAIN LANDING GEAR
- NG NOSE GEAR
- O OXYGEN
- P(2) PNEUMATIC (2 CONNECTIONS)
- U UPPER DECK EXIT DOOR
- V FUEL VENT
- W POTABLE WATER
- X PASSENGER DOOR

NOTE: ADJUST FOR PROPER SCALING WHEN PRINTING THIS PAGE

9.3.8 Scaled Drawings – 1:500: Model 747-400 Domestic

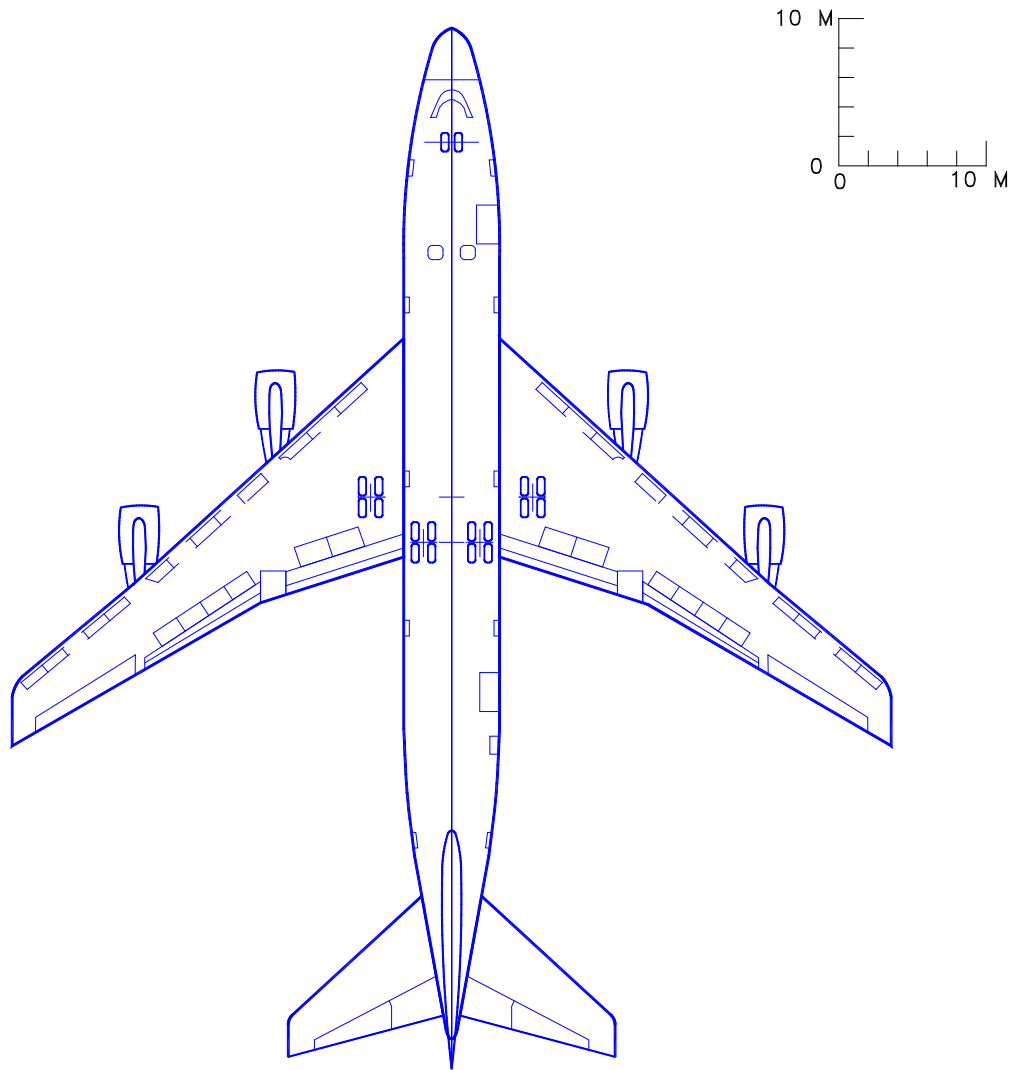

NOTE: ADJUST FOR PROPER SCALING WHEN PRINTING THIS PAGE

9.3.9 Scaled Drawings – 1:1000: Model 747-400 Domestic

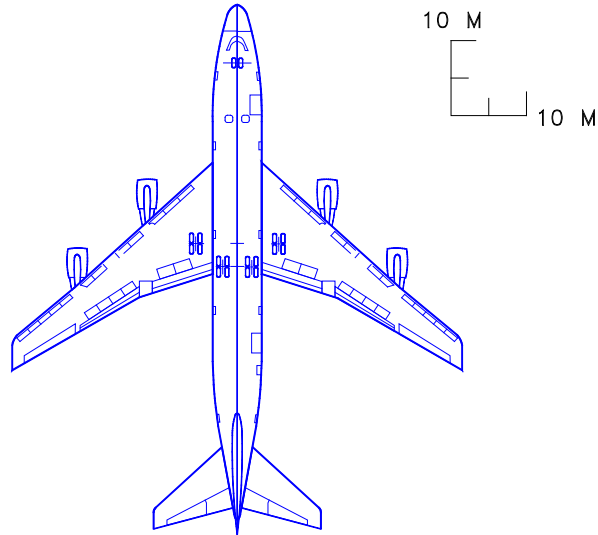

NOTE:
SEE SEC 9.11.1 FOR IDENTIFICATION
OF LEGEND LOCATIONS

LEGEND

A	AIR CONDITIONING
B	BULK CARGO DOOR
C	CARGO CONTAINER DOOR
E(2)	ELECTRICAL (2 CONNECTIONS)
F(2)	FUEL (2 CONNECTIONS)
H	HYDRAULIC
L	LAVATORY
MLG	MAIN LANDING GEAR
NG	NOSE GEAR
O	OXYGEN
P(2)	PNEUMATIC (2 CONNECTIONS)
U	UPPER DECK EXIT DOOR
V	FUEL VENT
W	POTABLE WATER
X	PASSENGER DOOR

NOTE: ADJUST FOR PROPER SCALING WHEN PRINTING THIS PAGE

9.3.10 Scaled Drawings – 1:1000: Model 747-400 Domestic

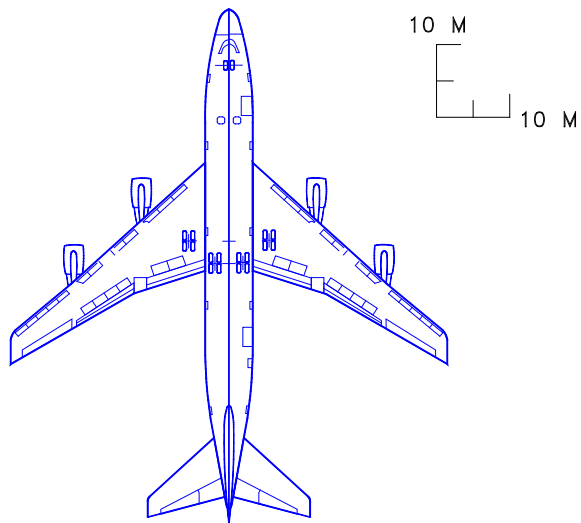

NOTE: ADJUST FOR PROPER SCALING WHEN PRINTING THIS PAGE